

# ALUMINIUM ENCLOSED CONDUCTOR SYSTEMS

LSV and LSVG



# ALUMINIUM ENCLOSED CONDUCTOR SYSTEMS

## INDEX

	Page		Page
Powerail versions (Photos)	2	Transfer Guides, oblique cut	15
Technical Data	2	Heating System	16
Basic Description	3	Anti-condensation Sections	17
Powerail Cat.-Nos. and Weights	4	Telescope Sections	18
Engineering Data and Configurations	5	Expansion Joint Sections	19
Standard Sections & Curves	6	Collectors	20
Joint Material	7	Double Collectors	21
Brackets	8	Tow Arms	22
Hangers	9	Flexible Tow Arm Configurations	23
End Caps	10	Sectionalizing	24
End Feeds	10	Spare Parts	24
Line Feeds	11	Application Photos	25, 27
Transfer and switch Arrangements	12	Examples for ordering	26, 27
Transfer Funnels	13	Basic Dimensions	28
Transfer Guides, straight cut	14	Questionnaire	29, 30



Type LSV



Type LSVG



Type LSV with Plastic shielding "FP"

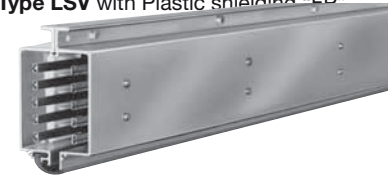

Type LSVG with sealing strip "D"

## Technical Data

Ampacity :300 A max.  
 Voltage :600 V max.  
 Collector rating : 40 A up to 80 A  
 min. Bending Radius: LSV 750 mm/ LSVG 1500 mm

Impedance:	16	25	35	50	70	mm <sup>2</sup> copper
	1.17	0.72	0.53	0.38	0.28	Ohm/1000 m

## Temperature Resistance:

Powerail - 40° C/+100° C  
 Sealing strip "D" up to + 80° C  
 Plastic shielding "FP" up to +55° C  
 Collector - 40° C/+ 70° C<sup>(1)</sup>

Resistance:	16	25	35	50	70	mm <sup>2</sup> copper
	1.16	0.71	0.51	0.36	0.26	Ohm/1000 m

## Consider the voltage drop calculation to maintain the limits established by the motor manufacturers:

### Formulas:

AC:

$$\Delta U = \sqrt{3} \times I \times l \times Z$$

DC:

$$\Delta U_1 = 2I \times l \times R$$

$$\Delta U_2 = \frac{\Delta U_1 \cdot 100}{V}$$

$\Delta U_1$  = Voltage drop [V]  
 $\Delta U_2$  = Voltage drop in %  
 I = Ampere load [A]

V = System Voltage  
 l = Power feed length [m]  
 L = System length [m]

### Effective length:

l = L power feed located at the end of the system  
 l = L/2 power feed located at the mid-point of the system  
 l = L/4 power feed located at both ends of the system  
 l = L/6 power feed located at L/6 from each end of the system

Z= Impedance in Ohm/1000 m  
 R= Resistance in Ohm/1000 m

The total ampere load is determined from the nominal rated current of all motors working simultaneously on the same feed section of your electrification system.

The number of feed points should be increased in case the drop is exceeding the limitations – or it may be necessary to provide booster cables.



## General

The Vahle Aluminium enclosed Powerails LSV and LSVG are compact and safe prefabricated Electrification Systems.

These systems are ideal for indoor and outdoor use, for all types of installations requiring a moving or movable source of electrical power: cranes, monorails, hoists, electric power tools, machine tools, storage and retrieval systems and many other mobile machinery applications. LSV and LSVG are especially well suited for higher ambient temperatures.

The principal advantages of these systems are maximum electrical and personnel safety, compactness, dependability and minimal maintenance expense. They fully meet all safety requirements; VDE 0470 § 3; Protection IP 23, with sealing strip IP 24 per EN 60529 applies.

In special cases the plastic shielding FP provides additional safety. For the collectors applies protection against contact only if the brushes are complete in the conductor rail.

Conductor rails in the hand area in which the collectors leave the powerail under normal service conditions, must have a protection against contact on site e.g. through barriers or disconnection. This is only necessary at voltages above 25 V AC or 60 V DC. Different cross section combinations, as shown on page 4 are possible. Please consider VDE 0100 part 430 in case of using a N-pole.

The aluminium enclosed LSV 4- and 5pole and the PVC enclosed KSL 4- and 5pole (see cat. 4a) can be combined by means of a transfer piece.

## Housing

The system consists of two prefabricated, standardized aluminium profiles which are bolted together. The polarizing long and short lip profiles prevent accidental reversal and avoid phase reversing of collectors (see pages 5 & 6). The lateral arrangement of insulators and copper conductors allows 4-7 conductors in the LSV and 6-11 conductors in the LSVG housing.

The 5, 7, 9 and 11 pole systems use an uninsulated ground conductor (see page 5).

Curved track sections to contour to almost any job requirement can be furnished to order.

We do recommend the anodized version for installations in coastal areas, river valleys or other humid and aggressive environments. Heating systems for icing conditions are available.

All LSV and LSVG housings can be equipped with a Neoprene sealing strip or a Plastic shielding as shown on page 6 of this catalog. Standard duct sections are 1, 2, 3 or 4 m long; other sections to coincide with your runway requirements are available.

End caps close the open Powerail ends.

## Couplings

The 60, 100 and 140 Amp. systems use side fish plates for joining adjacent sections; the 200 and 300 Amp. Sizes and all bolted conductor joint versions have joint covers (see installation information).

The lower portion of the housing serves as a smooth, rigid runway for the collector trolleys and is aligned by grooved push pegs.

Conductor rails on the 60, 100 and 140 Amp. sizes are spliced by connectors being pushed inside the hollow conductors. Bolted joints are also available for these sizes.

The 200 and 300 Amp. systems exclusively use bolted joints (see mounting information).

## Feed Sets

End feeds or line feeds are available.

End feed boxes 4-11 pole are designed for max. 60 Amperes; line feed boxes rate from 60 to 300 Amperes. Space-saving line feeds with 2 m connection cables are available.

The factory assembled 1 m feed-in tracks integrate in your system length.

## Brackets & Hangers

We do recommend to use our standard supporting brackets, page 8 for monorail and hoist applications.

Standard support spacing is 2 m. Up to 3 m support spacing is possible when using joint covers for connecting the duct sections. Use one fix point hanger; all others are sliding hangers (see installation instructions).

## Expansion Joint Sections

These expansion joints can compensate for expansion and contraction difference between aluminium housing and copper conductors. They do not interrupt electric current flow.

## Telescope & Anti-condensation sections

The telescope devices serve for length-compensation in high temperature fluctuations, for runs exceeding 200 m. For combined indoor/outdoor applications use the anti-condensation section. A separate feeding on both sides of these units is required.

## Contact Sections, Turntables, Switches

Powerails for working areas and transfer applications see page 12.

## Sectionalizing

Conductor dead sections are electrical interrupts of the conductor. Under normal operating conditions a cross over with collectors to switch the voltage off or on is only allowed with low power ratings (control current).

Available as air gap version (5 mm), where the collector carbon bridges the gap, e. g. for mains.

Also available as insulating piece version (35 mm). In this case the insulating piece is longer than the carbon and each Powerail section can be separated electrically, e.g. for control.

## Collectors

The collectors are made of impact resistant pvc.

The power will be transferred through spring supported brushes. The connection takes place through connecting cables or connection boxes. The mechanical connection to the consumer are provided by towing arms. For cross travel in switches or turntables and higher electrical load double collectors are necessary. The length of the connecting cable should not exceed 3 m, if the fuse is not laid out for this rating. See DIN VDE 0100, part 430 and DIN EN 60204-32. (Note: A.m. appears often in systems with more than one collector.) The provided connecting cables are sufficient for the quoted nominal current. For the different layout systems have the reduction factor according to DIN VDE 0298-4 be considered.

## Safety notice

Please ensure that the arrangement of the collectors (conductor rail) and collector arms made by the customer is according to the safety distance of min. 0.5 m to prevent the danger of crushing.

### Note:

**In case of use in galvanising plants, pickle shops, aggressive environments, installations in firedamp areas or underneath a drainage area and if low voltage is required we recommend to send us your enquiry with full details (see questionnaire on page 29/30).**

**For the preparation of quotes and orders we require drawings if the conductor has curves, dead sections, turntables or switches.**



# TYPES, ENGINEERING DATA AND CATALOG NUMBERS

## LSV

Type	HS w/ PE SS w/o PE	No. of Poles	Ampacity at 80 % ED L1, L2, L3 A	No. of conductors x copper section mm <sup>2</sup>			
				L1, L2, L3	⊕ <sup>(2)</sup>	N	Control-Line
LSV 4/ 60 HS		4	60	3 x 16	1 x 16	–	–
LSV 4/ 60 SS	Control line	4	60	–	–	–	4 x 16
LSV 4/100 HS		4	100	3 x 25	1 x 16	–	–
LSV 4/140 HS		4	140	3 x 35	1 x 16	–	–
LSV 4/200 HS <sup>(1)</sup>		4	200	3 x 50	1 x 25	–	–
LSV 4/300 HS <sup>(1)</sup>		4	300	3 x 70	1 x 50	–	–
LSV 5/ 60 HS		5	60	3 x 16	1 x 16	1 x 16	–
LSV 5/100 HS		5	100	3 x 25	1 x 16	1 x 25	–
LSV 5/140 HS		5	140	3 x 35	1 x 16	1 x 35	–
LSV 5/200 HS <sup>(1)</sup>		5	200	3 x 50	1 x 16	1 x 50	–
LSV 5/300 HS <sup>(1)</sup>		5	300	3 x 70	1 x 16	1 x 70	–
LSV 6/ 60 HS		6	60	3 x 16	1 x 16	–	2 x 16
LSV 6/ 60 SS	Control line	6	60	–	–	–	6 x 16
LSV 6/100 HS		6	100	3 x 25	1 x 16	–	2 x 16
LSV 6/140 HS		6	140	3 x 35	1 x 16	–	2 x 16
LSV 6/200 HS <sup>(1)</sup>		6	200	3 x 50	1 x 25	–	2 x 16
LSV 7/ 60 HS		7	60	3 x 16	1 x 16	1 x 16	2 x 16
LSV 7/100 HS		7	100	3 x 25	1 x 16	1 x 25	2 x 16
LSV 7/140 HS		7	140	3 x 35	1 x 16	1 x 35	2 x 16
LSV 7/200 HS <sup>(1)</sup>		7	200	3 x 50	1 x 16	1 x 50	2 x 16

## LSVG

LSVG 6/ 60 HS		6	60	3 x 16	1 x 16	–	2 x 16
LSVG 6/ 60 SS	Control line	6	60	–	–	–	6 x 16
LSVG 6/100 HS		6	100	3 x 25	1 x 16	–	2 x 16
LSVG 6/140 HS		6	140	3 x 35	1 x 16	–	2 x 16
LSVG 6/200 HS <sup>(1)</sup>		6	200	3 x 50	1 x 25	–	2 x 16
LSVG 6/300 HS <sup>(1)</sup>		6	300	3 x 70	1 x 50	–	2 x 20
LSVG 7/ 60 HS		7	60	3 x 16	1 x 16	1 x 16	2 x 16
LSVG 7/100 HS		7	100	3 x 25	1 x 16	1 x 25	2 x 16
LSVG 7/140 HS		7	140	3 x 35	1 x 16	1 x 35	2 x 16
LSVG 7/200 HS <sup>(1)</sup>		7	200	3 x 50	1 x 16	1 x 50	2 x 16
LSVG 7/300 HS <sup>(1)</sup>		7	300	3 x 70	1 x 16	1 x 70	2 x 20
LSVG 8/ 60 HS		8	60	3 x 16	1 x 16	–	4 x 16
LSVG 8/ 60 SS	Control line	8	60	–	–	–	8 x 16
LSVG 8/100 HS		8	100	3 x 25	1 x 16	–	4 x 16
LSVG 8/140 HS		8	140	3 x 35	1 x 16	–	4 x 16
LSVG 8/200 HS <sup>(1)</sup>		8	200	3 x 50	1 x 25	–	4 x 16
LSVG 9/ 60 HS		9	60	3 x 16	1 x 16	1 x 16	4 x 16
LSVG 9/100 HS		9	100	3 x 25	1 x 16	1 x 25	4 x 16
LSVG 9/140 HS		9	140	3 x 35	1 x 16	1 x 35	4 x 16
LSVG 9/200 HS <sup>(1)</sup>		9	200	3 x 50	1 x 16	1 x 50	4 x 16
LSVG 10/ 60 HS		10	60	3 x 16	1 x 16	–	6 x 16
LSVG 10/ 60 SS	Control line	10	60	–	–	–	10 x 16
LSVG 10/100 HS		10	100	3 x 25	1 x 16	–	6 x 16
LSVG 10/140 HS		10	140	3 x 35	1 x 16	–	6 x 16
LSVG 10/200 HS <sup>(1)</sup>		10	200	3 x 50	1 x 25	–	6 x 16
LSVG 11/ 60 HS		11	60	3 x 16	1 x 16	1 x 16	6 x 16
LSVG 11/100 HS		11	100	3 x 25	1 x 16	1 x 25	6 x 16
LSVG 11/140 HS		11	140	3 x 35	1 x 16	1 x 35	6 x 16
LSVG 11/200 HS <sup>(1)</sup>		11	200	3 x 50	1 x 16	1 x 50	6 x 16

4

<sup>(1)</sup> With bolted joints only other types can be delivered with bolted joints without surcharge (on request).

<sup>(2)</sup> The ground conductor ⊕ = PE is always connected to the Powerail housing and marked accordingly. The ground bar is uninsulated in the case of 5-, 7-, 9- and 11pole systems. Mounting configurations see pages 8, 11, 23, 28.

max. Voltage V	Leakage Path mm	Weight kg/m	Order- No.	Configurations
600	45	3,000	190 00 •	<p>LSV 4pole, 60-300 A</p> <p>LSV 5pole, 60-300 A</p> <p>LSV 6pole, 60-200 A</p> <p>LSV 7pole, 60-200 A</p>
600	45	3,000	190 10 •	
600	45	3,400	190 04 •	
600	45	3,700	190 08 •	
600	45	4,300	190 61 •	
600	35	5,000	190 60 •	
600	45	3,150	190 01 •	
600	45	3,550	190 03 •	
600	45	3,850	190 05 •	
600	45	4,450	190 62 •	
600	35	5,150	190 63 •	
600	45	3,300	190 02 •	
600	45	3,300	190 11 •	
600	45	3,700	190 06 •	
600	45	4,000	190 64 •	
600	45	4,480	195 52 •	
600	45	3,450	190 07 •	
600	45	3,850	190 09 •	
600	45	4,250	190 65 •	
600	45	4,730	195 60 •	

600	45	5,150	180 00 •	<p>LSVG 6pole, 60-300 A</p> <p>LSVG 7pole, 60-300 A</p> <p>LSVG 8pole, 60-300 A</p> <p>LSVG 9pole, 60-300 A</p> <p>LSVG 10pole, 60-300 A</p> <p>LSVG 11pole, 60-300 A</p>
600	45	5,150	180 22 •	
600	45	5,450	180 01 •	
600	45	5,750	180 02 •	
600	45	6,300	180 03 •	
600	35	7,250	180 04 •	
600	45	5,300	180 05 •	
600	45	5,700	180 06 •	
600	45	6,100	180 07 •	
600	45	6,700	180 08 •	
600	35	7,400	180 09 •	
600	45	5,450	180 10 •	
600	45	5,450	180 23 •	
600	45	5,750	180 11 •	
600	45	6,050	180 12 •	
600	45	6,530	184 58 •	
600	45	5,600	180 13 •	
600	45	6,000	180 14 •	
600	45	6,400	180 15 •	
600	45	6,940	184 59 •	
600	45	5,750	180 16 •	
600	45	5,750	180 24 •	
600	45	6,050	180 17 •	
600	45	6,350	180 18 •	
600	45	6,830	184 60 •	
600	45	5,900	180 19 •	
600	45	6,300	180 20 •	
600	45	6,700	180 21 •	
600	45	7,240	184 61 •	

• Add last number (1, 2, 3, 4 m length suffix) in accordance to bars required.

Numbers in parenthesis are used for control circuit applications.



## STANDARD SECTION MAX. 4 M

## CURVED SECTION

LSV

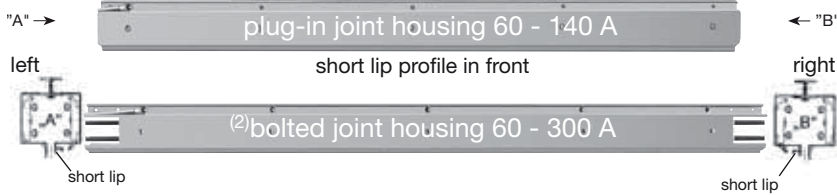

Extra finish of LSV; surcharge Order- No.

Type	Index E anodized housing Order- No.	Index I copper conductors with stainless steel cap	
		Order- No. 60 A	Order- No. 200 A
LSV 4pole	190 660	194 754	194 755
LSV 5pole	190 670	194 756	194 757
LSV 6pole	190 660	194 758	-
LSV 7pole	190 670	194 760	-

Supplements for LSV:

Illustration see page 2	Type	Weight kg/m	Order- No.
Neoprene sealing strip	<b>D</b>	0,225	254 751
Fastener for sealing strip (pair)			258 432
Coupling for sealing strip for length exceeding 50 m			258 300
Mounting trolley for sealing strip			258 345
Plastic shielding <sup>(1)</sup> incl. locking pin for plastic shielding	<b>FP</b>	0,260	196 574

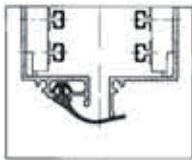

Neoprene sealing strip

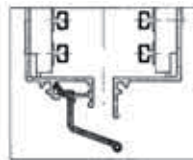

Plastic shielding

Custom built

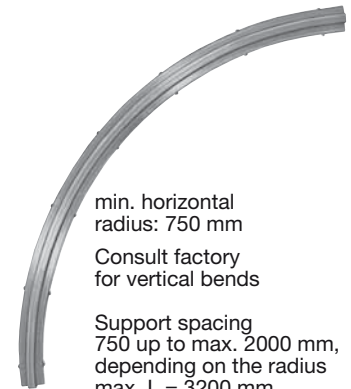

min. horizontal radius: 750 mm

Consult factory for vertical bends

Support spacing 750 up to max. 2000 mm, depending on the radius max. L = 3200 mm, max.  $\alpha = 120^\circ$

surcharge	Order- No.
horizontal curve L max. 1.8 m	194 420
horizontal curve L from 1.8 m to max. 3.2 m	195 285

Long lip side of Powerail should always be mounted towards the track (see page 28). Notify exceptions for replacements and/or extensions and determine correct curves.

LSVG

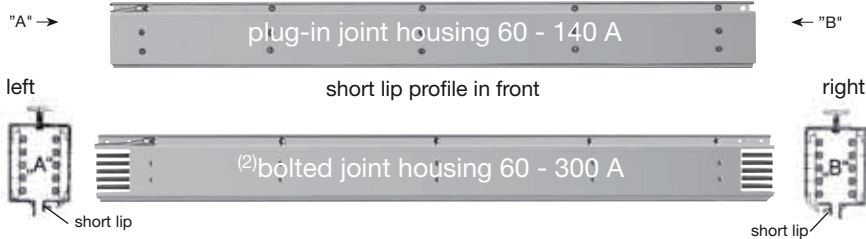

Extra finish of LSVG; surcharge Order- No.

Type	Index E anodized housing Order- No.	Index I copper conductors with stainless steel cap	
		Order- No. 60 A	Order- No. 200 A
LSVG 6pole	180 250	183 871	183 872
LSVG 7pole	180 260	183 873	183 874
LSVG 8pole	180 250	183 875	-
LSVG 9pole	180 260	183 877	-
LSVG 10pole	180 250	183 879	-
LSVG 11pole	180 260	183 881	-

Supplements for LSVG:

Illustration see page 2	Type	Weight kg/m	Order- No.
Neoprene sealing strip	<b>D</b>	0,225	254 751
Fastener for sealing strip (pair)			258 432
Coupling for sealing strip for length exceeding 50 m			258 300
Mounting trolley for sealing strip			184 033
Plastic shielding <sup>(1)</sup> incl. locking pin for plastic shielding	<b>FP</b>	0,260	196 574

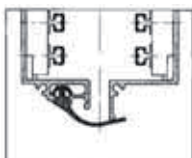

Neoprene sealing strip

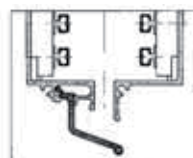

Plastic shielding

Custom built

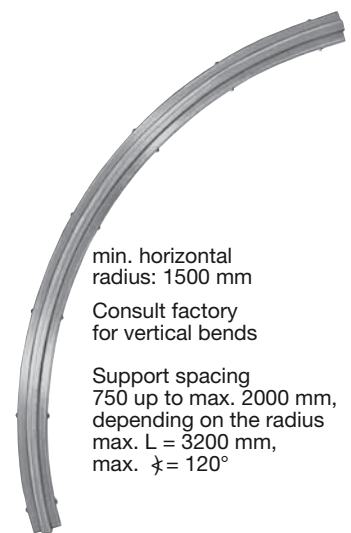

min. horizontal radius: 1500 mm

Consult factory for vertical bends

Support spacing 750 up to max. 2000 mm, depending on the radius max. L = 3200 mm, max.  $\alpha = 120^\circ$

surcharge	Order- No.
horizontal curve L max. 1.8 m	183 810
horizontal curve L from 1.8 m to max. 3.2 m	184 170

Long lip side of Powerail should always be mounted towards the track (see page 28). Notify exceptions for replacements and/or extensions and determine correct curves.

<sup>(1)</sup> Plastic shielding FP not for curves.

<sup>(2)</sup> All other types are to be delivered with bolted joints w/o surcharge.

### Plug-in joints 60-140 A

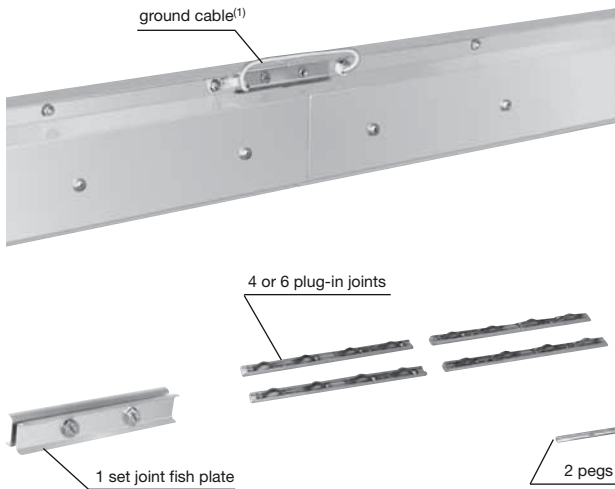

Type		Weight kg	Order- No.
<b>VBL 4/5</b>	for 4- and 5-pole	0,110	195 244
<b>VBL 6/7</b>	for 6- and 7-pole	0,140	195 246

### Bolted joints 60-300 A

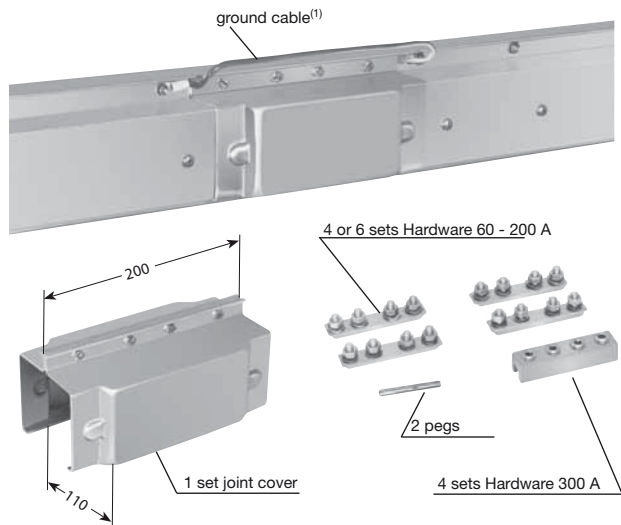

Type		Weight kg	Order- No.	Order- No. anodized
<b>VBLS 4/5</b>	for 4- and 5-pole	0,450	195 248	-
<b>VBLS/E 4/5</b>	60-200 Amp.	0,450	-	195 255
<b>VBLS 6/7</b>	for 6- and 7-pole	0,505	195 250	-
<b>VBLS/E 6/7</b>	60-200 Amp.	0,505	-	195 259
<b>VBLSG 4/5</b>	for 4- and 5-pole	0,605	195 252	-
<b>VBLSG/E 4/5</b>	300 Amp.	0,605	-	195 256

### Plug-in joints 60-140 A

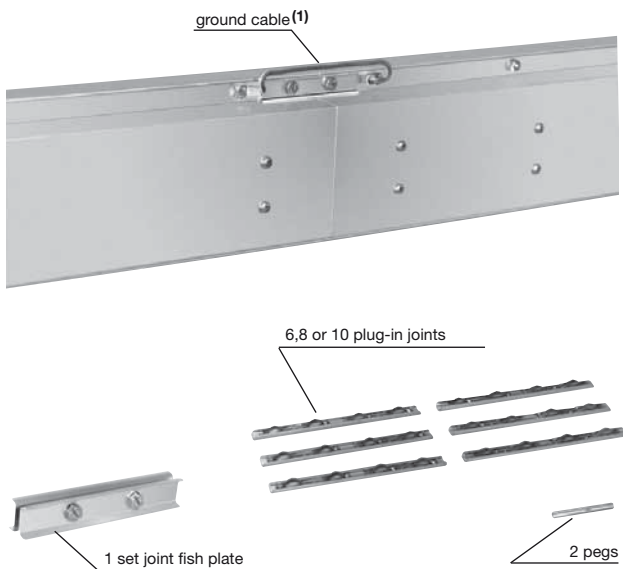

Type		Weight kg	Order- No.
<b>VLG 6/7</b>	for 6- and 7-pole	0,135	184 107
<b>VLG 8/9</b>	for 8- and 9-pole	0,165	184 109
<b>VLG 10/11</b>	for 10- and 11-pole	0,195	184 111

### Bolted joints 60-300 A

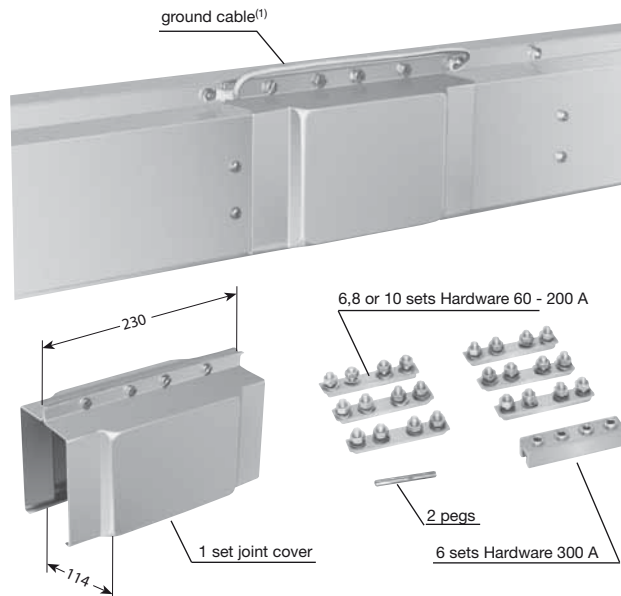

Type		Weight kg	Order- No.	Order- No. anodized
<b>VLGS 6/7</b>	for 6- and 7-pole	0,665	184 113	-
<b>VLGS/E 6/7</b>	60-200 Amp.	0,665	-	184 121
<b>VLGS 8/9</b>	for 8- and 9-pole	0,720	184 115	-
<b>VLGS/E 8/9</b>	60-200 Amp.	0,720	-	184 125
<b>VLGS 10/11</b>	for 10- and 11-pole	0,770	184 117	-
<b>VLGS/E 10/11</b>	60-200 Amp.	0,770	-	184 127
<b>VLGSG 6/7</b>	for 6- and 7-pole	0,890	184 119	-
<b>VLGSG/E 6/7</b>	300 Amp.	0,890	-	184 122

(1) Yellow/green ground cable factory pre-assembled.  
 (2) No joints required for uninsulated top conductors 5, 7, 9 and 11.  
 Equal for power line and control line.



# BRACKETS

These brackets are easily bolted to any type of standard I-beam.

View without I-beam

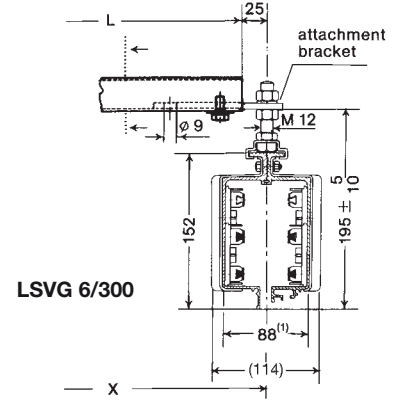
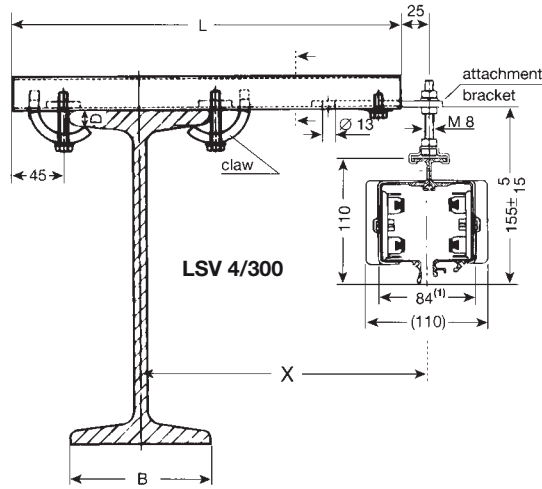
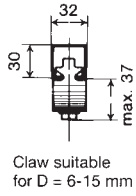

View without I-beam

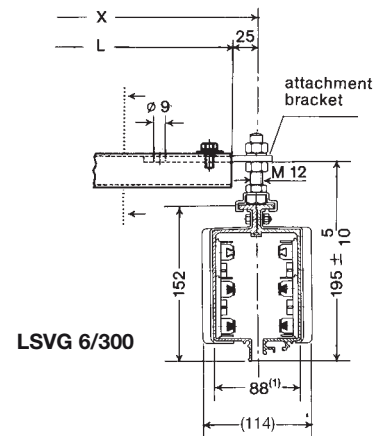
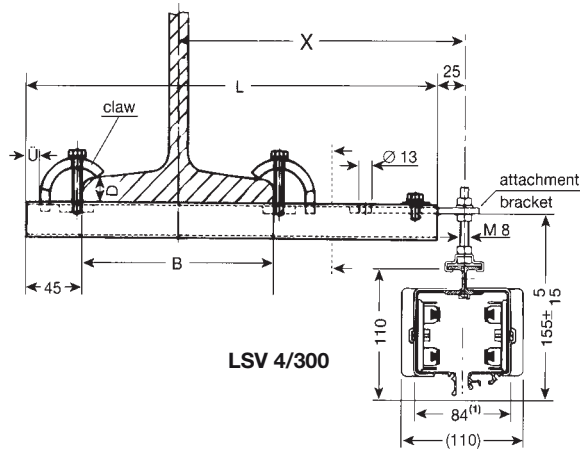
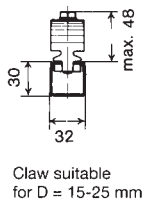

## EHLK small claw version

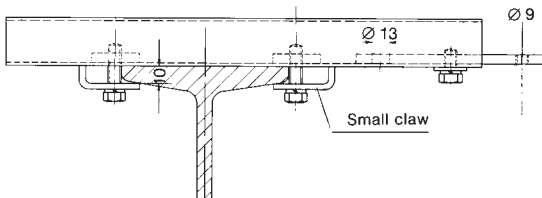

**Attention:**  
Make sure that hoist wheels have enough clearance.  
Use small claw if necessary!

□ -rail of EHLK is identical to type S 1, Order- No.

Select next larger size bracket when your I-beam dimension B is more than 170 mm and up to 300 mm.

	Type	X mm	L mm	B max. mm	Weight kg	Order- No. for std. brackets	Order- No. with small claw	
LSV	LSVG	EHK 250	250	350	170	1,070	251 600	251 720
		EHK 300	300	400	170	1,150	251 610	251 730
		EHK 400	400	500	170	1,300	251 620	251 740
		EHK 500	500	600	170	1,450	251 630	251 750
	EHK 600	600	700	170	1,600	251 640	251 760	
	EHK 700	700	800	170	1,750	251 650	251 770	
	EHK 750	750	850	170	1,820	251 660	251 780	
	EHK 800	800	900	170	1,900	251 670	251 790	

(1) max. width 84 mm resp. 88 mm for plug-in joints w/o joint plates.  
Dim. in parenthesis refer to bolted joints with joint plates (see illustration).

# FIXPOINT HANGER<sup>(1)</sup>

# SLIDING HANGER<sup>(1)</sup>



LSV

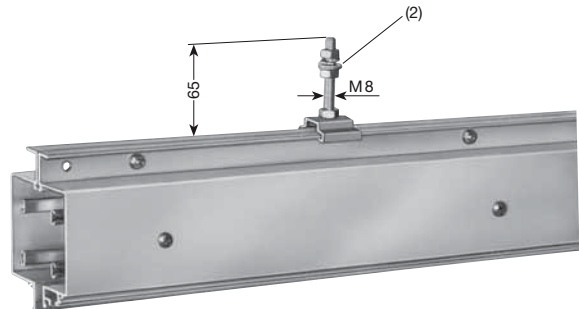
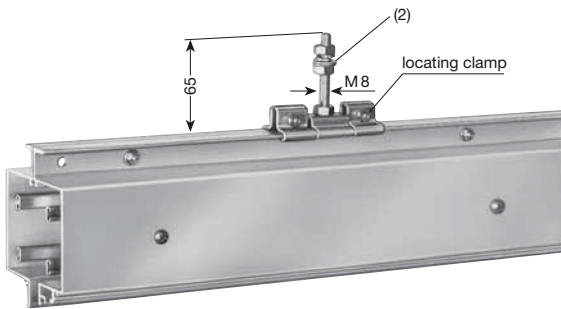

Type	Weight kg	Order- No.
<b>FAL</b>	0,150	190 120

Type	Weight kg	Order- No.
<b>GAL</b>	0,080	190 130

All steel parts made of stainless steel.

All steel parts made of stainless steel.

LSVG

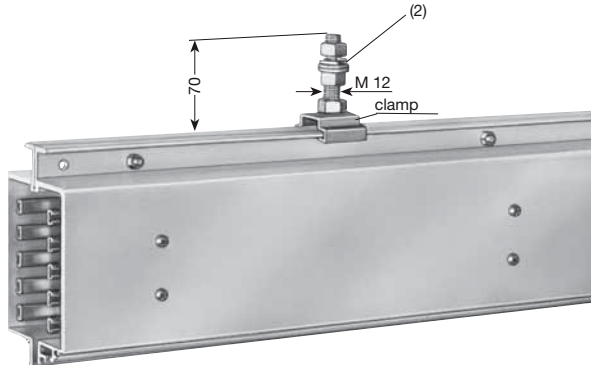
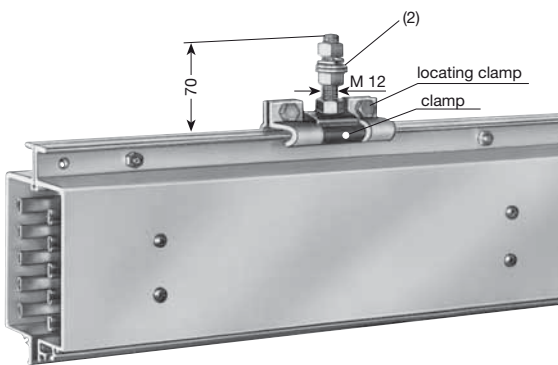

Type	Weight kg	Order- No.
<b>SAFG</b>	0,410	180 310

Type	Weight kg	Order- No.
<b>SAS</b>	0,175	200 160

Steel parts galvanized, clamp made of stainless steel.

Steel parts galvanized, clamp made of stainless steel.

<sup>(1)</sup> Illustrations show hangers mounted to powerail.  
<sup>(2)</sup> Flat washers only to be used in slotted holes.



# END CAP<sup>(1)</sup>

# END FEED<sup>(2)</sup>

€/w 1 m Powerail

LSV



Plastic cap with plug-in joints

Type	Weight kg	Order- No.
<b>EKL</b>	0,080	190 220



Aluminium cap with bolted joints

Type	Weight kg	Order- No.
<b>EKLS</b>	0,300	195 149
<b>EKLS/E</b>	0,300	195 303

L = LH version, R = RH version  
(see page 6)

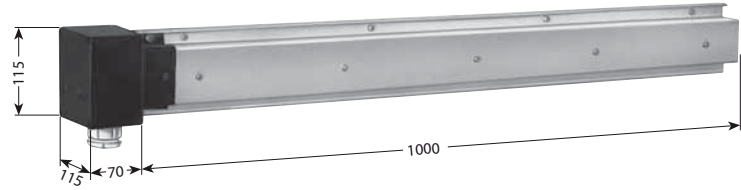

**Cable glands** (cable Ø see table page 28):  
4 & 5pole 1 x M 32  
6 & 7pole 1 x M 32  
and 1 x M 255

Type <sup>(3)</sup>	Order- No.	Type <sup>(3)</sup>	A	Weight kg	Order- No.
Power line <b>HS</b> with PE		Power line <b>HS</b> with PE			
<b>KEL 4/60 L</b>	192 150	<b>KEL 4/60 R</b>	60	3.35	190 140
<b>KEL 5/60 L</b>	192 160	<b>KEL 5/60 R</b>	60	3.55	190 150
<b>KEL 6/60 L</b>	192 170	<b>KEL 6/60 R</b>	60	3.75	190 160
<b>KEL 7/60 L</b>	192 180	<b>KEL 7/60 R</b>	60	3.95	190 170
Control line <b>SS</b> without PE		Control line <b>SS</b> without PE			
<b>KEL 4/60 L</b>	190 240	<b>KEL 4/60 R</b>	60	3.35	190 250
<b>KEL 6/60 L</b>	190 260	<b>KEL 6/60 R</b>	60	3.75	190 390

LSVG



Plastic cap with plug-in joints

Type	Weight kg	Order- No.
<b>EKLG</b>	0,120	180 320



Aluminium cap with bolted joints

Type	Weight kg	Order- No.
<b>EKLS</b>	0,450	184 100
<b>EKLS/E</b>	0,450	184 177

L = LH version <sup>(1)</sup>, R = RH version  
(see page 6)

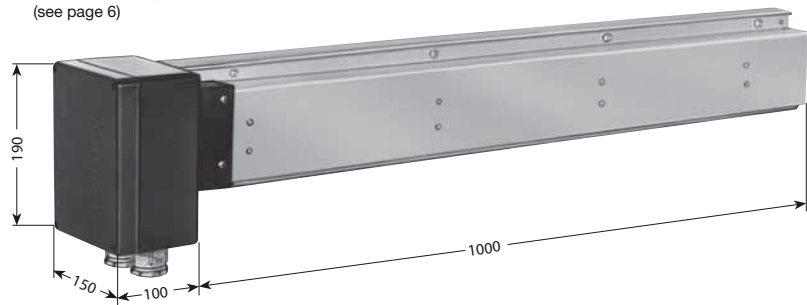

**Cable glands** (cable Ø see table page 28):  
all types 1 x M 32  
and 1 x M 25

Type <sup>(3)</sup>	Order- No.	Type <sup>(3)</sup>	A	Weight kg	Order- No.
Power line <b>HS</b> with PE		Power line <b>HS</b> with PE			
<b>KELG 6/60 L</b>	180 330	<b>KELG 6/60 R</b>	60	6.05	180 340
<b>KELG 7/60 L</b>	180 350	<b>KELG 7/60 R</b>	60	6.25	180 360
<b>KELG 8/60 L</b>	180 370	<b>KELG 8/60 R</b>	60	6.40	180 380
<b>KELG 9/60 L</b>	180 430	<b>KELG 9/60 R</b>	60	6.60	180 440
<b>KELG 10/60 L</b>	180 450	<b>KELG 10/60 R</b>	60	6.80	180 460
<b>KELG 11/60 L</b>	180 470	<b>KELG 11/60 R</b>	60	7.00	180 480
Control line <b>SS</b> without PE		Control line <b>SS</b> without PE			
<b>KELG 6/60 L</b>	180 390	<b>KELG 6/60 R</b>	60	6.05	180 400
<b>KELG 8/60 L</b>	180 410	<b>KELG 8/60 R</b>	60	6.40	180 420
<b>KELG 10/60 L</b>	180 490	<b>KELG 10/60 R</b>	60	6.80	180 500

<sup>(1)</sup> Illustration shows end cap with standard section.

<sup>(2)</sup> Above sections come ready assembled on 1m section and are part of the system length (see examples for ordering pages 26 and 27).

<sup>(3)</sup> Suffix types e.g. KEL 4/60 L w/ PE → KEL 4/60 L **HS** Order- No. 192 150.

# LINE FEED<sup>(1)</sup>

c/w 2 m feed-in cable and 1 m Powerail

# LINE FEED<sup>(1)</sup>

c/w terminal box and 1 m Powerail



LSV

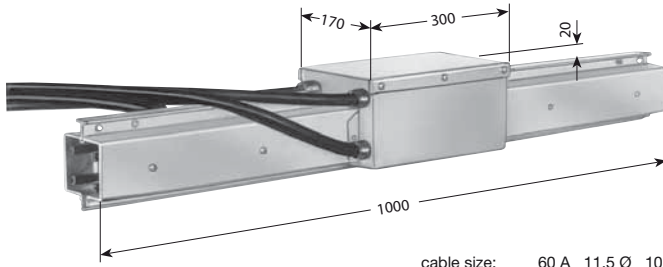

cable size: 60 A 11.5 Ø 10 mm<sup>2</sup>  
100 A 13.5 Ø 25 mm<sup>2</sup>  
140 A 14.5 Ø 35 mm<sup>2</sup>  
200 A 18.0 Ø 50 mm<sup>2</sup>

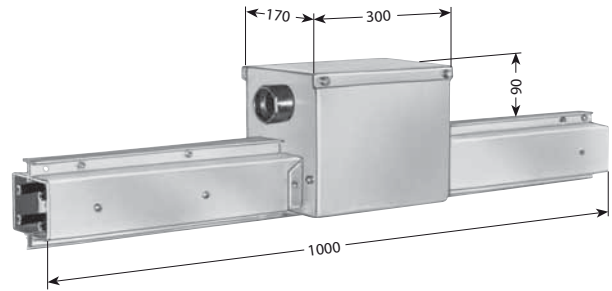

**Cable glands** (cable-Ø see table page 28)  
4 + 5pole 1 x M 32 power line 60 A  
4 + 5pole 1 x M 50 power line 100 und 140 A  
4 + 5pole 1 x M 50 power line 200 A  
4 + 5pole 1 x M 63 power line 300 A  
6 + 7pole 1 x M 32 and 1 x M 25 power line 60 A  
6 + 7pole 1 x M 50 and 1 x M 25 power line 100 und 140 A  
6 + 7pole 1 x M 50 and 1 x M 25 power line 200 A  
4 + 6pole 1 x M 32 control line 60 A

Type <sup>(2)</sup>	A	Weight kg	Order- No.	Type <sup>(2)</sup>	A	Weight kg	Order- No.	Type <sup>(2)</sup>	A	Weight kg	Order- No.	Type <sup>(2)</sup>	A	Weight kg	Order- No.
Power line <b>HS</b> with PE				Power line <b>HS</b> with PE				Power line <b>HS</b> with PE				Power line <b>HS</b> with PE			
LAL 4/ 60	60	5,65	195 060	LAL 6/ 60	60	6,65	195 067	NKL 4/ 60	60	4,40	195 074	NKL 6/ 60	60	4,80	195 085
LAL 4/100	100	6,55	195 061	LAL 6/100	100	7,80	195 068	NKL 4/100	100	4,80	195 075	NKL 6/100	100	5,20	195 086
LAL 4/140	140	7,40	195 062	LAL 6/140	140	8,45	195 069	NKL 4/140	140	5,10	195 076	NKL 6/140	140	5,50	195 087
LAL 4/200	200	8,00	195 637	LAL 6/200	200	8,95	195 639	NKL 4/200	200	5,80	195 077	NKL 6/200	200	6,00	195 567
LAL 5/ 60	60	6,10	195 064	LAL 7/ 60	60	7,15	195 071	NKL 4/300	300	6,50	195 078	NKL 7/ 60	60	5,00	195 089
LAL 5/100	100	7,00	195 065	LAL 7/100	100	9,00	195 072	NKL 5/ 60	60	4,60	195 080	NKL 7/100	100	5,40	195 090
LAL 5/140	140	8,25	195 066	LAL 7/140	140	9,25	195 073	NKL 5/100	100	5,00	195 081	NKL 7/140	140	5,70	195 091
LAL 5/200	200	8,85	195 638	LAL 7/200	200	9,80	195 640	NKL 5/140	140	5,30	195 082	NKL 7/200	200	6,30	195 568
Control line <b>SS</b> without PE												Control line <b>SS</b> without PE			
LAL 4/ 60	60	5,65	195 063									NKL 4/ 60	60	4,40	195 079
LAL 6/ 60	60	6,65	195 070									NKL 6/ 60	60	4,80	195 088

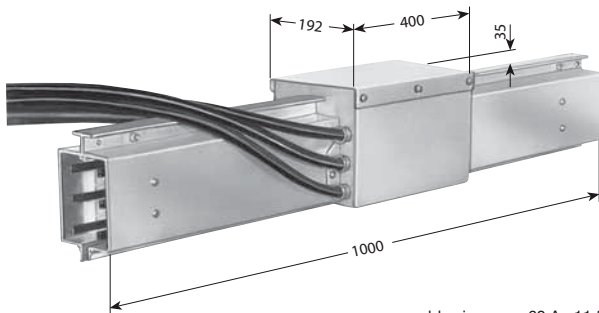

cable size: 60 A 11.5 Ø 10 mm<sup>2</sup>  
100 A 13.5 Ø 25 mm<sup>2</sup>  
140 A 14.5 Ø 35 mm<sup>2</sup>  
200 A 18.0 Ø 50 mm<sup>2</sup>

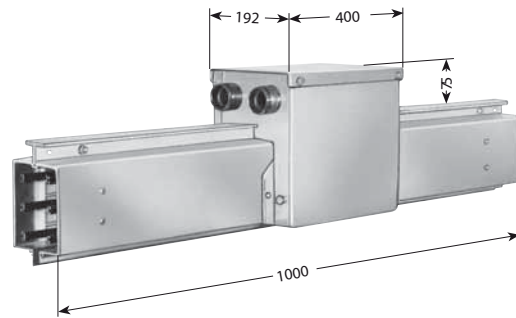

**Cable glands** (cable-Ø see table page 28)  
6-11pole 1 x M 32 and 1 x M 25 power line 60 A  
6-11pole 1 x M 50 and 1 x M 25 power line 100 und 140 A  
6+ 7pole 1 x M 50 and 1 x M 25 power line 200 A  
6+ 7pole 1 x M 63 and 1 x M 25 power line 300 A  
6, 8 and 10pole 2 x M 25 control line 60 A

LSVG

Type <sup>(2)</sup>	A	Weight kg	Order- No.	Typ <sup>(2)</sup>	A	Weight kg	Order- No.	Typ <sup>(2)</sup>	A	Weight kg	Order- No.	Typ <sup>(2)</sup>	A	Weight kg	Order- No.
Power line <b>HS</b> with PE				Power line <b>HS</b> with PE				Power line <b>HS</b> with PE				Power line <b>HS</b> with PE			
LALG 6/ 60	60	8,60	183 949	LALG 9/ 60	60	10,15	183 960	NKLG 6/ 60	60	6,75	184 983	NKLG 9/ 60	60	7,35	185 049
LALG 6/100	100	9,40	183 950	LALG 9/100	100	11,05	183 961	NKLG 6/100	100	7,05	184 985	NKLG 9/100	100	7,65	185 051
LALG 6/140	140	10,30	183 951	LALG 9/140	140	12,15	183 962	NKLG 6/140	140	7,35	185 029	NKLG 9/140	140	7,95	185 053
LALG 6/200	200	10,80	184 661	LALG 9/200	200	12,70	184 664	NKLG 6/200	200	7,90	185 031	NKLG 9/200	200	8,50	185 055
LALG 7/ 60	60	9,10	183 953	LALG 10/ 60	60	10,65	183 963	NKLG 6/300	300	8,85	185 079	NKLG 10/ 60	60	7,55	185 057
LALG 7/100	100	10,10	183 954	LALG 10/100	100	11,45	183 964	NKLG 7/ 60	60	6,95	185 033	NKLG 10/100	100	7,85	185 059
LALG 7/140	140	11,10	183 955	LALG 10/140	140	12,30	183 965	NKLG 7/100	100	7,25	185 035	NKLG 10/140	140	8,15	185 061
LALG 7/200	200	11,65	184 662	LALG 10/200	200	12,80	184 665	NKLG 7/140	140	7,55	185 037	NKLG 10/200	200	8,65	185 063
LALG 8/ 60	60	9,60	183 956	LALG 11/ 60	60	11,15	183 967	NKLG 7/200	200	8,10	185 039	NKLG 11/ 60	60	7,75	185 065
LALG 8/100	100	10,45	183 957	LALG 11/100	100	12,10	183 968	NKLG 7/300	300	9,05	185 081	NKLG 11/100	100	8,05	185 067
LALG 8/140	140	11,30	183 958	LALG 11/140	140	13,15	183 969	NKLG 8/ 60	60	7,15	185 041	NKLG 11/140	140	8,35	185 069
LALG 8/200	200	11,80	184 663	LALG 11/200	200	13,70	184 666	NKLG 8/100	100	7,45	185 043	NKLG 11/200	200	8,90	185 071
Control line <b>SS</b> without PE												Control line <b>SS</b> without PE			
LALG 6/60	60	8,60	183 952									NKLG 6/ 60	60	6,75	185 073
LALG 8/60	60	9,60	183 959									NKLG 8/ 60	60	7,15	185 075
LALG 10/60	60	10,65	183 966									NKLG 10/ 60	60	7,55	185 077

<sup>(1)</sup> Above sections come ready assembled on 1 m Powerail section and are a part of the system length (see examples for ordering on pages 26 and 27).

<sup>(2)</sup> Suffix types e.g. LAL 4/60 w/ PE → LAL 4/60 **HS** Order- No. 195 060.



# TRANSFER AND SWITCH ARRANGEMENTS

## Contact section<sup>(1)</sup>

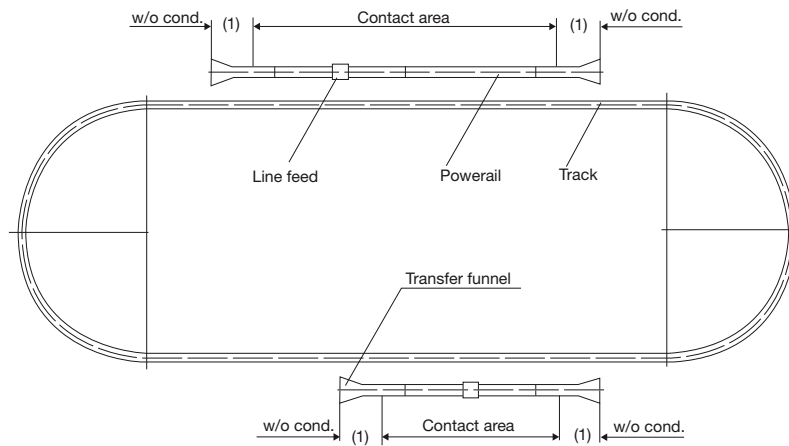

## Turntable

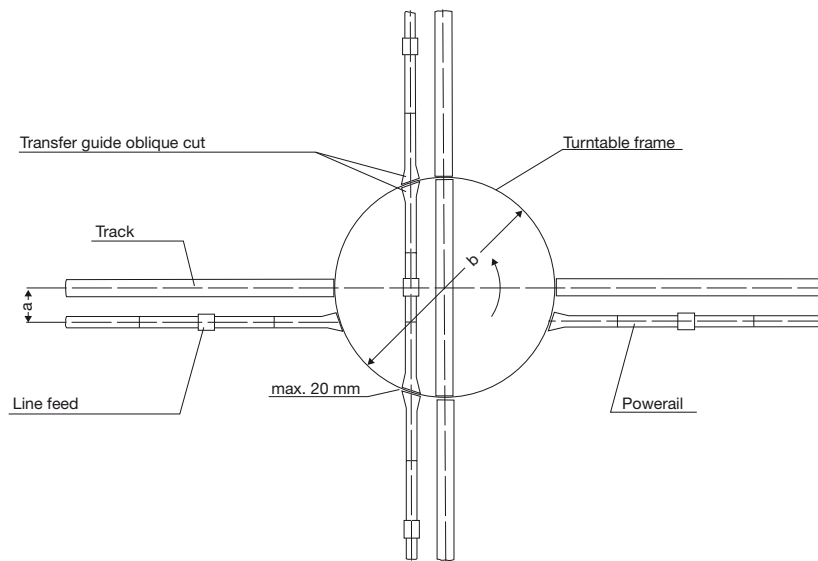

## Sliding switch

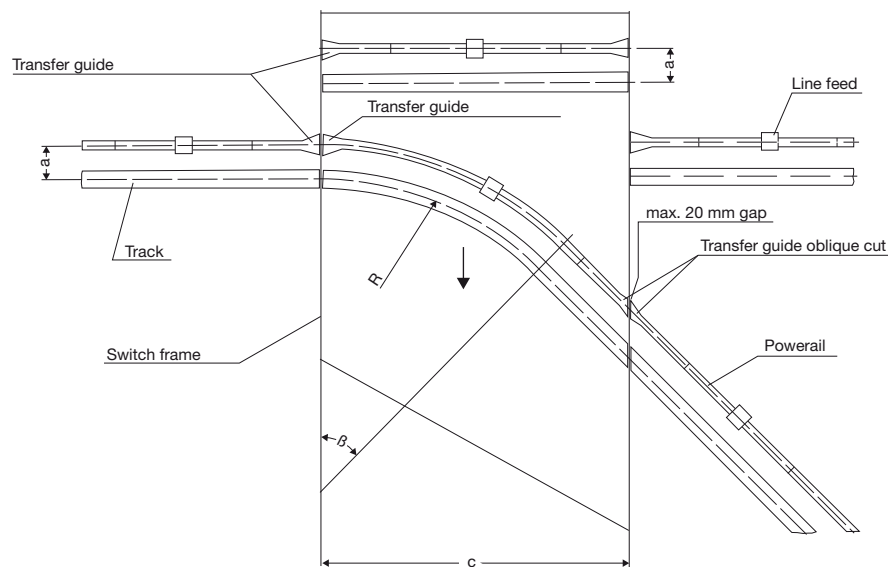

Please submit drawings of transfer applications. Specify dimensions a, b, c, R and angle a (a max. 50°)

<sup>(1)</sup> Transfer funnels must not be activated before collectors are fully engaged. Flexible support type tow arms (see page 22) for collectors are essential with contact sections.

# TRANSFER FUNNEL(2) c/w 0.5 m Powerail and joint material



LSV

for horizontal offset max. 15 mm  
for vertical offset max. 10 mm  
KFM or KFML tow arm (see page 22) required; applications see page 12.

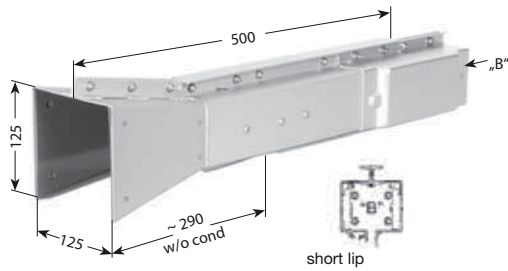

Illustration shows L. H. version  
short lip in front  
(see page 6)

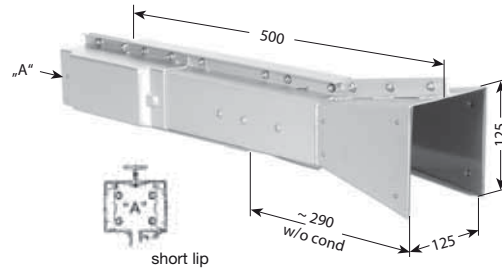

Illustration shows R. H. version  
short lip in front  
(see page 6)

Type <sup>(2)</sup>	Weight kg	Order- No.	Type <sup>(2)</sup>	Weight kg	Order- No.	Type <sup>(2)</sup>	Weight kg	Order- No.	Type <sup>(2)</sup>	Weight kg	Order- No.
Power line HS with PE			Power line HS with PE			Power line HS with PE			Power line HS with PE		
ETL 4/ 60 L	1,450	192 890	ETL 6/ 60 L	1,500	192 990	ETL 4/ 60 R	1,450	193 070	ETL 6/ 60 R	1,500	193 170
ETL 4/100 L	1,500	192 900	ETL 6/100 L	1,600	193 000	ETL 4/100 R	1,500	193 080	ETL 6/100 R	1,600	193 180
ETL 4/140 L	1,600	192 910	ETL 6/140 L	1,650	193 010	ETL 4/140 R	1,600	193 090	ETL 6/140 R	1,650	193 190
ETL 4/200 L	1,700	192 920	ETL 6/200 L	1,750	195 610	ETL 4/200 R	1,700	193 100	ETL 6/200 R	1,750	195 611
ETL 4/300 L	1,800	192 930	ETL 7/ 60 L	1,550	193 020	ETL 4/300 R	1,800	193 110	ETL 7/ 60 R	1,550	193 200
ETL 5/ 60 L	1,500	192 940	ETL 7/100 L	1,600	193 030	ETL 5/ 60 R	1,500	193 120	ETL 7/100 R	1,600	193 210
ETL 5/100 L	1,550	192 950	ETL 7/140 L	1,700	193 040	ETL 5/100 R	1,550	193 130	ETL 7/140 R	1,700	193 220
ETL 5/140 L	1,650	192 960	ETL 7/200 L	1,820	195 612	ETL 5/140 R	1,650	193 140	ETL 7/200 R	1,820	195 613
ETL 5/200 L	1,750	192 970	Control line SS without PE			ETL 5/200 R	1,750	193 150	Control line SS without PE		
ETL 5/300 L	1,900	192 980	ETL 4/ 60 L	1,450	193 050	ETL 5/300 R	1,900	193 160	ETL 4/ 60 R	1,450	193 230
			ETL 6/ 60 L	1,500	193 060				ETL 6/ 60 R	1,500	193 240

for horizontal offset max. 15 mm  
for vertical offset max. 10 mm  
GFM tow arm required; applications see page 12, 22

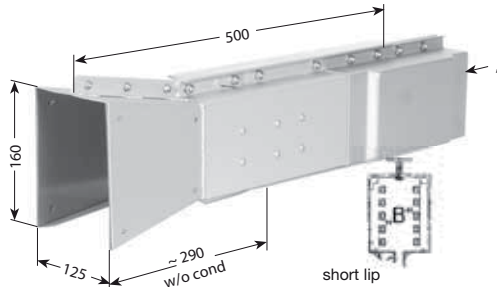

Illustration shows L. H. version  
short lip in front  
(see page 6)

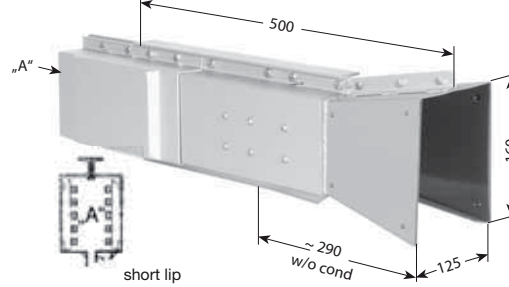

Illustration shows R. H. version  
short lip in front  
(see page 6)

Type <sup>(2)</sup>	Weight kg	Order- No.	Type <sup>(2)</sup>	Weight kg	Order- No.	Type <sup>(2)</sup>	Weight kg	Order- No.	Type <sup>(2)</sup>	Weight kg	Order- No.
Power line HS with PE			Power line HS with PE			Power line HS with PE			Power line HS with PE		
ETLG 6/ 60 L	2,500	181 970	ETLG 9/ 60 L	2,600	182 230	ETLG 6/ 60 R	2,500	181 980	ETLG 9/ 60 R	2,600	182 240
ETLG 6/100 L	2,550	181 990	ETLG 9/100 L	2,700	182 250	ETLG 6/100 R	2,550	182 000	ETLG 9/100 R	2,700	182 260
ETLG 6/140 L	2,650	182 010	ETLG 9/140 L	2,750	182 270	ETLG 6/140 R	2,650	182 020	ETLG 9/140 R	2,750	182 280
ETLG 6/200 L	2,750	182 030	ETLG 9/200 L	2,870	184 621	ETLG 6/200 R	2,750	182 040	ETLG 9/200 R	2,870	184 625
ETLG 6/300 L	2,950	182 050	ETLG 10/ 60 L	2,650	182 290	ETLG 6/300 R	2,950	182 060	ETLG 10/ 60 R	2,650	182 300
ETLG 7/ 60 L	2,550	182 070	ETLG 10/100 L	2,700	182 310	ETLG 7/ 60 R	2,550	182 080	ETLG 10/100 R	2,700	182 320
ETLG 7/100 L	2,600	182 090	ETLG 10/140 L	2,750	182 330	ETLG 7/100 R	2,600	182 100	ETLG 10/140 R	2,750	182 340
ETLG 7/140 L	2,700	182 110	ETLG 10/200 L	2,850	184 622	ETLG 7/140 R	2,700	182 120	ETLG 10/200 R	2,850	184 626
ETLG 7/200 L	2,800	182 130	ETLG 11/ 60 L	2,650	182 350	ETLG 7/200 R	2,800	182 140	ETLG 11/ 60 R	2,650	182 360
ETLG 7/300 L	2,950	182 150	ETLG 11/100 L	2,750	182 370	ETLG 7/300 R	2,950	182 160	ETLG 11/100 R	2,750	182 380
ETLG 8/ 60 L	2,600	182 170	ETLG 11/140 L	2,800	182 390	ETLG 8/ 60 R	2,600	182 180	ETLG 11/140 R	2,800	182 400
ETLG 8/100 L	2,650	182 190	ETLG 11/200 L	2,920	184 623	ETLG 8/100 R	2,650	182 200	ETLG 11/200 R	2,920	184 627
ETLG 8/140 L	2,700	182 210	Control line SS without PE			ETLG 8/140 R	2,700	182 220	Control line SS without PE		
ETLG 8/200 L	2,800	184 620	ETLG 6/ 60 L	2,500	182 410	ETLG 8/200 R	2,800	184 624	ETLG 6/ 60 R	2,500	182 420
			ETLG 8/ 60 L	2,600	182 430				ETLG 8/ 60 R	2,600	182 440
			ETLG 10/ 60 L	2,650	182 450				ETLG 10/ 60 R	2,650	182 460

(1) All transfer funnels are 0.5 m long and are a part of the system length.  
(2) Suffix types e.g. ETL 4/60 w/ PE → ETL 4/60 HS Order- No. 192 890.



# TRANSFER GUIDE, STRAIGHT CUT<sup>(1)</sup>

€ / w 0.5 m Powerail

LSV

for turntables, switches and spurlines,  
staggered arrangement of the transfer  
guides to each other: horizontal max. 5 mm, vertical max. 3 mm  
applications see page 12

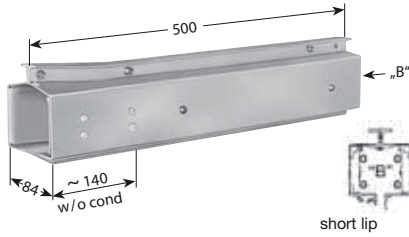

Illustration shows L. H. version  
short lip in front  
(see page 6)

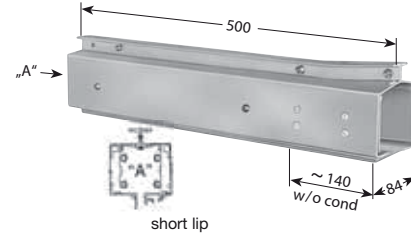

Illustration shows R. H. version  
short lip in front  
(see page 6)

Type <sup>(2)</sup>	Weight kg	Order- No.	Type <sup>(2)</sup>	Weight kg	Order- No.	Type <sup>(2)</sup>	Weight kg	Order- No.	Type <sup>(2)</sup>	Weight kg	Order- No.
Power line <b>HS</b> with PE			Power line <b>HS</b> with PE			Power line <b>HS</b> with PE			Power line <b>HS</b> with PE		
AÜL 4/ 60 L	1,400	192 190	AÜL 6/ 60 L	1,500	192 390	AÜL 4/ 60 R	1,400	192 200	AÜL 6/ 60 R	1,500	192 400
AÜL 4/100 L	1,550	192 210	AÜL 6/100 L	1,650	192 410	AÜL 4/100 R	1,550	192 220	AÜL 6/100 R	1,650	192 420
AÜL 4/140 L	1,650	192 230	AÜL 6/140 L	1,750	192 430	AÜL 4/140 R	1,650	192 240	AÜL 6/140 R	1,750	192 440
AÜL 4/200 L	1,800	192 250	AÜL 6/200 L	1,900	195 614	AÜL 4/200 R	1,800	192 260	AÜL 6/200 R	1,900	195 615
AÜL 4/300 L	2,050	192 270	AÜL 7/ 60 L	1,550	192 450	AÜL 4/300 R	2,050	192 280	AÜL 7/ 60 R	1,550	192 460
AÜL 5/ 60 L	1,450	192 290	AÜL 7/100 L	1,700	192 470	AÜL 5/ 60 R	1,450	192 300	AÜL 7/100 R	1,700	192 480
AÜL 5/100 L	1,600	192 310	AÜL 7/140 L	1,850	192 490	AÜL 5/100 R	1,600	192 320	AÜL 7/140 R	1,850	192 500
AÜL 5/140 L	1,750	192 330	AÜL 7/200 L	2,020	195 616	AÜL 5/140 R	1,750	192 340	AÜL 7/200 R	2,020	195 617
AÜL 5/200 L	1,950	192 350	Control line <b>SS</b> without PE			AÜL 5/200 R	1,950	192 360	Control line <b>SS</b> without PE		
AÜL 5/300 L	2,150	192 370	AÜL 4/ 60 L	1,400	192 510	AÜL 5/300 R	2,150	192 380	AÜL 4/ 60 R	1,400	192 520
			AÜL 6/ 60 L	1,500	192 530				AÜL 6/ 60 R	1,500	192 540

LSVG

for turntables, switches and spurlines,  
staggered arrangement of the transfer  
guides to each other: horizontal max. 5 mm, vertical max. 3 mm  
applications see page 12

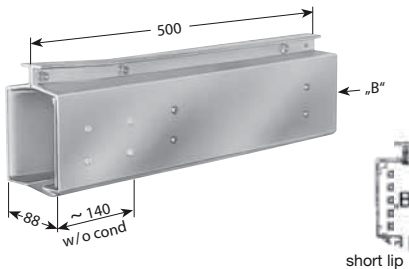

Illustration shows L. H. version  
short lip in front  
(see page 6)

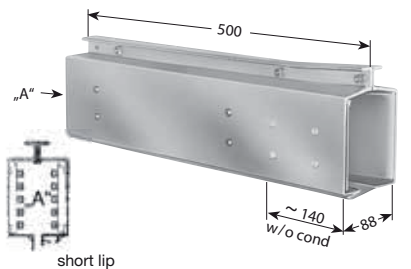

Illustration shows R. H. version  
short lip in front  
(see page 6)

Type <sup>(2)</sup>	Weight kg	Order- No.	Type <sup>(2)</sup>	Weight kg	Order- No.	Type <sup>(2)</sup>	Weight kg	Order- No.	Type <sup>(2)</sup>	Weight kg	Order- No.
Power line <b>HS</b> with PE			Power line <b>HS</b> with PE			Power line <b>HS</b> with PE			Power line <b>HS</b> with PE		
AÜLG 6/ 60 L	2,500	180 970	AÜLG 9/ 60 L	2,700	181 230	AÜLG 6/ 60 R	2,500	180 980	AÜLG 9/ 60 R	2,700	181 240
AÜLG 6/100 L	2,600	180 990	AÜLG 9/100 L	2,800	181 250	AÜLG 6/100 R	2,600	181 000	AÜLG 9/100 R	2,800	181 260
AÜLG 6/140 L	2,700	181 010	AÜLG 9/140 L	2,950	181 270	AÜLG 6/140 R	2,700	181 020	AÜLG 9/140 R	2,950	181 280
AÜLG 6/200 L	2,900	181 030	AÜLG 9/200 L	3,120	184 629	AÜLG 6/200 R	2,900	181 040	AÜLG 9/200 R	3,120	184 633
AÜLG 6/300 L	3,250	181 050	AÜLG 10/ 60 L	2,750	181 290	AÜLG 6/300 R	3,250	181 060	AÜLG 10/ 60 R	2,750	181 300
AÜLG 7/ 60 L	2,550	181 070	AÜLG 10/100 L	2,850	181 310	AÜLG 7/ 60 R	2,550	181 080	AÜLG 10/100 R	2,850	181 320
AÜLG 7/100 L	2,700	181 090	AÜLG 10/140 L	2,950	181 330	AÜLG 7/100 R	2,700	181 100	AÜLG 10/140 R	2,950	181 340
AÜLG 7/140 L	2,850	181 110	AÜLG 10/200 L	3,100	184 630	AÜLG 7/140 R	2,850	181 120	AÜLG 10/200 R	3,100	184 634
AÜLG 7/200 L	3,050	181 130	AÜLG 11/ 60 L	2,800	181 350	AÜLG 7/200 R	3,050	181 140	AÜLG 11/ 60 R	2,800	181 360
AÜLG 7/300 L	3,300	181 150	AÜLG 11/100 L	2,900	181 370	AÜLG 7/300 R	3,300	181 160	AÜLG 11/100 R	2,900	181 380
AÜLG 8/ 60 L	2,600	181 170	AÜLG 11/140 L	3,050	181 390	AÜLG 8/ 60 R	2,600	181 180	AÜLG 11/140 R	3,050	181 400
AÜLG 8/100 L	2,700	181 190	AÜLG 11/200 L	3,220	184 631	AÜLG 8/100 R	2,700	181 200	AÜLG 11/200 R	3,220	184 635
AÜLG 8/140 L	2,850	181 210	Control line <b>SS</b> without PE			AÜLG 8/140 R	2,850	181 220	Control line <b>SS</b> without PE		
AÜLG 8/200 L	3,000	184 628	AÜLG 6/ 60 L	2,500	181 410	AÜLG 8/200 R	3,000	184 632	AÜLG 6/ 60 R	2,500	181 420
			AÜLG 8/ 60 L	2,600	181 430				AÜLG 8/ 60 R	2,600	181 440
			AÜLG 10/ 60 L	2,750	181 450				AÜLG 10/ 60 R	2,750	181 460

<sup>(1)</sup> All transfer guides are 0.5 m long and are a part of the system length (see examples for ordering pages 26 and 27).  
Always use double collectors for transfer applications (see page 21).

<sup>(2)</sup> Suffix types e.g. AÜL 4/60 L w/ PE → AÜL 4/60 L **HS** Order- No. 192 190.

# TRANSFER GUIDE, OBLIQUE CUT<sup>(1)</sup>

c/w 0.5 m Powerail



LSV

for turntables, switches and spurlines,  
staggered arrangement of the transfer  
guides to each other: horizontal max. 5 mm,  
vertical max. 3 mm  
applications see page 12

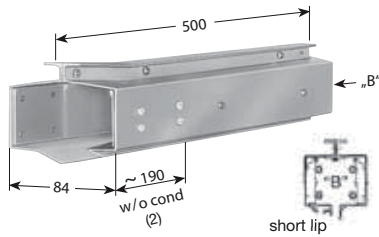

Illustration shows L. H. version  
short lip in front  
(see page 6)

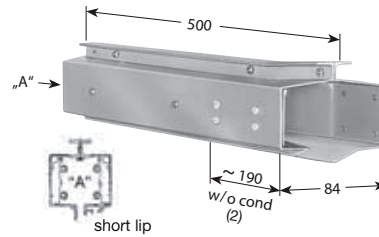

Illustration shows R. H. version  
short lip in front  
(see page 6)

Type <sup>(2)</sup>	Weight kg	Order- No.	Type <sup>(2)</sup>	Weight kg	Order- No.	Type <sup>(2)</sup>	Weight kg	Order- No.	Type <sup>(2)</sup>	Weight kg	Order- No.
Power line HS with PE			Power line HS with PE			Power line HS with PE			Power line HS with PE		
AÜLS 4/ 60 L	1,400	192 550	AÜLS 6/ 60 L	1,500	192 750	AÜLS 4/ 60 R	1,400	192 560	AÜLS 6/ 60 R	1,500	192 760
AÜLS 4/100 L	1,550	192 570	AÜLS 6/100 L	1,650	192 770	AÜLS 4/100 R	1,550	192 580	AÜLS 6/100 R	1,650	192 780
AÜLS 4/140 L	1,650	192 590	AÜLS 6/140 L	1,750	193 420	AÜLS 4/140 R	1,650	192 600	AÜLS 6/140 R	1,750	193 430
AÜLS 4/200 L	1,800	192 610	AÜLS 6/200 L	1,900	195 618	AÜLS 4/200 R	1,800	192 620	AÜLS 6/200 R	1,900	195 619
AÜLS 4/300 L	2,050	192 630	AÜLS 7/ 60 L	1,550	192 790	AÜLS 4/300 R	2,050	192 640	AÜLS 7/ 60 R	1,550	192 800
AÜLS 5/ 60 L	1,450	192 650	AÜLS 7/100 L	1,700	192 810	AÜLS 5/ 60 R	1,450	192 660	AÜLS 7/100 R	1,700	192 820
AÜLS 5/100 L	1,600	192 670	AÜLS 7/140 L	1,850	192 830	AÜLS 5/100 R	1,600	192 680	AÜLS 7/140 R	1,850	192 840
AÜLS 5/140 L	1,750	192 690	AÜLS 7/200 L	2,020	195 620	AÜLS 5/140 R	1,750	192 700	AÜLS 7/200 R	2,020	195 621
AÜLS 5/200 L	1,950	192 710	Control line SS without PE			AÜLS 5/200 R	1,950	192 720	Control line SS without PE		
AÜLS 5/300 L	2,150	192 730	AÜLS 4/ 60 L	1,400	192 850	AÜLS 5/300 R	2,150	192 740	AÜLS 4/ 60 R	1,400	192 860
			AÜLS 6/ 60 L	1,500	192 870				AÜLS 6/ 60 R	1,500	192 880

for turntables, switches and spurlines,  
staggered arrangement of the transfer  
guides to each other: horizontal max. 5 mm,  
vertical max. 3 mm  
applications see page 12

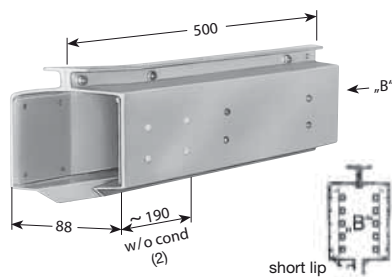

Illustration shows L. H. version  
short lip in front  
(see page 6)

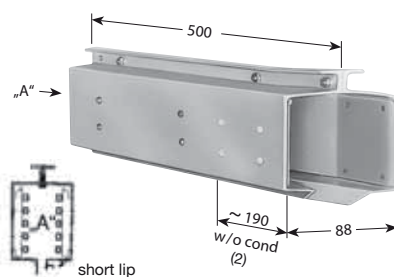

Illustration shows R. H. version  
short lip in front  
(see page 6)

Type <sup>(2)</sup>	Weight kg	Order- No.	Type <sup>(2)</sup>	Weight kg	Order- No.	Type <sup>(2)</sup>	Weight kg	Order- No.	Type <sup>(2)</sup>	Weight kg	Order- No.
Power line HS with PE			Power line HS with PE			Power line HS with PE			Power line HS with PE		
AÜLSG 6/ 60 L	2,500	181 470	AÜLSG 9/ 60 L	2,700	181 730	AÜLSG 6/ 60 R	2,500	181 480	AÜLSG 9/ 60 R	2,700	181 740
AÜLSG 6/100 L	2,600	181 490	AÜLSG 9/100 L	2,800	181 750	AÜLSG 6/100 R	2,600	181 500	AÜLSG 9/100 R	2,800	181 760
AÜLSG 6/140 L	2,700	181 510	AÜLSG 9/140 L	2,950	181 770	AÜLSG 6/140 R	2,700	181 520	AÜLSG 9/140 R	2,950	181 780
AÜLSG 6/200 L	2,900	181 530	AÜLSG 9/200 L	3,120	184 637	AÜLSG 6/200 R	2,900	181 540	AÜLSG 9/200 R	3,120	184 641
AÜLSG 6/300 L	3,250	181 550	AÜLSG 10/ 60 L	2,750	181 790	AÜLSG 6/300 R	3,250	181 560	AÜLSG 10/ 60 R	2,750	181 800
AÜLSG 7/ 60 L	2,550	181 570	AÜLSG 10/100 L	2,850	181 810	AÜLSG 7/ 60 R	2,550	181 580	AÜLSG 10/100 R	2,850	181 820
AÜLSG 7/100 L	2,700	181 590	AÜLSG 10/140 L	2,950	181 830	AÜLSG 7/100 R	2,700	181 600	AÜLSG 10/140 R	2,950	181 840
AÜLSG 7/140 L	2,850	181 610	AÜLSG 10/200 L	3,100	184 638	AÜLSG 7/140 R	2,850	181 620	AÜLSG 10/200 R	3,100	184 642
AÜLSG 7/200 L	3,050	181 630	AÜLSG 11/ 60 L	2,800	181 850	AÜLSG 7/200 R	3,050	181 640	AÜLSG 11/ 60 R	2,800	181 860
AÜLSG 7/300 L	3,300	181 650	AÜLSG 11/100 L	2,900	181 870	AÜLSG 7/300 R	3,300	181 660	AÜLSG 11/100 R	2,900	181 880
AÜLSG 8/ 60 L	2,600	181 670	AÜLSG 11/140 L	3,050	181 890	AÜLSG 8/ 60 R	2,600	181 680	AÜLSG 11/140 R	3,050	181 900
AÜLSG 8/100 L	2,700	181 690	AÜLSG 11/200 L	3,220	184 639	AÜLSG 8/100 R	2,700	181 700	AÜLSG 11/200 R	3,220	184 643
AÜLSG 8/140 L	2,850	181 710	Control line SS without PE			AÜLSG 8/140 R	2,850	181 720	Control line SS without PE		
AÜLSG 8/200 L	3,000	184 636	AÜLSG 6/ 60 L	2,500	181 910	AÜLSG 8/200 R	3,000	184 640	AÜLSG 6/ 60 R	2,500	181 920
			AÜLSG 8/ 60 L	2,600	181 930				AÜLSG 8/ 60 R	2,600	181 940
			AÜLSG 10/ 60 L	2,750	181 950				AÜLSG 10/ 60 R	2,750	181 960

<sup>(1)</sup> All transfer guides are 0.5 m long and are a part of the system length (see examples for ordering pages 26 and 27).  
Always use double collectors for transfer applications (see page 21).

<sup>(2)</sup> Suffix types e.g. AÜLS 4/60 L w/ PE → AÜLS 4/60 L HS Order- No. 192 550.

<sup>(3)</sup> Detailed drawings of switch, turntable etc. are required to manufacture oblique cut transfer guides and cut back conductors accordingly.



# HEATING SYSTEM

## Arrangement of heating cables

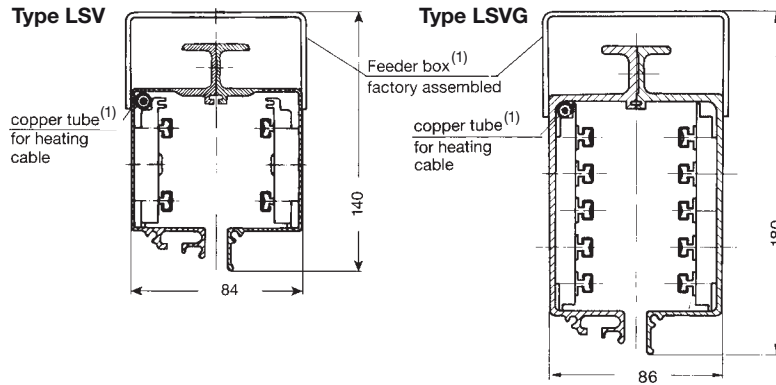

Heating systems are recommended for outdoor Powerail installations with icing conditions and for extremely humid environments. The heating is accomplished by heating conductors being arranged inside the Powerail housing as shown in the adjacent drawings.

The heating cables are pulled through the factory assembled copper tubes and connected to the terminal boxes during the installation process at site.

## Selection of the heating cable

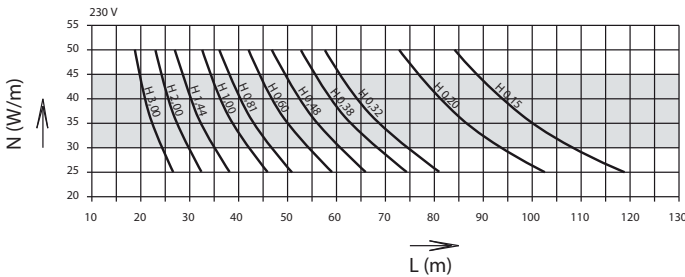
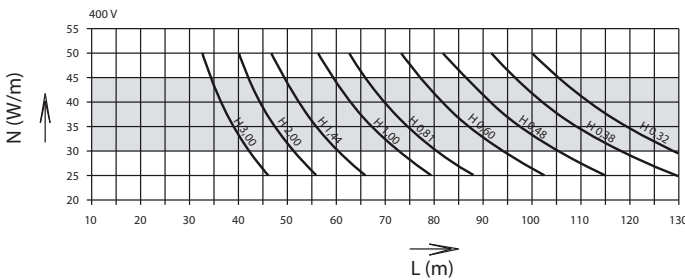

With shorter heating lengths please feed over a transformer with appropriate low secondary voltage or 2 copper protective pipes shall be provided and the heating lengths have to be connected in series.

$$\text{Heating capacity [Watt/m]: } N' = \frac{U^2}{R \cdot L^2}$$

U = supply voltage [Volt]  
R = resistance of heating cable [Ohm/m]  
L = length of heating section [m]

Type	Resistor <sup>(2)</sup>	Order- No.
heating cable: H 0,15	0,15 Ohm/m	196 382
heating cable: H 0,20	0,20 Ohm/m	196 383
heating cable: H 0,32	0,32 Ohm/m	196 384
heating cable: H 0,38	0,38 Ohm/m	196 385
heating cable: H 0,48	0,48 Ohm/m	196 386
heating cable: H 0,60	0,60 Ohm/m	196 387
heating cable: H 0,81	0,81 Ohm/m	196 389
heating cable: H 1,00	1,00 Ohm/m	196 390
heating cable: H 1,44	1,44 Ohm/m	196 391
heating cable: H 2,00	2,00 Ohm/m	196 392
heating cable: H 3,00	3,00 Ohm/m	196 393

**Composition of heating cable:** Conductor: material resistor CrNi, stranded  
Insulation: PTFE-(Teflon) tinned copper braid  
Sheath: PTFE-insulation  
OD: 3.7 mm - 4.3 mm Øm

Determine a heating cable of 30-45 watt/m capacity.

For longer runs, not covered by the adjacent diagrams, divide the length of the system into two or more heating sections.

Type	Order- No.
Copper Pipe 8 x 1 mm	
- for 40 - 200 A	195 289
- for 300 A	195 557
Connecting box for heating	
- for LSV	195 119
- for LSVG	184 027
Connecting material for heating system	195 291
(1 set per connecting box)	

## Layout of one heating section with feeder boxes at both ends

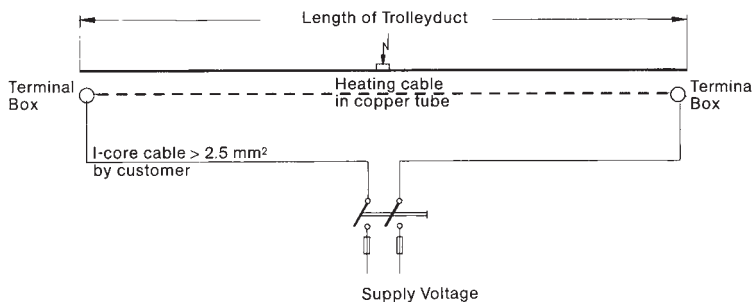

Switchgears and temperature control units available on request.

## Example for ordering heating system for 60 m trolleyduct

- 61 m heating cable type H 1.0 (60 m + 1 m safety length)  
Supply voltage 400 V, 1 heating section  
Heating capacity per above diagram approx. 40 W/m with 60 m x 40 W/m approx. 2400 W = 2.40 kW
- 60 m copper protection tube 8 x 1 mm factory assembled
- 2 terminal boxes for heating system
- 2 sets of connecting material

**All switches, fuses, cable etc. by others!**

(1) Factory assembled on powerail.  
(2) Deflection ± 2,5 %

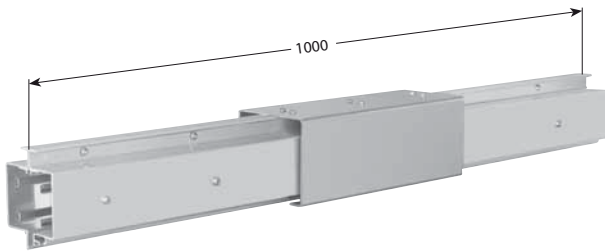

### Application of Anti-condensation section

This section consists of 1 m Powerail with openings covered by a protection hood.

The anti-condensation section will be used where Powerails are passing from indoor to outdoor, preventing the icing of the outside mounted Powerail as the warm air can escape and does not condensate in the Powerail.

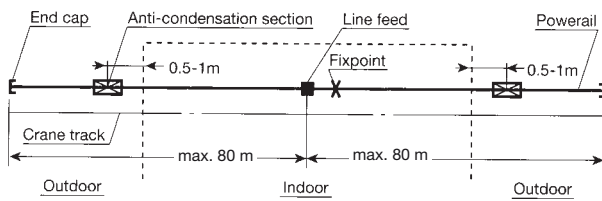

### Feeding

No extra feeds required as the Powerail is not interrupted.

### Collectors

No extra collectors required.

### Installation

The anti-condensation section will be placed directly at the transfer point from indoor to outdoor service..

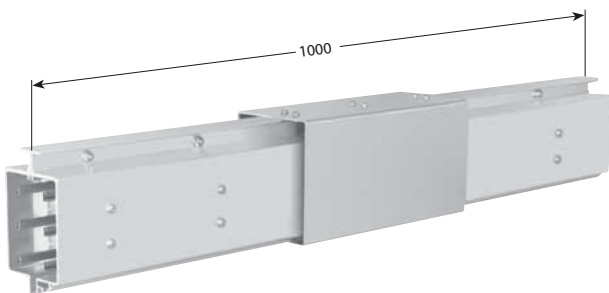

Type <sup>(2)</sup>	Order- No. Power line <b>HS</b> with PE	Order- No. Control line <b>SS</b> without PE
<b>BTL 4/ 60</b>	195 154	195 159
<b>BTL 4/100</b>	195 155	–
<b>BTL 4/140</b>	195 156	–
<b>BTL 4/200</b>	195 157	–
<b>BTL 4/300</b>	195 158	–
<b>BTL 5/•60</b>	195 160	–
<b>BTL 5/100</b>	195 161	–
<b>BTL 5/140</b>	195 162	–
<b>BTL 5/200</b>	195 163	–
<b>BTL 5/300</b>	195 164	–
<b>BTL 6/ 60</b>	195 165	195 168
<b>BTL 6/100</b>	195 166	–
<b>BTL 6/140</b>	195 167	–
<b>BTL 6/200</b>	195 622	–
<b>BTL 7/ 60</b>	195 169	–
<b>BTL 7/100</b>	195 170	–
<b>BTL 7/140</b>	195 171	–
<b>BTL 7/200</b>	195 623	–

Type <sup>(2)</sup>	Order- No. Power line <b>HS</b> with PE	Order- No. Control line <b>SS</b> without PE
<b>BTLG 6/ 60</b>	184 049	184 073
<b>BTLG 6/100</b>	184 050	–
<b>BTLG 6/140</b>	184 051	–
<b>BTLG 6/200</b>	184 052	–
<b>BTLG 6/300</b>	184 053	–
<b>BTLG 7/ 60</b>	184 054	–
<b>BTLG 7/100</b>	184 055	–
<b>BTLG 7/140</b>	184 056	–
<b>BTLG 7/200</b>	184 057	–
<b>BTLG 7/300</b>	184 058	–
<b>BTLG 8/ 60</b>	184 059	184 062
<b>BTLG 8/100</b>	184 060	–
<b>BTLG 8/140</b>	184 061	–
<b>BTLG 8/200</b>	184 644	–
<b>BTLG 9/ 60</b>	184 063	–
<b>BTLG 9/100</b>	184 064	–
<b>BTLG 9/140</b>	184 065	–
<b>BTLG 9/200</b>	184 645	–
<b>BTLG 10/ 60</b>	184 066	184 069
<b>BTLG 10/100</b>	184 067	–
<b>BTLG 10/140</b>	184 068	–
<b>BTLG 10/200</b>	184 646	–
<b>BTLG 11/ 60</b>	184 070	–
<b>BTLG 11/100</b>	184 071	–
<b>BTLG 11/140</b>	184 072	–
<b>BTLG 11/200</b>	184 647	–

<sup>(1)</sup> Above sections come ready assembled on 1 m Powerail and are a part of the system length (see example for ordering page 27).

<sup>(2)</sup> Suffix types e.g. BTL 4/60 w/ PE → BTL 4/60 L **HS** Order- No. 195 154.



# TELESCOPE SECTIONS<sup>(1)</sup>

## € / w 1 m Powerail

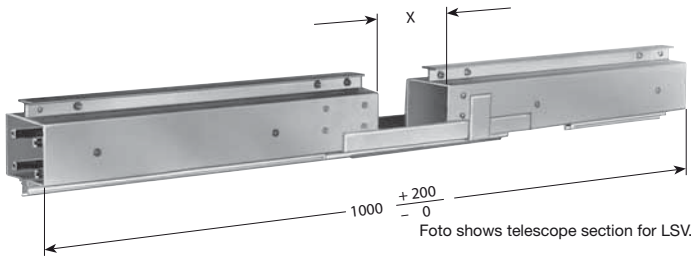

The 1 m telescope sections of the Aluminium enclosed conductor rails LSV and LSVG cover the expansion of the housing in temperature fluctuation.

They consist of two transfer guides, which are aligned through two profiles. The connecting profile pieces serve as running and guiding track for the current collector. The telescope section separates the track electrically. For spare parts please advise type of rail and possible special versions.

LSV				LSVG					
Type ●	Order- No.	Type ●	Order- No.	Type ●	Order- No.	Type ●	Order- No.	Type ●	Order- No.
Power line HS with PE		Power line HS with PE		Power line HS with PE		Power line HS with PE		Power line HS with PE	
TSL 4/ 60	193 840	TSL 6/ 60	193 940	TSLG 6/ 60	183 310	TSLG 8/ 60	183 410	TSLG 11/ 60	183 500
TSL 4/100	195 096	TSL 6/100	195 104	TSLG 6/100	184 001	TSLG 8/100	184 009	TSLG 11/100	184 015
TSL 4/140	195 097	TSL 6/140	195 105	TSLG 6/140	184 002	TSLG 8/140	184 010	TSLG 11/140	184 016
TSL 4/200	195 098	TSL 6/200	195 624	TSLG 6/200	184 003	TSLG 8/200	184 648	TSLG 11/200	184 651
TSL 4/300	195 099			TSLG 6/300	184 004	TSLG 9/ 60	183 440	Control line SS without PE	
		TSL 7/ 60	193 970			TSLG 9/100	184 011	TSLG 6/ 60	183 530
TSL 5/ 60	193 890	TSL 7/100	195 106	TSLG 7/ 60	183 360	TSLG 9/140	184 012	TSLG 8/ 60	183 540
TSL 5/100	195 100	TSL 7/140	195 107	TSLG 7/100	184 005	TSLG 9/200	184 649	TSLG 10/ 60	183 550
TSL 5/140	195 101	TSL 7/200	195 625	TSLG 7/140	184 006	TSLG 10/ 60	183 470		
TSL 5/200	195 102	Control line SS without PE		TSLG 7/200	184 007	TSLG 10/100	184 013		
TSL 5/300	195 103	TSL 4/ 60	194 000	TSLG 7/300	184 008	TSLG 10/140	184 014		
		TSL 6/ 60	194 010			TSLG 10/200	184 650		

### Application of Telescope section

- For Powerail lengths exceeding 160 m (see Fig. 1).
- For passing the Powerail from indoor to outdoor, thus preventing the icing of the outside mounted Powerail, as the warm air can escape and does not condensate in the Powerail (see Fig. 2). – Alternative solution: Anti-condensation section (see page 17). We recommend a heating system for the outdoor section for extreme winter conditions (see page 16).
- If the Powerail length between two curves is more than 30 m and the temperature fluctuates considerably (see Fig. 3).

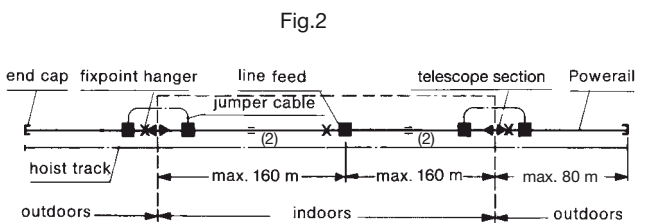
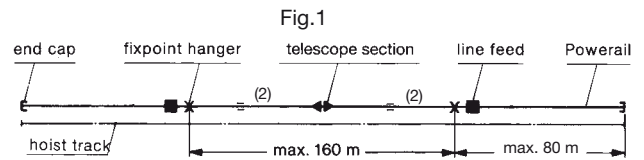

### Feeding

The Powerail is electrically separated into two parts by the telescope section. Each of these parts has to have a separate power feed. In case of transfers to outdoor the main feed can be inside. In this case will be connecting boxes on the left and right hand side of the telescope section installed. This boxes are connected by flexible cables. (see fig. 2).

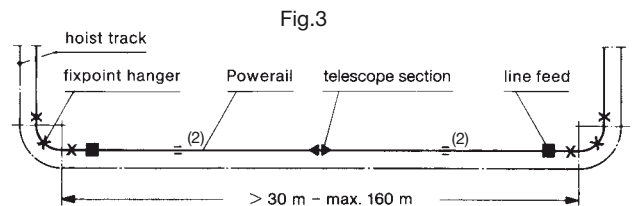

### Collectors

One double collector, installed at least 500 mm apart, must be used to ensure continuous electrical contact while passing through the telescope section; use two double collectors arranged in the same manner when higher ampacity is required.

(1) Above sections come ready assembled on 1 m Powerail and are a part of the system length.  
 (2) DSL/DSLГ with bolted joints only see page 19.  
 ● Suffix types e.g. TSL 4/60 w/ PE → TSL 4/60 HS Order- No. 193 840.

# EXPANSION JOINT SECTIONS<sup>(1)</sup>

c/w 1 m Powerail

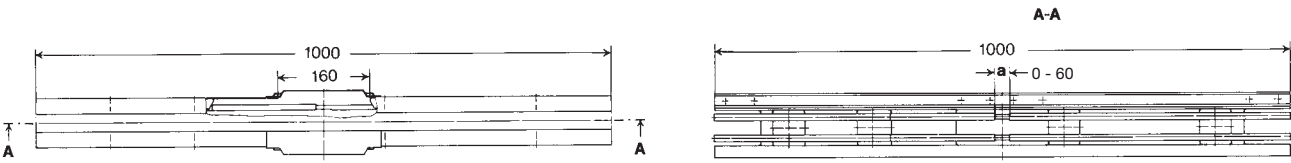

Drawings show expansion joint section for LSV

LSV				LSVG					
Type ●	Order- No.	Type ●	Order- No.	Type ●	Order- No.	Type ●	Order- No.	Type ●	Order- No.
Power line HS with PE		Power line HS with PE		Power line HS with PE		Power line HS with PE		Power line HS with PE	
DSL 4/ 60	194 020	DSL 6/ 60	194 120	DSL 6/ 60	183 560	DSL 8/ 60	183 660	DSL 11/ 60	183 750
DSL 4/100	195 108	DSL 6/100	195 112	DSL 6/100	184 017	DSL 8/100	184 021	DSL 11/100	184 024
DSL 4/140	195 056	DSL 6/140	195 058	DSL 6/140	183 943	DSL 8/140	183 945	DSL 11/140	183 948
DSL 4/200	195 109	DSL 6/200	195 626	DSL 6/200	184 018	DSL 8/200	184 652	DSL 11/200	184 655
DSL 4/300	194 060			DSL 6/300	183 600				
		DSL 7/ 60	194 150			DSL 9/ 60	183 690	Control line SS without PE	
		DSL 7/100	195 113	DSL 7/ 60	183 610	DSL 9/100	184 022		
DSL 5/ 60	194 070	DSL 7/140	195 059	DSL 7/100	184 019	DSL 9/140	183 946	DSL 6/ 60	183 780
DSL 5/100	195 110	DSL 7/200	195 627	DSL 7/140	183 944	DSL 9/200	184 653	DSL 8/ 60	183 790
DSL 5/140	195 057			DSL 7/200	184 020	DSL 10/ 60	183 720	DSL 10/ 60	183 800
DSL 5/200	195 111	Control line SS without PE		DSL 7/300	183 650	DSL 10/100	184 023		
DSL 5/300	194 110	DSL 4/ 60	194 180			DSL 10/140	183 947		
		DSL 6/ 60	194 190			DSL 10/200	184 654		

The expansion joints of the VAHLE aluminium enclosed conductor systems LSV and LSVG serve to compensate for the different expansion and contraction of the aluminium housing and the copper conductors in varying temperatures.

**Expansion joints are only required for LSV and LSVG-systems using bolted joints.**

Systems using **plug-in type connections** (Standard 60-140 A) are sliding inside the hollow conductors and automatically take care of this. The copper conductors are being anchored in each standard powerail section.

Expansion joints will be installed between **two fixpoints** of the **copper conductors** with a distance >10 m. The max. length "L" mm has to be considered accordingly.

**Design fixpoints** are feedings, dead sections, transfer guides, transfer funnels and telescope sections (see sketch 1).

**Additional fixpoints** for copper conductors will be installed if the lengths between design fixpoints exceed the max. length "L". Then are two or more expansion joints necessary. (see sketch 2 and example on page 27).

The expansion of the aluminium housing will not be affected through the fixpoints of the copper conductors.

The fixpoint hangers of the aluminium housing will be installed in the middle of the system or close to the feed point. Transfer guide and transfer funnel.

The remaining conductor sections **have to be** arranged in sliding hangers.

In special cases the connecting cables at the line feeds have to be arranged flexible. Or the types LAL and or LALG (see page 11) have to be used not to interfere the expansion of the housing.

In the expansion section are the copper conductors electrically bridged.

Fig. 1

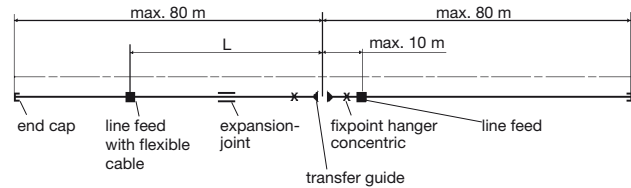
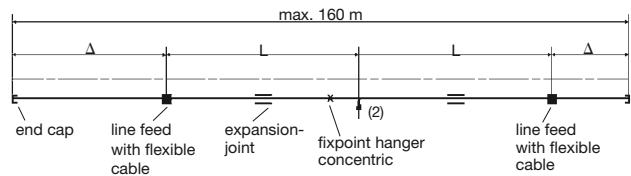

Fig. 2



Δ Excessive length

Max. length „L“:

**80 m** at temperature up to **60 °C**

**60 m** at temperature up to **80 °C**

**40 m** at temperature up to **100 °C**

All valves apply from **- 40 °C**

Please send us the filled in Questionnaire from pages 29 and 30 and you will receive a layout drawing.

For spare please advise rail type and possible special version.

Anchor points for copper conductors ( <sup>(2)</sup> q)					
LSV			LSVG		
Type	No. of cond.	Order- No.	Typ	No. of cond.	Order- No.
FPL/Cu	4 & 5	194 530	FPLG/Cu	6 & 7	183 830
FPL/Cu	6 & 7	194 540	FPLG/Cu	8 & 9	183 840
			FPLG/Cu	10 & 11	183 850

<sup>(1)</sup> Above sections come ready assembled on 1 m Powerail and are a part of the system length (see example for ordering page 27).

● Suffix types e.g. DSL 4/60 w/ PE → DSL 4/60 L HS Order- No. 194 020.



# COLLECTORS

## LSV

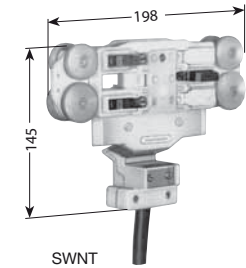
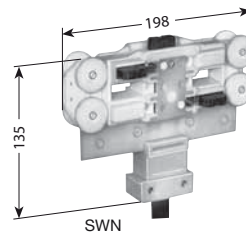

	Type <sup>(2)</sup>	A <sup>(1)</sup>	Order- No.	Type <sup>(2)</sup>	A <sup>(1)</sup>	Order- No.	Poles	Weight kg	max. speed m/min.		General
	for Power <b>HS</b> with PE			for Control <b>ST</b> without PE				nor-	trans-		
LSV	<b>SWK 4/25-1</b>	25	250 230	<b>SWK 4/25-1</b>	25	250 240	4	0,760	80	60	for straight runs and curves R > 2.5 m for LSV 4/60 and LSV 4/100
	<b>SWK 4/40-1</b>	40	257 394	–	–	–	4	0,860	80	60	
	<b>SWN 4/40-1</b>	40	194 691	<b>SWN 4/25-1</b>	25	194 692	4	0,850	180	80	for straight runs and curves R > 1.5 m with ball bearing wheels
	<b>SWN 5/40-1</b>	40	194 693				5	0,950	180	80	
	<b>SWN 6/40-1</b>	40	194 694	<b>SWN 6/25-1</b>	25	194 695	6	1,200	180	80	
	<b>SWN 7/40-1</b>	40	194 696				7	1,300	180	80	
LSV with Kurven	<b>SWN 4/40 K-1</b>	40	195 197	<b>SWN 4/25 K-1</b>	25	195 194	4	0,830	180	80	for curves R 0.75 – 1.5 m ball bearing wheels
	<b>SWN 5/40 K-1</b>	40	195 196				5	0,930	180	80	
	<b>SWN 6/40 K-1</b>	40	196 171	<b>SWN 6/25 K-1</b>	25	195 195	6	1,180	180	80	
	<b>SWN 7/40 K-1</b>	40	195 987				7	1,280	180	80	
LSV+D or FP	<b>SWNT 4/40-1</b>	40	194 772	<b>SWNT 4/25-1</b>	25	194 773	4	0,850	100	60	for straight runs and curves R > 1.0 m with ball bearing wheels
	<b>SWNT 5/40-1</b>	40	194 774				5	0,950	100	60	
	<b>SWNT 6/40-1</b>	40	194 775	<b>SWNT 6/25-1</b>	25	194 776	6	1,200	100	60	
	<b>SWNT 7/40-1</b>	40	194 777				7	1,300	100	60	

Trolley connecting cable 1 m long (longer cable available); copper cross section 2.5 mm<sup>2</sup> per core for 25 A and 4 mm<sup>2</sup> per core for 40 A.

Cleaning trolleys and trolleys for higher speed on request.

## LSVG

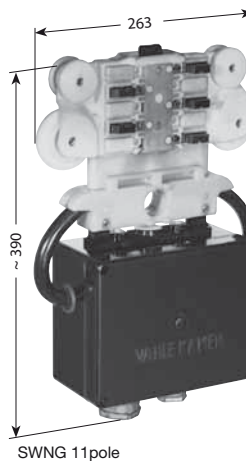
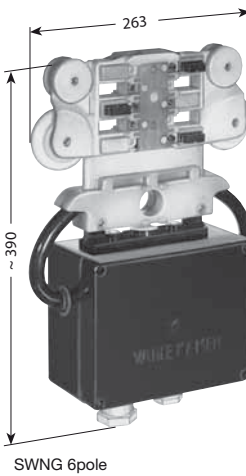

	Type <sup>(2)</sup>	A <sup>(1)</sup>	Order- No.	Type <sup>(2)</sup>	A <sup>(1)</sup>	Order- No.	Poles	Weight kg	max. speed m/min.		General
	Hauptstrom <b>HS</b> mit PE			Steuerstrom <b>ST</b> ohne PE				nor-	trans-		
LSVG	<b>SWNG 6/40</b>	40	183 883	<b>SWNG 6/25</b>	25	183 884	6	2,100	200	100	for straight runs and curves with ball bearing wheels and guide rollers
	<b>SWNG 7/40</b>	40	183 885				7	2,150	200	100	
	<b>SWNG 8/40</b>	40	183 886	<b>SWNG 8/25</b>	25	183 887	8	2,200	200	100	
	<b>SWNG 9/40</b>	40	183 888				9	2,250	200	100	
	<b>SWNG 10/40</b>	40	183 889	<b>SWNG 10/25</b>	25	183 890	10	2,300	200	100	
	<b>SWNG 11/40</b>	40	183 891				11	2,350	200	100	
LSVG	<b>SWNG 6/40 FM</b>	40	183 901	<b>SWNG 6/25 FM</b>	25	183 902	6	2,100	200	80	like above however, for transfer applications
	<b>SWNG 7/40 FM</b>	40	183 903				7	2,150	200	80	
	<b>SWNG 8/40 FM</b>	40	183 904	<b>SWNG 8/25 FM</b>	25	183 905	8	2,200	200	80	
	<b>SWNG 9/40 FM</b>	40	183 906				9	2,250	200	80	
	<b>SWNG 10/40 FM</b>	40	183 907	<b>SWNG 10/25 FM</b>	25	183 908	10	2,300	200	80	
	<b>SWNG 11/40 FM</b>	40	183 909				11	2,350	200	80	
LSVG mit D+FP	<b>SWNGT 6/40</b>	40	183 892	<b>SWNGT 6/25</b>	25	183 893	6	2,100	100	60	for straight runs and curves with ball bearing wheels and guide rollers
	<b>SWNGT 7/40</b>	40	183 894				7	2,150	100	60	
	<b>SWNGT 8/40</b>	40	183 895	<b>SWNGT 8/25</b>	25	183 896	8	2,200	100	60	
	<b>SWNGT 9/40</b>	40	183 897				9	2,250	100	60	
	<b>SWNGT 10/40</b>	40	183 898	<b>SWNGT 10/25</b>	25	183 899	10	2,300	100	60	
	<b>SWNGT 11/40</b>	40	183 900				11	2,350	100	60	

Collectors come with terminal box and each with 1 x M 32 and 1 x M 25.

Collectors and terminal boxes are wired.

Cross section: collector 25 A – 2,5 mm<sup>2</sup>  
collector 40 A – 4 mm<sup>2</sup>

Cleaning trolleys on request.

(1) All ampere data for 60 % intermittent duty.

(2) For full Type designation add Power or Control, suffix e.g. SWK 4/25-1 w/ PE  
SWNG 6/25 w/o PE

**HS** for Order- No. 250 230

**ST** for Order- No. 183 884.

# DOUBLE COLLECTORS



LSV

**F** = flexible strap connection for curves  
**S** = rigid bar connection for straight runs

Type <sup>(2)</sup>	A <sup>(1)</sup>	Order- No.	Type <sup>(2)</sup>	A <sup>(1)</sup>	Order- No.	Poles	Weight kg
for Power <b>HS</b> with PE			for Control <b>ST</b> without PE				
<b>LSV</b>							
<b>DSWK 4/50 F-1</b>	50	250 320	<b>DSWK 4/50 F-1</b>	50	250 330	4	1,900
<b>DSWK 4/80 F-1</b>	80	252 580	–	–	–	4	2,100
<b>DSWK 4/50 S-1</b>	50	258 383	<b>DSWK 4/50 S-1</b>	50	258 384	4	1,900
<b>DSWK 4/80 S-1</b>	80	252 590	–	–	–	4	2,100
<b>DSWN 4/80 F-1</b>	80	194 703	<b>DSWN 4/50 F-1</b>	50	194 704	4	2,150
<b>DSWN 5/80 F-1</b>	80	194 705	–	–	–	5	2,350
<b>DSWN 6/80 F-1</b>	80	194 706	<b>DSWN 6/50 F-1</b>	50	194 707	6	3,000
<b>DSWN 7/80 F-1</b>	80	194 708	–	–	–	7	3,250
<b>DSWN 4/80 S-1</b>	80	194 808	<b>DSWN 4/50 S-1</b>	50	194 809	4	2,150
<b>DSWN 5/80 S-1</b>	80	194 810	–	–	–	5	2,350
<b>DSWN 6/80 S-1</b>	80	194 811	<b>DSWN 6/50 S-1</b>	50	194 812	6	3,000
<b>DSWN 7/80 S-1</b>	80	194 813	–	–	–	7	3,250
<b>LSV + D or FP</b>							
<b>DSWNT 4/80 F-1</b>	80	194 778	<b>DSWNT 4/50 F-1</b>	50	194 779	4	2,150
<b>DSWNT 5/80 F-1</b>	80	194 780	–	–	–	5	2,350
<b>DSWNT 6/80 F-1</b>	80	194 781	<b>DSWNT 6/50 F-1</b>	50	194 782	6	3,000
<b>DSWNT 7/80 F-1</b>	80	194 783	–	–	–	7	3,250
<b>DSWNT 4/80 S-1</b>	80	194 814	<b>DSWNT 4/50 S-1</b>	50	194 815	4	2,150
<b>DSWNT 5/80 S-1</b>	80	194 816	–	–	–	5	2,350
<b>DSWNT 6/80 S-1</b>	80	194 817	<b>DSWNT 6/50 S-1</b>	50	194 818	6	3,000
<b>DSWNT 7/80 S-1</b>	80	194 819	–	–	–	7	3,250

Double collector for 50 A with cross section 2 x 2,5 mm<sup>2</sup>.

Double collector for 80 A with cross section 2 x 4 mm<sup>2</sup>.

Connecting cable 1 m long, longer cable available.

Don't use double collectors, but 2 singles for curves with less than 1.5 m radius and for transfer guides more than 45 degr. oblique cut.

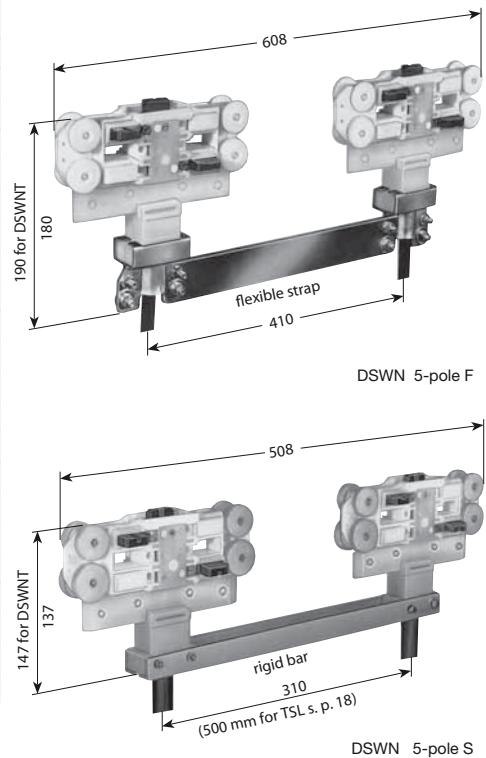

LSVG

Type <sup>(2)</sup>	A <sup>(1)</sup>	Order- No.	Type <sup>(2)</sup>	A <sup>(1)</sup>	Order- No.	Poles	Weight kg	
for Power <b>HS</b> with PE			for Control <b>ST</b> without PE					
<b>LSVG</b>	<b>DSWNG 6/80</b>	80	183 910	<b>DSWNG 6/50</b>	50	183 911	6	4,150
	<b>DSWNG 7/80</b>	80	183 912				7	4,250
	<b>DSWNG 8/80</b>	80	183 913	<b>DSWNG 8/50</b>	50	183 914	8	4,350
	<b>DSWNG 9/80</b>	80	183 915				9	4,450
	<b>DSWNG 10/80</b>	80	183 916	<b>DSWNG 10/50</b>	50	183 917	10	4,550
	<b>DSWNG 11/80</b>	80	183 918				11	4,650
<b>LSVG with D + FP</b>	<b>DSWNGT 6/80</b>	80	183 919	<b>DSWNGT 6/50</b>	50	183 920	6	4,150
	<b>DSWNGT 7/80</b>	80	183 921				7	4,250
	<b>DSWNGT 8/80</b>	80	183 922	<b>DSWNGT 8/50</b>	50	183 923	8	4,350
	<b>DSWNGT 9/80</b>	80	183 924				9	4,450
	<b>DSWNGT 10/80</b>	80	183 925	<b>DSWNGT 10/50</b>	50	183 926	10	4,550
	<b>DSWNGT 11/80</b>	80	183 927				11	4,650

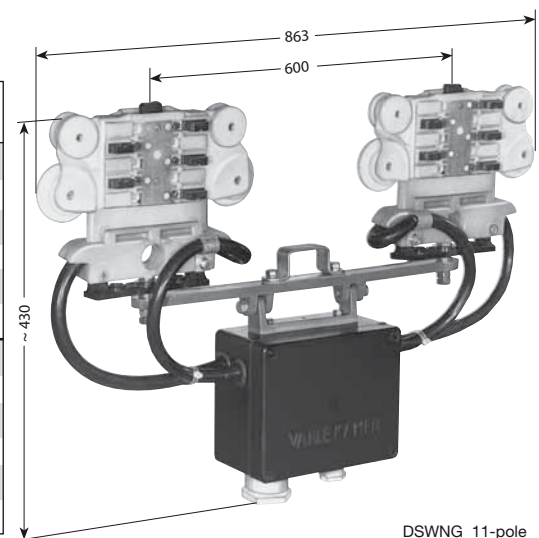

Double collectors come with terminal boxes.

Power line: je 1 x M 50 and 1 x M 25

Control line: je 1 x M 32 and 1 x M 25

Collectors and terminal boxes are wired.

Cross section: double collector 50 A – 2 x 2,5 mm<sup>2</sup>  
 double collector 80 A – 2 x 4 mm<sup>2</sup>

<sup>(1)</sup> All ampere data for 60 % intermittent duty.

<sup>(2)</sup> For full Type designation add Power or Control, suffix e.g. DSWK 4/50 F-1 **HS** for Order- No. 250 320  
 DSWNG 6/50 **ST** for Order- No. 183 911.



# TOW ARMS

LSV

for single and double collector

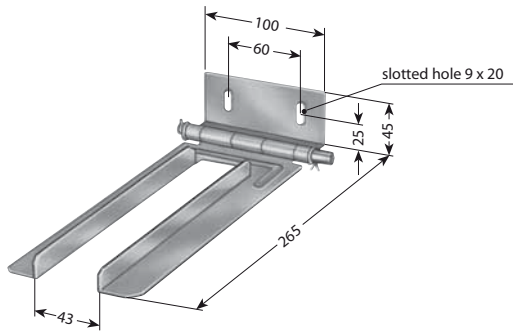

Type	Weight kg	Order- No.
<b>KWS</b>	0,480	250 380
<b>KWS/K<sup>(1)</sup></b>	0,480	252 340

flexible support type with single collector  
for tranfer funnel ETL; see pages 13 & 23

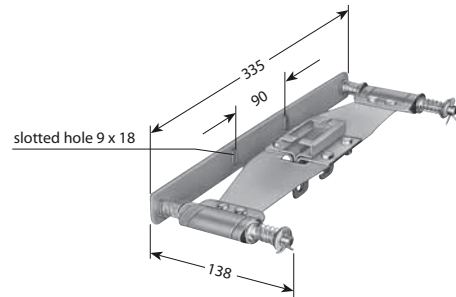

If you are going to use the flexible towing arm in system with curves please contact us.

Type	Weight kg	Order- No.
<b>KFMN</b> for SWK	1,160	259 515
<b>KFMLN</b> for SWN and SWNT	1,170	259 506

LSVG

for single and double collector

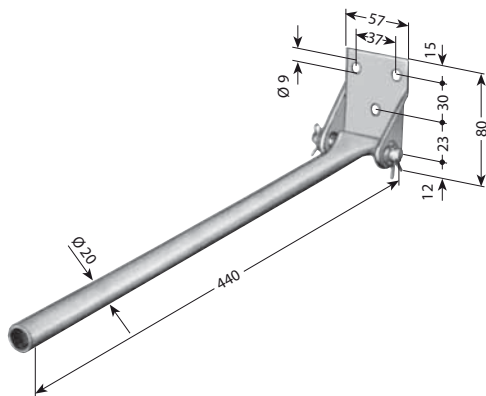

Type	Weight kg	Order- No.
<b>GKM</b>	0,620	260 350
<b>GKM/K<sup>(1)</sup></b>	0,620	261 560

flexible support type with single collector  
for tranfer funnel ETLG; see pages 13 & 23

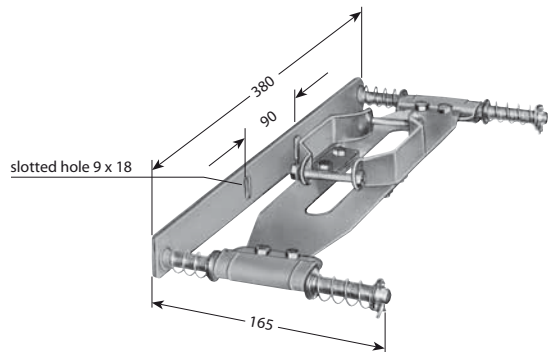

Type	Weight kg	Order- No.
<b>GFMN</b> for SWNG/FM	1,300	185 547

# FLEXIBLE TOW ARM CONFIGURATIONS



LSV

SWN 5/40 collector and KFML tow arm

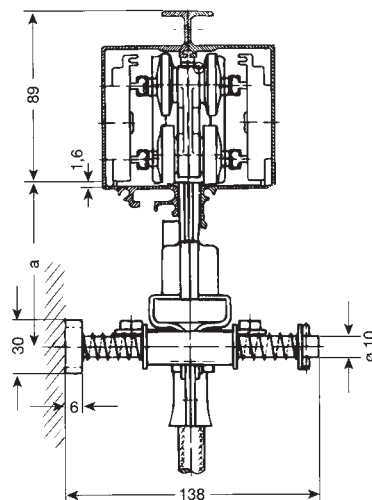
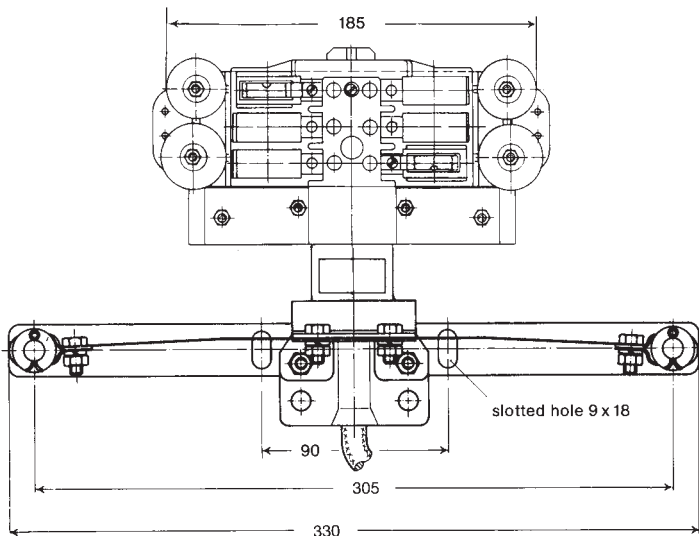

max. horizontal offset 15 mm  
max. vertical offset 10 mm

with collector	SWK	SWN	SWNT
Dim. a	85	95	105

SWNG 11/40 FM collector and GFM tow arm

LSVG

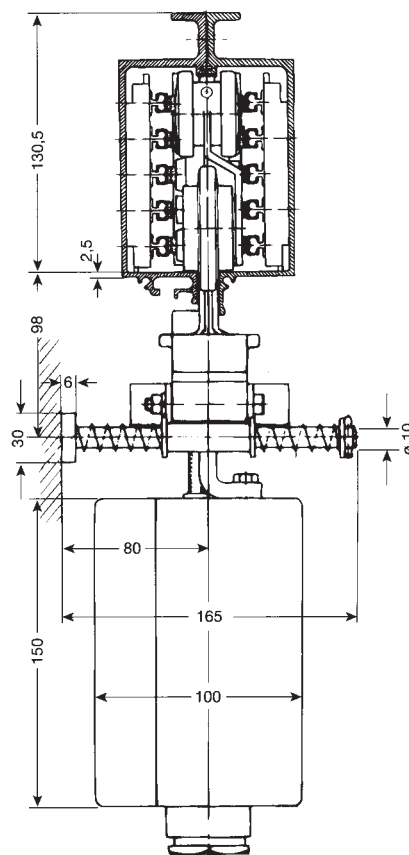
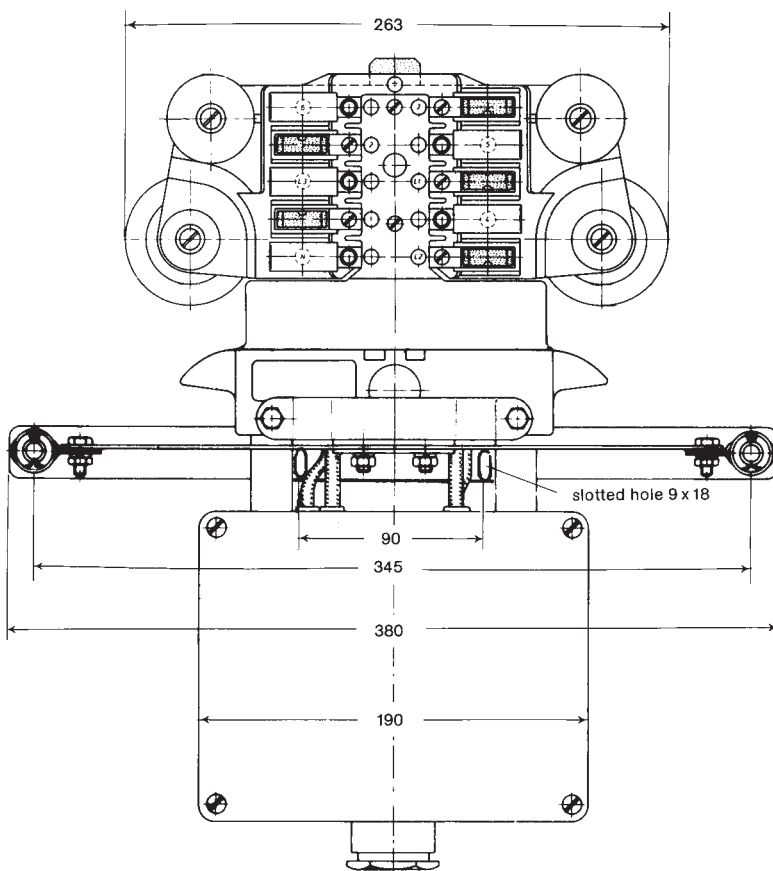

max. horizontal offset 15 mm  
max. vertical offset 10 mm

(1) adjust during installation



# SPARE PARTS

# SECTIONALIZING

LSV

	Order-No.
<b>for Powerail</b>	
joint fish plate (stainless), pair	191 830
joint cover, pair	191 840
joint cover anodized, pair	190 470
peg to fix housing	190 510
copper conductor 16 mm <sup>2</sup> , 5th and 7th pole (top)	195 190
copper conductor rail 16 mm <sup>2</sup> (lateral)	191 880
copper conductor rail 25 mm <sup>2</sup> (lateral)	191 900
copper conductor rail 35 mm <sup>2</sup> (lateral)	191 910
copper conductor rail 50 mm <sup>2</sup> (lateral)	191 920
copper conductor rail 50 mm <sup>2</sup> (lateral for ground 300 A only)	201 170
copper conductor rail 70 mm <sup>2</sup> (lateral for Phase 300 A only)	191 930
2pole insulator for 60-200 A systems	195 699
2pole insulator for 300 A systems	195 700
3pole insulator for 60-200 A systems	195 701
plug-in connector for 60-140 A systems	191 800
bolted joint connector for 60-200 A systems (for 200 A only)	191 810
bolted joint connector for 300 A systems	191 820
locking pin for plastic shielding	280 500
coupling for sealing strip	258 300
fastener for sealing strip	258 432
mounting trolley for sealing strip	258 345

for Collectors	Type	SWK <sup>(1)</sup>	SWN	SWNT
		Order- No.	Order- No.	Order- No.
carbon brush phase, incl. brush holder (lateral)		250 470	254 890	254 890
carbon brush ground 5th and 7th pole (top), incl. brush holder		-	254 891	254 891
carbon brush ground, incl. brush holder (lateral)		250 480	254 892	254 892
carbon pressure spring		250 490	258 757	258 757
carbon pressure spring, reinforced		258 759	258 760	258 760
collector neck (pair)		-	254 893	254 898
glider plate for sealing strip		-	-	258 370
wheel (bottom)		251 690	254 895	254 895
guide roller (top)		251 700	254 903	254 903
connecting strap for double collectors		258 379	258 379	258 379
connecting bar for double collectors		258 430	258 431	258 431
attachment clamp KWZ		250 310	-	-
attachment clamp KWZ/K, stainless		252 639	-	-
attachment clamp KWZL		-	254 897	254 897

## Conductor dead section<sup>(2)</sup>

factory assembled  
(300 Amp. systems with air gap only)

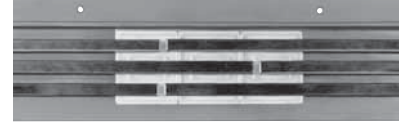

Illustration shows STA 3

Type	with air gap 5 mm Order- No.	Type	with insul. section 30 mm Order- No.
STA 1	193 440	STI 1	193 500
STA 2	193 450	STI 2	193 510
STA 3	193 460	STI 3	193 520
STA 4	193 470	STI 4	193 530
STA 5	193 480	STI 5	193 540
STA 6	193 490	STI 6	193 550

LSVG

	Order- No.
<b>for Powerail</b>	
joint fish plate (stainless), pair	183 060
joint cover, pair	183 080
joint cover anodized, pair	183 090
peg to fix housing	190 510
copper conductor rail 16 mm <sup>2</sup> (lateral)	191 880
copper conductor 16 mm <sup>2</sup> , 7th, 9th and 11th pole (top)	195 190
copper conductor rail 25 mm <sup>2</sup> (lateral)	191 900
copper conductor rail 35 mm <sup>2</sup> (lateral)	191 910
copper conductor rail 50 mm <sup>2</sup> (lateral)	191 920
copper conductor rail 50 mm <sup>2</sup> (lateral for PE 300 A only)	201 170
copper conductor rail 70 mm <sup>2</sup> (lateral)	191 930
5pole insulator for 60-200 A systems	184 812
2pole insulator for 300 A systems	195 700
plug-in connector for 60-140 A systems	191 800
bolted joint connector for 60-200 A systems	191 810
bolted joint connector for 300 A systems	191 820
locking pin for plastic shielding	280 500
coupling for sealing strip	258 300
fastener for sealing strip	258 432
mounting trolley for sealing strip	184 033

for Collectors	Typ	SWNG	SWNGT
		Order- No.	Order- No.
carbon brush phase, incl. brush holder (lateral)		254 890	254 890
carbon brush ground 7th, 9th and 11th pole (top)		254 891	254 891
carbon brush ground, incl. brush holder (lateral)		254 892	254 892
carbon pressure spring		258 757	258 757
carbon pressure spring, reinforced		258 760	258 760
collector neck (pair)		183 280	183 865
wheel (bottom)		183 290	183 290
guide roller (top)		183 300	183 300

## Conductor dead section<sup>(2)</sup>

factory assembled  
(300 Amp. systems with air gap only)

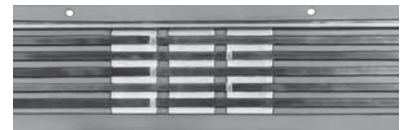

Illustration shows STAG 5

Type	with air gap 5 mm Order- No.	Type	with insul. section 30 mm Order- No.
STAG 1	182 860	STIG 1	182 960
STAG 2	182 870	STIG 2	182 970
STAG 3	182 880	STIG 3	182 980
STAG 4	182 890	STIG 4	182 990
STAG 5	182 900	STIG 5	183 000
STAG 6	182 910	STIG 6	183 010
STAG 7	182 920	STIG 7	183 020
STAG 8	182 930	STIG 8	183 030
STAG 9	182 940	STIG 9	183 040
STAG 10	182 950	STIG 10	183 050

<sup>(1)</sup> SWK carbon brush without brush holder.

<sup>(2)</sup> Please indicate which conductors are to be interrupted.



Aluminium enclosed conductor system for crane electrifications.



Aluminium enclosed conductor system LSVG on crane bridge.



# EXAMPLES FOR ORDERING

## with Plug-in joints

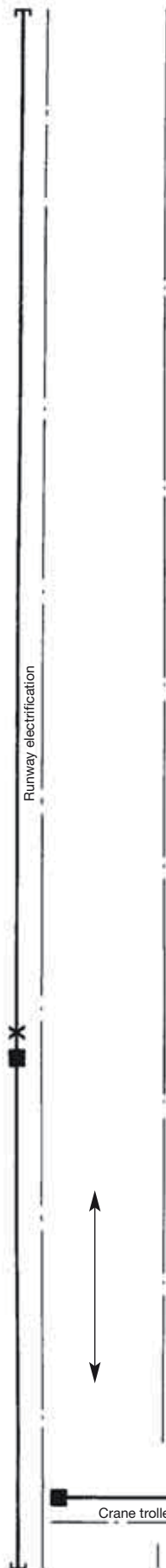

### Runway electrification · 40 m

Qty		Type	Order- No.	Type	Order- No.
9	Powerails, 4 m long	LSV 4/60-4 <b>HS</b>	190 004	LSVG 10/60-4 <b>HS</b>	180 164
1	Powerail, 3 m long	LSV 4/60-3 <b>HS</b>	190 003	LSVG 10/60-3 <b>HS</b>	180 163
1	Line feed, 1 m long	NKL 4/60 <b>HS</b>	195 074	NKLG 10/60 <b>HS</b>	185 057
10	Joint materials	VBL 4/5	195 244	VLG 10/11	184 111
19	Sliding hangers	GAL	190 130	SAS	200 160
1	Fixpoint hanger	FAL	190 120	SAFG	180 310
2	End caps	EKL	190 220	EKLG	180 320
1	Double collector	DSWN 4/80 S-1 <b>HS</b>	194 808	DSWNG 10/80 <b>HS</b>	183 916
1	Tow arm	KWS	250 380	GKM	260 350

### Crane trolley electrification · 12 m

2	Powerails, 4 m long	LSV 7/60-4 <b>HS</b>	190 074	LSVG 11/60-4 <b>HS</b>	180 194
1	Powerail, 3 m long (cut in 2.5 m)	LSV 7/60-3 <b>HS</b>	190 073	LSVG 11/60-3 <b>HS</b>	180 193
1	End feed, 1 m long	KEL 7/60 R <b>HS</b>	190 170	KELG 11/60 R <b>HS</b>	180 480
4	Joint materials	VBL 6/7	195 246	VLG 10/11	184 111
5	Sliding hangers	GAL	190 130	SAS	200 160
1	Fixpoint hanger	FAL	190 120	SAFG	180 310
1	Transfer guide, 0.5 m long	AÜL 7/60 L <b>HS</b>	192 450	AÜLG 11/60 L <b>HS</b>	181 350
1	Double collector	DSWN 7/80 S-1 <b>HS</b>	194 813	DSWNG 11/80 <b>HS</b>	183 918
1	Tow arm	KWS	250 380	GKM	260 350

### Spur rail electrification · 30 m

7	Powerails, 4 m long	LSV 7/60-4 <b>HS</b>	190 074	LSVG 11/60-4 <b>HS</b>	180 194
1	Powerail, 1 m long (cut in 0.5 m)	LSV 7/60-1 <b>HS</b>	190 071	LSVG 11/60-1 <b>HS</b>	180 191
9	Joint materials	VBL 6/7	195 246	VLG 10/11	184 111
14	Sliding hangers	GAL	190 130	SAS	200 160
1	Fixpoint hanger	FAL	190 120	SAFG	180 310
1	Line feed, 1 m long	NKL 7/60 <b>HS</b>	195 089	NKLG 11/60 <b>HS</b>	183 992
1	Transfer guide, 0.5 m long	AÜL 7/60 R <b>HS</b>	192 460	AÜLG 11/60 R <b>HS</b>	181 360
1	End cap	EKL	190 220	EKLG	180 320

X = Fixpoint hanger; all other support points are sliding hangers.

Sealing strip "D" and plastic shielding "FP" have to be ordered separately with the corresponding collectors (see pages 6 and 20). Heating system may be provided. (see page 16).



## Straight track electrification · 277 m · with Line feed and Bolted joints

Anticipated max. temperature 60° C, L = max. 80 m;  
277m total length of the system consisting of:

Qty		Type	Order- No.	Type	Order- No.
68	Powerails, 4 m long	LSV 4/200-4 <b>HS</b>	190 614	LSVG 6/200-4 <b>HS</b>	180 034
1	Line feed, 1 m long	NKL 4/200 <b>HS</b>	195 077	NKLG 6/200 <b>HS</b>	185 031
2	Expansion joint sections, 1 m long	DSL 4/200 <b>HS</b>	195 109	DSL6 6/200 <b>HS</b>	184 018
1	Telescope section	TSL 4/200 <b>HS</b>	195 098	TSLG 6/200 <b>HS</b>	184 003
72	Joint materials	VBLS 4/5	195 248	VLGS 6/7	184 113
1	Fixpoint hanger	FAL	190 120	SAFG	180 310
139	Sliding hangers	GAL	190 130	SAS	200 160
2	End caps	EKLS	195 149	EKLG	184 100
2	Double collectors	DSWN 4/80 S-1 <b>HS</b>	194 808	DSWNG 6/80 <b>HS</b>	183 910
2	Tow arms	KWS	250 380	GKM	260 350

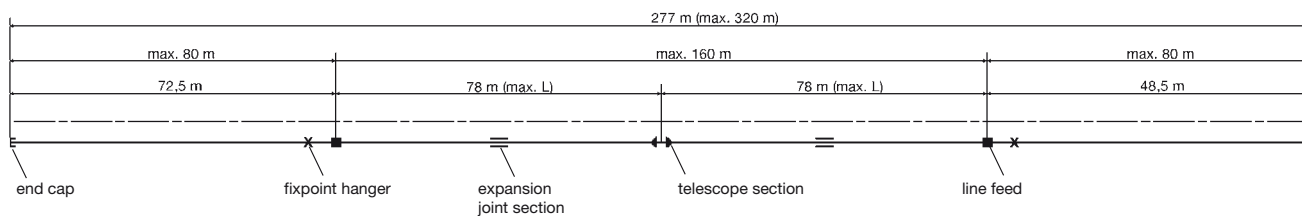

All other support points are sliding hangers, sealing strip „D“ and plastic shielding „FP“ have to be ordered separately with the corresponding collectors (see pages 6 and 20). Heating system may be provided. (see page 16).



Aluminium enclosed conductor system on crane bridge.



# BASIC DIMENSIONS

LSV

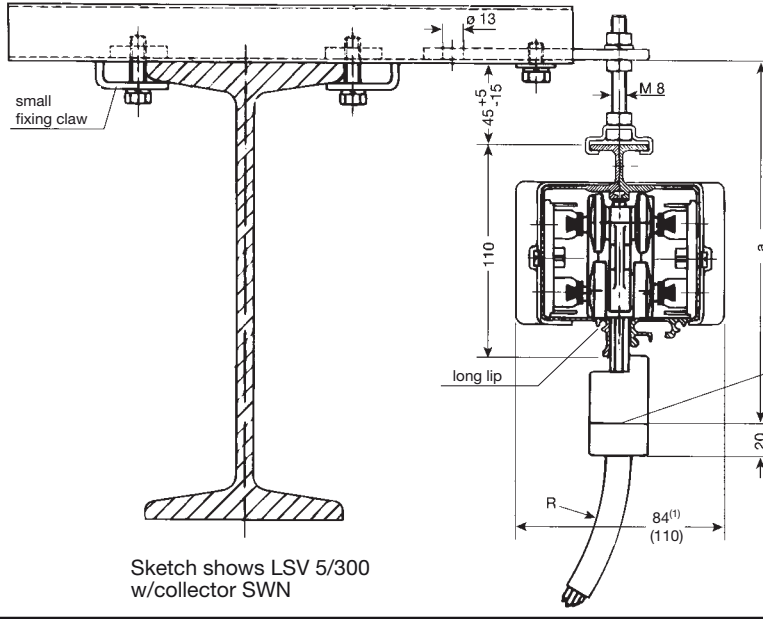

Sketch shows LSV 5/300 w/collector SWN

with collector	SWK	SWN	SWNT
Dim a mm	187 <sup>+5</sup> / <sub>-15</sub>	187 <sup>+5</sup> / <sub>-15</sub>	197 <sup>+5</sup> / <sub>-15</sub>

Dimensions also refer to corresponding double collectors.

LSVG

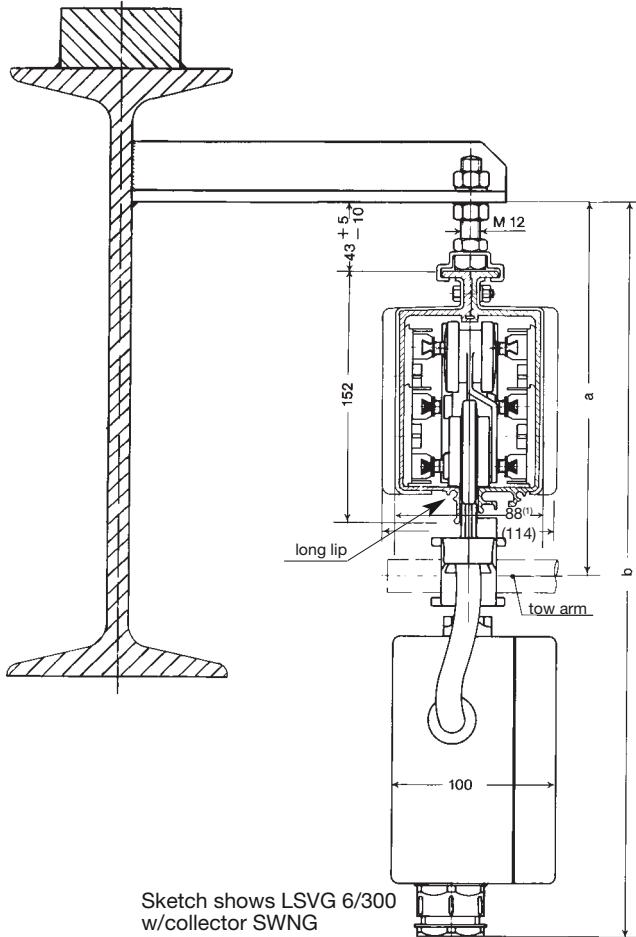

Sketch shows LSVG 6/300 w/collector SWNG

with collector	SWNG	DSWNG	SWNGT	DSWNGT
Dim a mm	225 <sup>+5</sup> / <sub>-10</sub>	255 <sup>+5</sup> / <sub>-10</sub>	243 <sup>+5</sup> / <sub>-10</sub>	268 <sup>+5</sup> / <sub>-10</sub>
Dim b mm	455 <sup>+5</sup> / <sub>-10</sub>	495 <sup>+5</sup> / <sub>-10</sub>	460 <sup>+5</sup> / <sub>-10</sub>	500 <sup>+5</sup> / <sub>-10</sub>

LSV  
LSVG

## Cable glands for Feeds (see pages 10 and 11)

cable gland	for cable-Ø mm	ampacity A
M 25	9 - 19	60
M 32	17 - 27	60
M 50	23 - 33	100 + 140
M 50	29 - 39	200
M 63	35 - 64	300

<sup>(1)</sup> For max. width see also pages 10 & 11 feed set configurations.

Max. width 84 or 88 mm at plug-in joints w/o bonded blanks.

Dimensions in parenthesis at bolted joints are with bonded blanks (see illustration).



Company: \_\_\_\_\_

Date: \_\_\_\_\_

Tel: \_\_\_\_\_

Fax: \_\_\_\_\_

E-Mail: \_\_\_\_\_

Internet: (URL) \_\_\_\_\_

1. Number of powerail installations: \_\_\_\_\_

2. Type of equipment to be powered: \_\_\_\_\_

3. Operating voltage: \_\_\_\_\_ Volts,                      Phases: \_\_\_\_\_,                      Frequency: \_\_\_\_\_ Hz  
Three phase voltage:                       AC voltage:                       DC voltage:

4. Track length: \_\_\_\_\_

5. Number of powerails: \_\_\_\_\_ (neutral: \_\_\_\_\_ control rails: \_\_\_\_\_ ground rail: \_\_\_\_\_)

6. Mounted position of powerail:

- Powerail pendant, collector cable facing to the bottom
- Support distance \_\_\_\_\_ m (max. 2 m)
- Other: \_\_\_\_\_

7. Number of consumers per system: \_\_\_\_\_

8. Indoor:                       Outdoor:

9. Other operating conditions (humidity, dust, chemical influence etc.)  
\_\_\_\_\_

10. Ambient temperature: \_\_\_\_\_ °C min. \_\_\_\_\_ °C max.

11. Position and number of feeding points and isolating sections<sup>(1)</sup>: \_\_\_\_\_

12. Position and number of isolating sections (e.g. for maintenance): \_\_\_\_\_

13. Brackets required: yes                       no                       c/c distance beam /Powerail

14. How are the rails laid out? (Please provide sketch): \_\_\_\_\_

15. Travel speed: \_\_\_\_\_

16. Power consumption of the individual consumer loads: \_\_\_\_\_  
(Please consult table on reverse side)

17. Max. Voltage drop from the powerail feed point to the consumer considering starting current:  
3%  or \_\_\_\_\_ %  referring to nominal voltage

Remarks: \_\_\_\_\_

<sup>(1)</sup> For curved tracks, powerail with isolating sections etc., we require sketches to enable us to prepare a quotation.



# QUESTIONNAIRE LSV-LSVG

To the nearest local VAHLE agency:

Date:

Motor data	Crane 1							Crane 2						
	Power kW	Nominal current			Starting current		Type of Motos <sup>(1)</sup>	Power kW	Nominal current			Starting current		Type of Motos <sup>(1)</sup>
		A	cos j <sub>N</sub>	% ED	A	cos j <sub>A</sub>			A	cos j <sub>N</sub>	% ED	A	cos j <sub>A</sub>	
Hoist motors														
Auxiliary hoist														
Long travel														
Cross travel														

Motor data	Crane 3							Crane 4						
	Power kW	Nominal current			Starting current		Type of Motos <sup>(1)</sup>	Power kW	Nominal current			Starting current		Type of Motos <sup>(1)</sup>
		A	cos j <sub>N</sub>	% ED	A	cos j <sub>A</sub>			A	cos j <sub>N</sub>	% ED	A	cos j <sub>A</sub>	
Hoist motors														
Auxiliary hoist														
Long travel														
Cross travel														

Mark with \* those motors which can run simultaneously.  
 Mark with Δ those motors which can start up simultaneously.

<sup>(1)</sup>Use:                    K for squirrel cage motor  
                               S for slipring motor  
                               F for frequency controlled motor

Further remarks: \_\_\_\_\_  
 \_\_\_\_\_  
 \_\_\_\_\_  
 \_\_\_\_\_

Signature: \_\_\_\_\_



<b>Products and Service</b>	<b>Catalog No.</b>
<b>1 Open conductor systems</b>	
Open conductor systems	1a
<b>2 Insulated conductor systems</b>	
U 10	2a
FABA 100	2b
U 15 - U 25 - U 35	2c
U 20 - U 30 - U 40	2d
<b>3 Compact conductor systems</b>	
VKS 10	3a
VKS - VKL	3b
<b>4 Enclosed conductor systems</b>	
KBSL - KSL	4a
KBH	4b
MKLD - MKLF - MKLS	4c
LSV - LSVG	4d
<b>5 Contactless power system</b>	
Contactless power system (CPS®)	5a
<b>6 Data transmission</b>	
VAHLE Powercom®	6a
Slotted Microwave Guide (SMG)	6b
<b>7 Positioning systems</b>	
VAHLE APOS®	7a
<b>8 Festoon systems and cables</b>	
Festoon systems for □- tracks	8a
Festoon systems for flat cables on I- tracks	8b
Festoon systems for round flat cables on I- tracks	8c
Festoon systems for ◇- tracks	8d
Cables	8e
<b>9 Reels</b>	
Spring operated cable reels	9a
Motor powered cable reels	9b
<b>10 Others</b>	
Battery charging systems	10a
Heavy enclosed conductor systems	10b
Tender	10c
Contact wire	10d

**Assemblies/Commissioning**

**Spare parts/Maintenance service**

