

POWERRAIL ENCLOSED CONDUCTOR SYSTEM

VKS 10



POWERRAIL ENCLOSED CONDUCTORS VKS 10

CONTENTS	Page
General	2, 3
Planning guide	4
Technical data, standard sections	6, 7
Curved sections	8
Jointing material	8
Hangers	9
End caps	9
Feeds	9, 10
Transfer funnels	11, 12
Powerail section isolation	12
Compact current collectors	13, 14
Accessories and spare parts for current collectors	15, 16
Support profile for high bay storage	17
Support profile attachments	18
Position encoding system WCS 3	19
Installation tools for VKS 10	20
Questionnaire ⁽¹⁾	21, 22
Manufacturing program	24

General

VAHLE Powerail Enclosed Conductors type VKS 10 are compact and shock hazard protected safety powerails. They consist of a flat-formed insulated housing with integrated copper conductors. These conductors are protected according to European standard EN 60529.

They comply with accident and VDE regulations in the context of electrical, mechanical and fire safety and are protected to IP21 standards. Collectors are proof against touch only when fully entered into the powerail.

Powerail installations within reach of hand require a special protection on the part of the operator against accidental touch of current collectors which are leaving the powerail (e.g. locking or cut-off the power).

This is only applicable for voltages above 25 V AC respectively 60 V DC.

The insulated housing accommodates up to 10 conductors. No special finishing work to the rail ends is necessary. The compact design allows direct mounting in runway beams and Vahle support profiles.

The powerail is only suitable for indoor installations and lateral positioning.

UL approved (Underwriter's Laboratories).

Powerail electrical values:

VKS 10

max. continuous current	= 140 A ⁽²⁾
Permitted operating voltage (UL)	= 690 V (600 V)
Dielectric strength in accord. with DIN 53481	> 25 kV/mm
Specific resistance in acc. with IEC 60093	> 1 x 10 ¹⁶ Ohm x cm
Surface resistivity IEC 60093	2,1 x 10 ¹⁵ Ohm
Leakage resistance in acc. with IEC 60112	= CTI >400
Combustibility in acc. with DIN 4102, part 1:	Class B1, flame retardant, self-extinguishing.

Chemical resistance of the insulated housing

Petrol, mineral oil, greases	resistant
Caustic soda up to 50%	resistant
Hydrochloric acid, concentrated	resistant
Sulfuric acid up to 50 %	resistant
UV (Xenon test >1500)	resistant

Water absorption: max. at 20 °C = 0.06%

Ambient temperature:

from -30 °C to + 55 °C (Application area)
 Max. temperature differences: 50 °C (50 ≤ Δ T) ⁽³⁾
 from -10 °C to + 40 °C with supply length = 6 m
 from -30 °C bis + 20 °C with supply length = 4 m (deep freeze storage⁽³⁾)

Conductor material	Copper				Units
	16	25	30	35	
Cross section					mm ²
Impedance at 50 Hz ⁽⁴⁾	1,106	0,728	0,602	0,518	Ohm/1000 m
Resistance	1,102	0,723	0,595	0,510	Ohm/1000 m
Ampacity	60	100	120	140 ⁽²⁾	Amp

Please note: When using extra-low voltages please submit detailed information with your inquiry, especially with regard to the ambient conditions.

In order to process quotations and orders, we require drawings if the powerail system includes with curves or rail section isolation

Please use our questionnaire on pages 18 and 19

⁽¹⁾ Please submit with your inquiry!

⁽²⁾ 80% duty cycle

⁽³⁾ Cold store applications on request

⁽⁴⁾ By parallel circuit (doubling of cross section) is the impedance and the resistance halved.

VKS-10 Powerail

Area of application: Indoor installation

Sections:

The insulated housing accommodates up to max. 10 conductors and provides reliable insulation. The standard length is 6 m, shorter lengths can be supplied. The ground conductor rail is identified with continuous yellow marking. The asymmetric design eliminates the possibility of reversing the phases during installation.

Joints:

The insulated housing sections are connected with joint caps, the conductors are joined with copper plug-in connectors.

Feeds:

Feed units can be supplied as end or line feeds with plastic terminal boxes or as especially flat line feeds for direct single core cable connection. Both line feed types are supplied preassembled on a 1 m powerail section.

The end feeds are supplied loose and can only be used in conjunction with the VLS line feed.

Hangers:

The maximum distance between suspension points must not exceed 1.2 m. The hangers are available for the following mounting options:

- for assembly in VAHLE support profile (self-locking)
- for assembly in c-rail (bolted type)
- for assembly to plain surface (bolted type)

The powerail can move with the sliding hangers for longitudinal expansion. One fixpoint hanger is required for each powerail section.

Isolating sections:

Conductor dead sections are electrical interrupts of the conductor. Under normal operating conditions a cross over with collectors to switch the voltage off or on is only allowed with low power ratings (control current).

Conductor dead sections can be mounted at any position of the system. The plastic inserts are pushed into the copper profiles and ensure a smooth transfer of the collector brushes.

The length of the isolating section has to consider the total length of the carbon brush and whether the carbon brush must or must not bridge the isolation area.

Special attention is required for double collectors or collectors switched in parallel. Use double isolating sections where necessary.

Current collectors:

The current collectors are manufactured from impact resistant plastic and stainless steel parts. The current is transmitted by a carbon brush. According to the application, one or more current collectors are required per phase and per ground conductor. The current collectors for the ground conductor can be identified by yellow color-coding and are equipped with different fixings to make them non-interchangeable with the phase current collectors. Springs in the current collectors ensure even pressure of the carbon brush against the conductor, thus maintaining reliable contact.

The current collectors must be mounted on base plates or rectangular brackets.

The connection cables provided (H07 RN-F) are adequately sized for the specified nominal current. Reduction factors in accordance with DIN VDE 0298-4 are to be taken into account for various layout methods.

Electronic layout support:

Please use our electronic layout software





PLANNING GUIDE VKS 10

1. System diagram

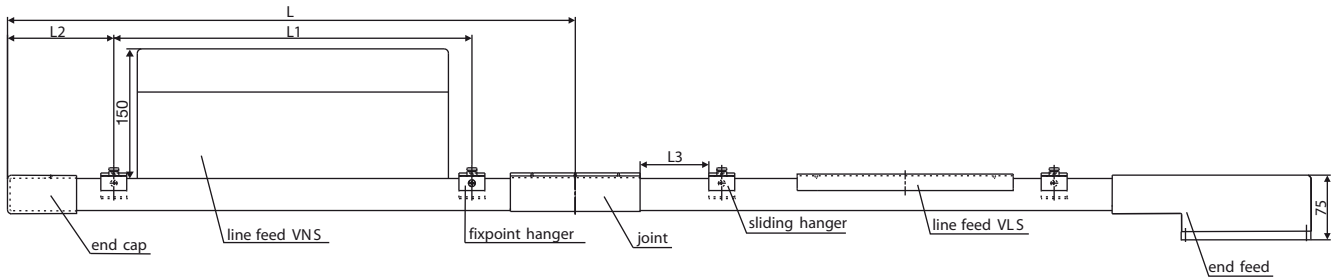

- L = length of powerail section
- L₁ = distance for straight runs: max. 1.2 m
in curves: max. 0.6 m
- L₂ = overhang (max. 300 mm)
- L₃ = distance, to be allowed for powerail expansion (min. 50 mm)

2. Symbols used in installation drawing

Symbol	Description	Code
-----	Runway	-
=====	Powerail	VKS 10
— —	Joint	SV
—*—	Fixpoint hanger	VEPS
—•—	Sliding hanger	VAS
[]	End cap	VES
■	End feed	VEKS
—■—	Line feed	VLS, VNS
— —	Section isolator	VSTS
▷	Transfer funnel	EFT- V10

3. Max. hanger distance

- a) Powerail VKS 10
 - in straight runs 1.2 m
 - in curves 0.6 m
 - Horizontal 0,6 m
- b) Support profile VTP 10
 - on rack uprights 4.5 m
 - on support posts 4.0 m
 - Horizontal arrangement 3,0 m
 - Attached to the wall 3,0 m

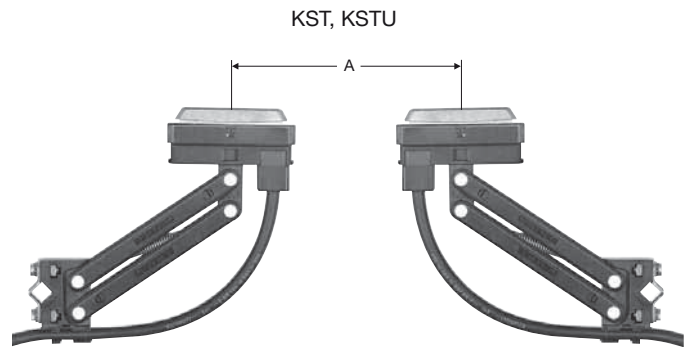

A ≥ 250 mm KST, KSTU, KESL
A ≥ 180 mm KESR

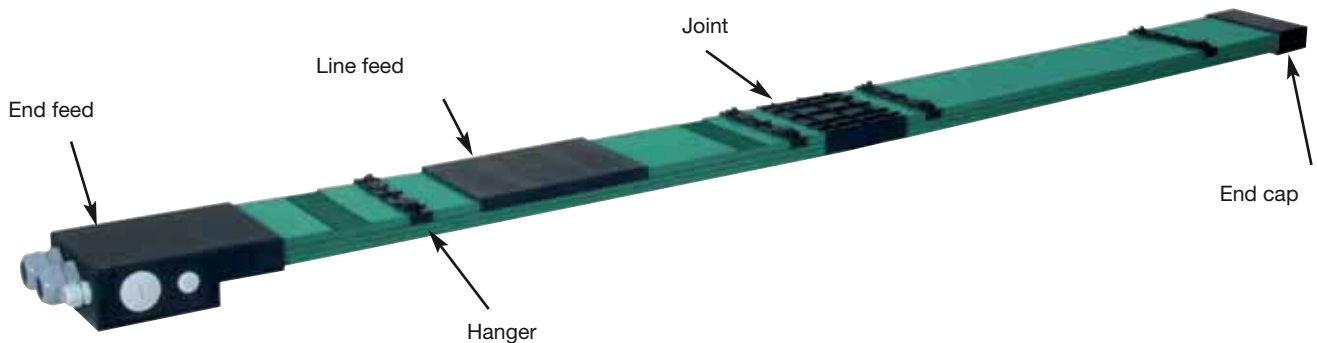

Lateral mounting only



VKS 10 in high bay warehouses





TECHNICAL DATA VKS 10

Sections

Standard lengths: 6 m
Cold stores: 4 m

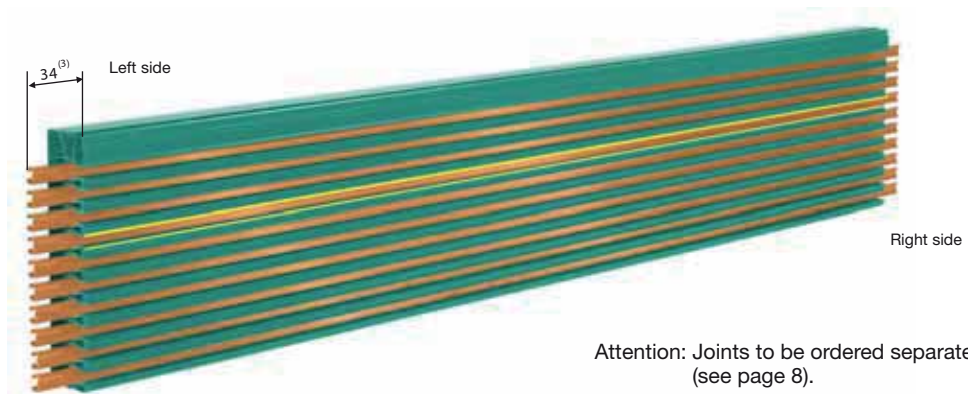

HS= with ground (PE)

Attention: Joints to be ordered separately
(see page 8).

Type	No. of Conductors	Max. continuous current A at 35 °C	Max. voltage V	Conductor cross section mm ²			Conductor material	Weight kg/m	Order-No.
				L1-L3	Ground	5-10 ⁽⁴⁾			
VKS 10-6/ 60-6 HS	6	60	690	3 x 16	1 x 16	2 x 16	Cu	2.30	780 04•
VKS 10-6/100-6 HS	6	100	690	3 x 25	1 x 16	2 x 16	Cu	2.54	780 05•
VKS 10-6/120-6 HS	6	120	690	3 x 30	1 x 16	2 x 16	Cu	2.64	780 06•
VKS 10-6/140-6 HS	6	140 ⁽¹⁾	690	3 x 35	1 x 16	2 x 16	Cu	2.81	780 07•
VKS 10-7/ 60-6 HS	7	60	690	3 x 16	1 x 16	3 x 16	Cu	2.45	780 03•
VKS 10-7/100-6 HS	7	100	690	3 x 25	1 x 16	3 x 16	Cu	2.68	780 08•
VKS 10-7/120-6 HS	7	120	690	3 x 30	1 x 16	3 x 16	Cu	2.81	780 09•
VKS 10-7/140-6 HS	7	140 ⁽¹⁾	690	3 x 35	1 x 16	3 x 16	Cu	2.95	780 01•
VKS 10-8/ 60-6 HS	8	60	690	3 x 16	1 x 16	4 x 16	Cu	2.59	780 21•
VKS 10-8/100-6 HS	8	100	690	3 x 25	1 x 16	4 x 16	Cu	2.83	780 22•
VKS 10-8/120-6 HS	8	120	690	3 x 30	1 x 16	4 x 16	Cu	2.96	780 23•
VKS 10-8/140-6 HS	8	140 ⁽¹⁾	690	3 x 35	1 x 16	4 x 16	Cu	3.09	780 24•
VKS 10-9/ 60-6 HS	9	60	690	3 x 16	1 x 16	5 x 16	Cu	2.74	780 25•
VKS 10-9/100-6 HS	9	100	690	3 x 25	1 x 16	5 x 16	Cu	2.97	780 26•
VKS 10-9/120-6 HS	9	120	690	3 x 30	1 x 16	5 x 16	Cu	3.11	780 27•
VKS 10-9/140-6 HS	9	140 ⁽¹⁾	690	3 x 35	1 x 16	5 x 16	Cu	3.24	780 28•
VKS 10-9/200-6 HS	9	200 ⁽²⁾	690	6 x 25	1 x 25	2 x 16	Cu	3.28	780 14•
VKS 10-9/240-6 HS	9	240 ⁽²⁾	690	6 x 30	1 x 30	2 x 16	Cu	3.60	780 13•
VKS 10-9/280-6 HS	9	280 ^{(1) (2)}	690	6 x 35	1 x 35	2 x 16	Cu	3.91	780 12•
VKS 10-10/ 60-6 HS	10	60	690	3 x 16	1 x 16	6 x 16	Cu	2.88	780 29•
VKS 10-10/100-6 HS	10	100	690	3 x 25	1 x 16	6 x 16	Cu	3.11	780 20•
VKS 10-10/120-6 HS	10	120	690	3 x 30	1 x 16	6 x 16	Cu	3.25	780 30•
VKS 10-10/140-6 HS	10	140 ⁽¹⁾	690	3 x 35	1 x 16	6 x 16	Cu	3.38	780 31•
VKS 10-10/200-6 HS	10	200 ⁽²⁾	690	6 x 25	1 x 25	3 x 16	Cu	3.43	780 10•
VKS 10-10/240-6 HS	10	240 ⁽²⁾	690	6 x 30	1 x 30	3 x 16	Cu	3.74	780 11•
VKS 10-10/280-6 HS	10	280 ^{(1) (2)}	690	6 x 35	1 x 35	3 x 16	Cu	4.05	780 02•

⁽¹⁾ At 80% duty cycle

⁽²⁾ 2 conductors per phase.

⁽³⁾ Powerail projecting length 34 mm at 20 °C ambient.

⁽⁴⁾ Consult factory in case of circuits incl. N conductors.

• Supplement type designations, e.g. 2 m VKS 10-6/60 with PE (ground)
→VKS 10-6/60 - **2 HS** Order-No. 780042.

Short lengths will be produced out of the next larger rail section.

STANDARD SECTIONS VKS 10

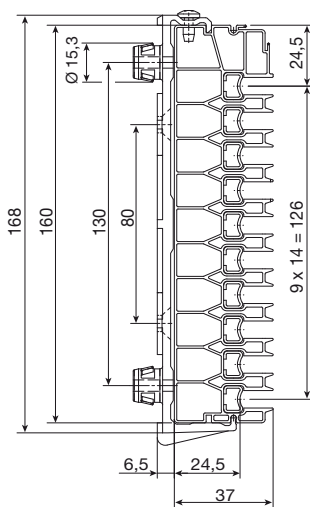
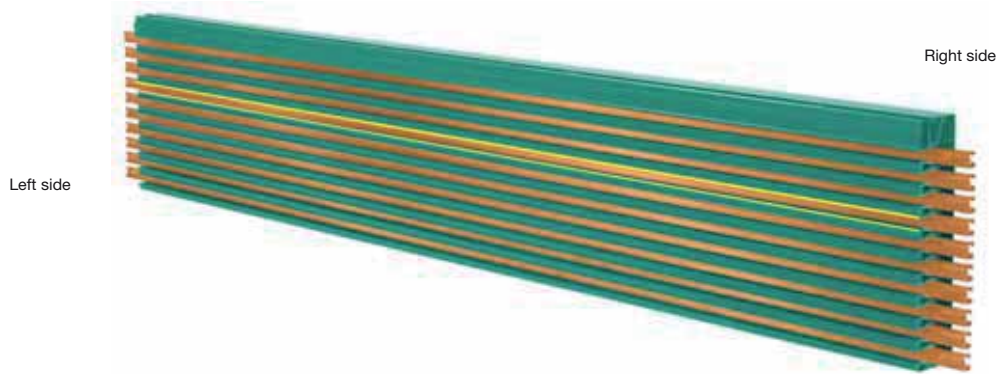

VKS 10-6/ 60-140	VKS 10-7/ 60-140	VKS 10-8/ 60-140
L1	L1	L1
L2	L2	L2
L3	L3	L3
PE (ground)	PE (ground)	PE (ground)
5	5	5
6	6	6
Free	7	7
Free	Free	8
Free	Free	Free
Free	Free	Free

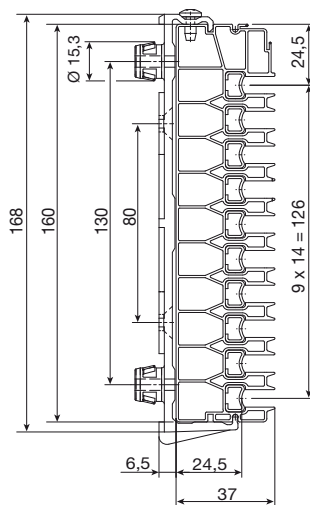

VKS 10-9/ 60-140	VKS 10-9/ 200-280	VKS 10-10/ 60-140	VKS 10-10/200-280
L1	L1	L1	L1
L2	L2	L2	L2
L3	L3	L3	L3
PE (ground)	PE	PE (ground)	PE (ground)
5	L1	5	L1
6	L2	6	L2
7	L3	7	L3
8	8	8	8
9	9	9	9
Free	Free	10	10



CURVED SECTIONS AND JOINTS VKS 10

Curved sections

vertical in accordance with your design drawings
Copper cross section min. 25 mm²

- Max. length of bend = 5.3 m
- Hanger distance ≈ 0.6 m
- Max. angle = 180°
- Inside bend = conductors inside
- Outside bend = conductors outside (not shown)

Inside bend R Outside bend R

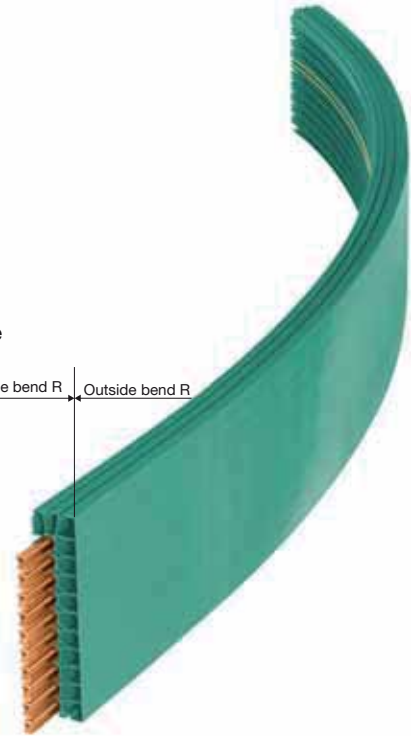

Bends are supplied with straight ends, each 200 mm long.

Type	R mm ⁽²⁾	Order-No.
Inside bend (as shown)	≥ 1000	780 344
Outside bend	≥ 1500	780 345

Joints

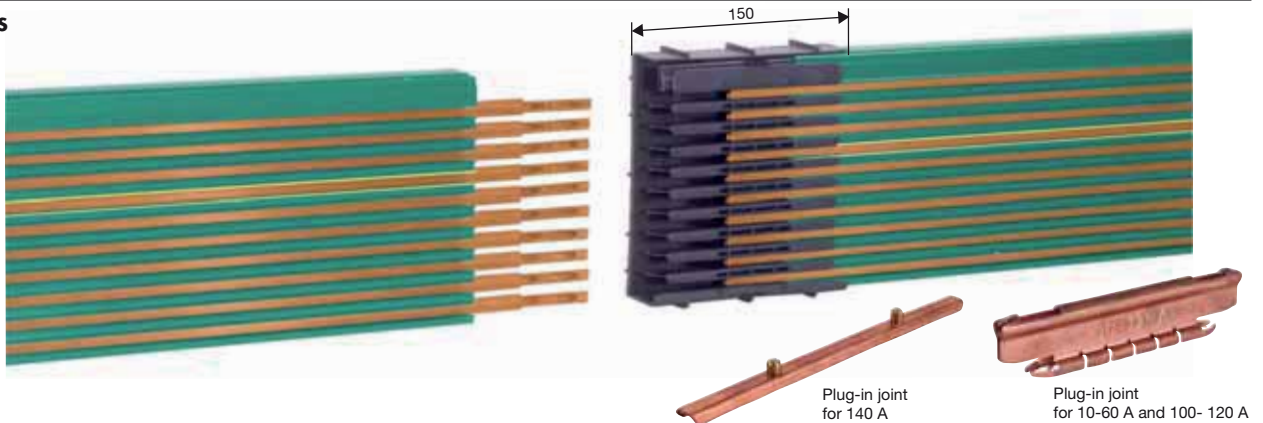

Type	No. of conductors	Weight kg	Order-No.
SV 10- 6/ 60	6	0,407	781 150
SV 10- 6/100-120	6	0,407	781 151
SV 10- 6/140	6	0,388	781 152
SV 10- 7/ 60	7	0,429	781 153
SV 10- 7/100-120	7	0,429	781 154
SV 10- 7/140	7	0,410	781 155
SV 10- 8/ 60	8	0,451	781 156
SV 10- 8/100-120	8	0,451	781 157
SV 10- 8/140	8	0,432	781 158
SV 10- 9/ 60	9	0,473	781 159
SV 10- 9/100-120	9	0,473	781 160
SV 10- 9/140	9	0,454	781 161
SV 10- 9/200-240 ⁽¹⁾	9	0,473	781 162
SV 10- 9/280 ⁽¹⁾	9	0,423	781 163
SV 10-10/ 60	10	0,495	781 164
SV 10-10/100-120	10	0,495	781 165
SV 10-10/140	10	0,476	781 166
SV 10-10/200-240 ⁽¹⁾	10	0,495	781 167
SV 10- 10/280 ⁽¹⁾	10	0,450	781 168

⁽¹⁾ Conductor rails connected in parallel
⁽²⁾ Smaller radius on request

FIXPOINT HANGERS, SLIDING HANGERS, END CAPS, END FEEDS VKS 10



Fixpoint hanger on C-rail
consisting of hanger clamp and fixing screw and C-rail

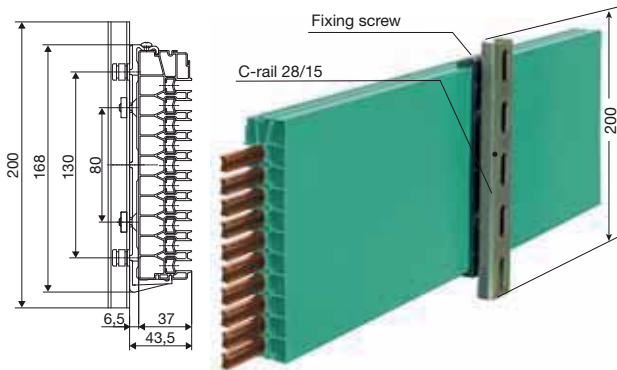

Type	Weight kg	Order-No.
VEPS 10-H	0.224	780 007

Sliding hanger on C-rail
consisting of hanger clamp and C-rail

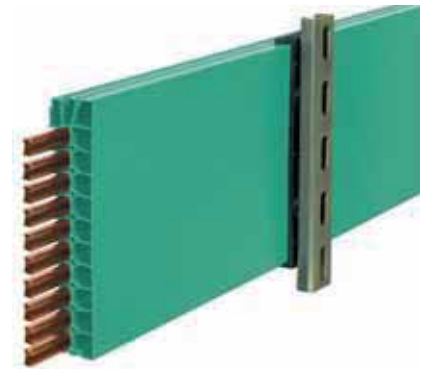

Type	Weight kg	Order-No.
VAS 10-H	0.223	780 008

Fixpoint hanger for support profile VTP 10
consisting of hanger and fixing screw

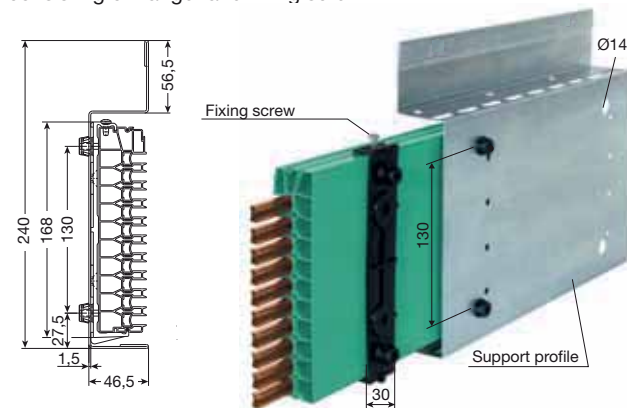

Type	Weight kg	Order-No.
VEPS 10-VTP	0.033	780 009

Sliding hanger for support profile VTP 10
consisting of hanger clamp

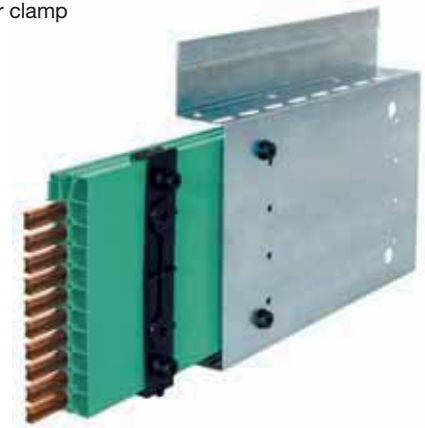

Type	Weight kg	Order-No.
VAS 10-VTP	0.032	780 010

End cap

Can be used right or left handed.
Supplied loose as individual part with fixing screws.

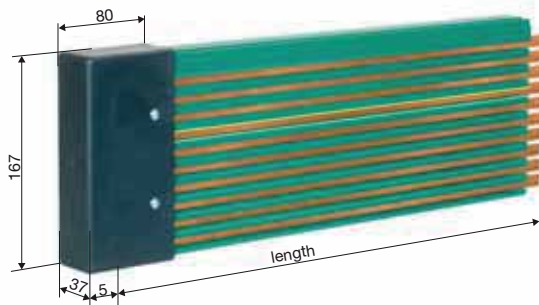

Type	Weight kg	Order-No.
VES 10 L	0.210	780 004

End feed⁽¹⁾

Terminal box supplied loose,
only in conjunction with line feed VLS⁽²⁾

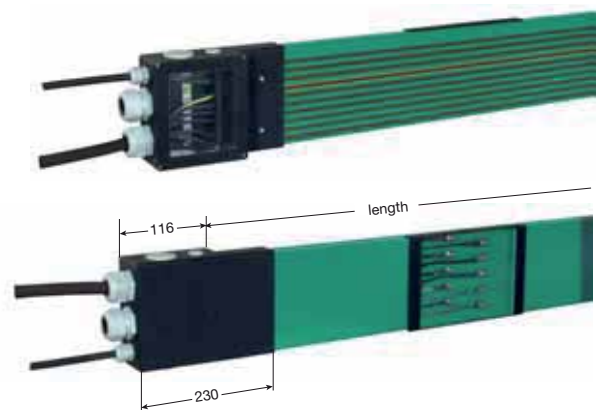

Type	Weight kg	Order-No.
VEKS 10-10/ 60-280	0.664	780 018

⁽¹⁾ Cable glands, 2 x ST-M 40 x 1.5 for D = 19-28 mm
1 x ST-M 20 x 1.5 for D = 7-13 mm

⁽²⁾ Please order VLS line feed separately.



LINE FEED VKS 10

Line feed VLS

for direct connection of single core cables

M6 terminal with special cable shoe for single core cables;
 35 mm² (up to cable Ø 8.5 mm) for 140 A,
 25 mm² (up to cable Ø 8.2 mm) for 100 A - 120 A,
 or feed bolts for 60 A powerail

1 m section to be ordered separately.

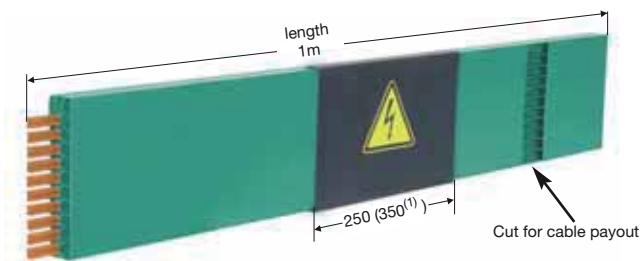

Type	No. of conductors	Current capacity A	Weight kg	Order-No.
VLS 10- 6/ 60	6	60	0,217	780 047
VLS 10- 6/100-120	6	100-120	0,382	780 060
VLS 10- 6/140	6	140	0,574	780 187
VLS 10- 7/ 60	7	60	0,230	780 049
VLS 10- 7/100-120	7	100-120	0,426	780 188
VLS 10- 7/140	7	140	0,630	780 189
VLS 10- 8/ 60	8	60	0,243	780 050
VLS 10- 8/100-120	8	100-120	0,470	780 196
VLS 10- 8/140	8	140	0,686	780 198
VLS 10- 9/ 60	9	60	0,256	780 058
VLS 10- 9/100-120	9	100-120	0,514	780 199
VLS 10- 9/140	9	140	0,742	780 191
VLS 10- 9/200-240 ⁽¹⁾	9	200-240	0,744	780 322
VLS 10- 9/280 ⁽¹⁾	9	280	0,828	780 321
VLS 10-10/ 60	10	60	0,269	780 059
VLS 10-10/100-120	10	100-120	0,558	780 192
VLS 10-10/140	10	140	0,798	780 208
VLS 10-10/200-240 ⁽¹⁾	10	200-240	0,757	780 318
VLS 10-10/280 ⁽¹⁾	10	280	0,815	780 317

Cable payout left, standard.
 Cable payout right, possible.
 Please specify on your order.

Line feed VNS

with terminal box

Cable gland: STR - M63 x 1,5 for Ø = 34-45
 STR - M20 x 1,5 for Ø = 7-13

Connection cable to be supplied by customer

Cable connection: Main current: M10
 Control current: M6

1 m section to be ordered separately.

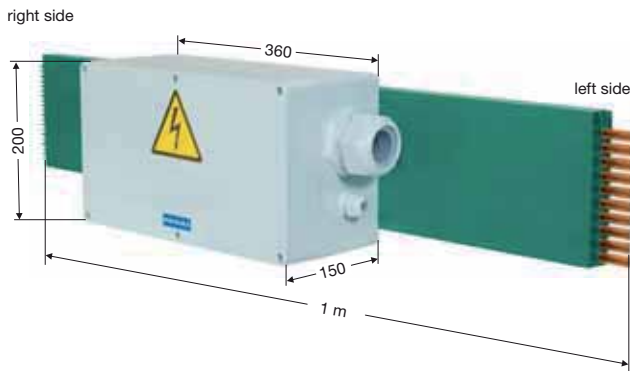

Type	No. of poles	Current capacity A	Weight kg	Order-No.
VNS 10- 6/ 60-140	6	60-140	2,766	780 327
VNS 10- 7/ 60-140	7	60-140	2,952	780 328
VNS 10- 8/ 60-140	8	60-140	3,138	780 329
VNS 10- 9/ 60-140	9	60-140	3,324	780 330
VNS 10- 9/200-280	9	200-280	2,840	780 334
VNS 10-10/ 60-140	10	60-140	3,510	780 331
VNS 10-10/200-280	10	200-280	2,865	780 332

Cable payout left, standard

TRANSFER FUNNELS VKS 10



Transfer funnel ⁽¹⁾ for current collector KSTU 30-55/14
max. speed v= 100 m/min.

Conductor rails for funnels (all cross sections 25 mm², length 1365 mm)



Tolerances:
x = ± 15 mm
y = ± 15 mm

Type	Order-No.
No. of conductors 6	780 247
No. of conductors 7	780 248
No. of conductors 8	780 249
No. of conductors 9	780 250
No. of conductors 10	780 257

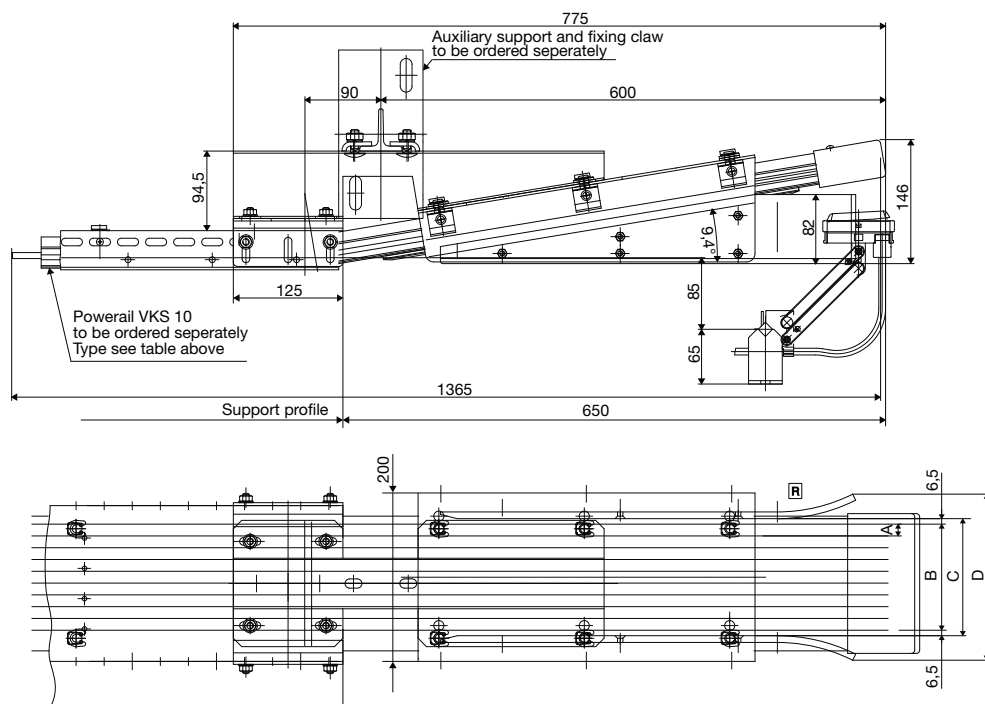

Type	No. of conductors	A mm	B mm	C mm	D mm	E mm	Weight kg	Order-No.
EFTV 10- 6-KSTU 30/55 - 14 L	6	14	70	83	137	64	7.574	780 350
EFTV 10- 6-KSTU 30/55 - 14 R	6	14	70	83	137	64	7.574	780 173
EFTV 10- 7-KSTU 30/55 - 14 L	7	14	84	97	151	50	7.564	780 349
EFTV 10- 7-KSTU 30/55 - 14 R	7	14	84	97	151	50	7.564	780 172
EFTV 10- 8-KSTU 30/55 - 14 L	8	14	98	111	165	36	7.554	780 348
EFTV 10- 8-KSTU 30/55 - 14 R	8	14	98	111	165	36	7.554	780 171
EFTV 10- 9-KSTU 30/55 - 14 L	9	14	112	125	179	22	7.544	780 347
EFTV 10- 9-KSTU 30/55 - 14 R	9	14	112	125	179	22	7.544	780 170
EFTV 10-10-KSTU 30/55 - 14 L	10	14	126	139	193	6	7.534	780 346
EFTV 10-10-KSTU 30/55 - 14 R	10	14	126	139	193	6	7.534	780 169

⁽¹⁾ Transfer funnel only in combination with powerail section. Higher speeds on request.



TANGENTIAL ENTRY FUNNEL, POWERRAIL SECTION ISOLATION VKS 10

Tangential funnel for current collector KSTU 30 - 55/14

max. entry speed $v = 100$ m/min.
Copper cross section min. 25 mm^2

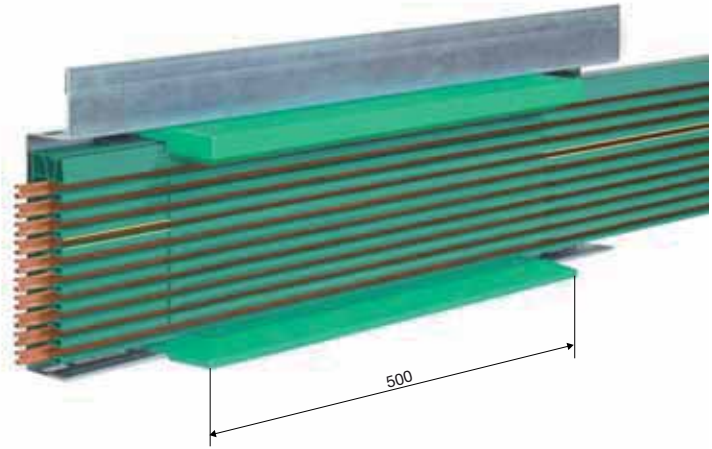
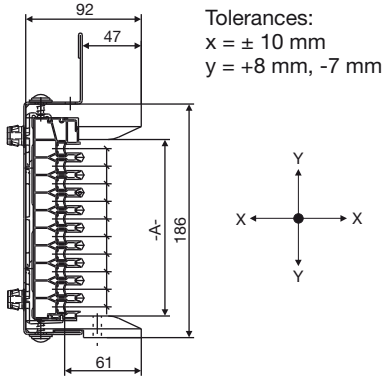

Transfer guide VU 10

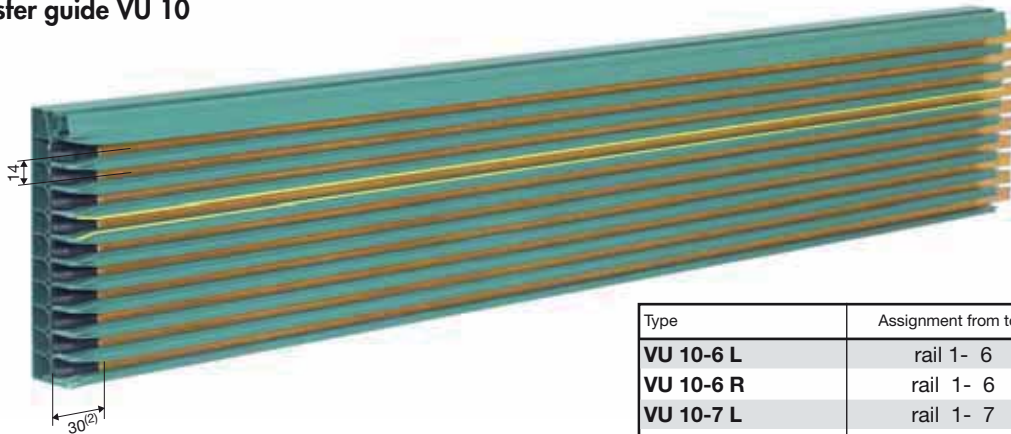

For cross travel and terminal lines
max. height- and lateral off-set: $\pm 2 \text{ mm}$

max. air gap between the transfer guides: 5 mm

Type	Assignment from top	Order-No.
VU 10-6 L	rail 1- 6	780 287
VU 10-6 R	rail 1- 6	780 288
VU 10-7 L	rail 1- 7	780 227
VU 10-7 R	rail 1- 7	780 228
VU 10-8 L	rail 1- 8	780 229
VU 10-8 R	rail 1- 8	780 230
VU 10-9 L	rail 1- 9	780 289
VU 10-9 R	rail 1- 9	780 290
VU 10-10 L	rail 1-10	780 269
VU 10-10 R	rail 1-10	780 270

Powerail isolating section⁽¹⁾

The position of the isolating sections are to be identified in the order.

Type	Weight kg	Order-No.
VSTS 1/10-60 M	0,004	156 933
VSTS 1/10-60 L	0,004	156 934
VSTS 1/ 100 M	0,004	150 150
VSTS 1/ 100 L	0,004	150 419
VSTS 1/ 120 M	0,004	151 674
VSTS 1/ 120 L	0,004	151 669
VSTS 1/ 140 M	0,004	156 335
VSTS 1/ 140 L	0,004	156 336

M = factory assembled; L = supplied loose

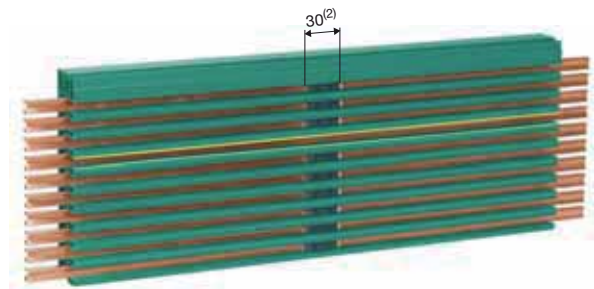

⁽¹⁾ For specification of the powerail profile see page 6

⁽²⁾ Length of the conductor dead section (longer dead sections on request).



Compact current collector KESR 32/55 two-way conveying

Distance between conductors: 14 mm

max. current	flat plug	bolted connection
32 A	FLA 2,5	AEA 2,5
40 A	FLA 4,0	AEA 4,0
55 A	FLA 6,0	AEA 6,0

Lift and swivel ± 15 mm
 Contact pressure: approx. 3.5 N per carbon brush
 PE (ground) on no. 4, other combinations possible

The ground collector always moves first when entering the powerail.

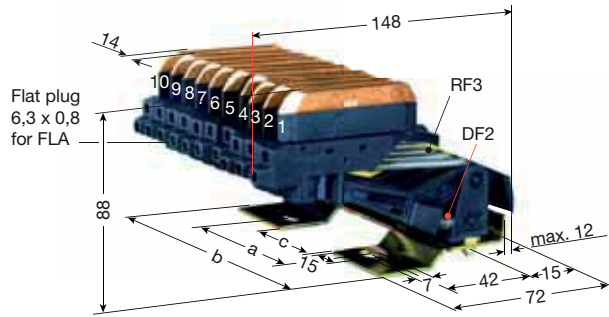

KESR-F

for connecting cables with flat plug
 see table 1 page 15

Type	No. of poles	a mm	b mm	c mm	Weight kg	Baseplate	Order-No.
KESR 32-55 F 6-14 HS	6	56	90	-	0,520	6 pole	143 113
KESR 32-55 F 7-14 HS	7	80	118	53	0,654	8 pole (no. 8= free)	143 114
KESR 32-55 F 8-14 HS	8	80	118	53	0,721	8 pole	143 115
KESR 32-55 F 9-14 HS	9	80	146	53	0,760	10 pole (no. 10= free)	143 116
KESR 32-55 F 10-14 HS	10	80	146	53	0,828	10 pole	143 117
Single collector: Current collector KESR 32-55 F 14						0,060	Phase PE (ground) 143 111

KESR-S

for connecting cables with bolted connection
 see table 2 page 15

Type	No. of poles	a mm	b mm	c mm	Weight kg	Baseplate	Order-No.
KESR 32-55 S 6-14 HS	6	56	90	-	0,636	6 pole	142 939
KESR 32-55 S 7-14 HS	7	80	118	53	0,702	8 pole (no. 8= free)	142 940
KESR 32-55 S 8-14 HS	8	80	118	53	0,768	8 pole	142 941
KESR 32-55 S 9-14 HS	9	80	146	53	0,834	10 pole (no. 10= free)	142 942
KESR 32-55 S 10-14 HS	10	80	146	53	0,890	10 pole	142 943
Single collector: Current collector KESR 32-63 S/14 ⁽¹⁾						0,066	Phase PE (ground) 143 120 143 121

Compact current collector KESR 63 S for reverse run with adapter plate and clamping block.

Spare parts

Type	Order-No.
Carbon MK 63 S/14.28	780 921
Current collector KESR 32-63 S/14 PE	143 121
Current collector KESR 32-63 S/14 PH	143 120

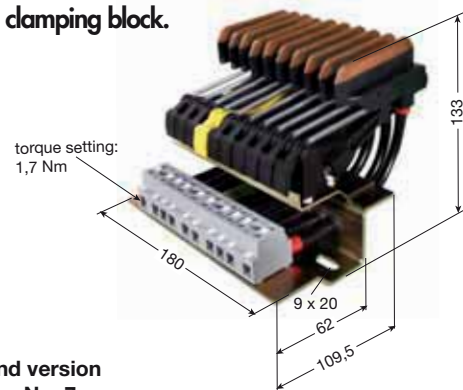

Left hand version Ground on No.4

Type	No. of poles	Configuration	Order-No.
KESR 63 S- 4-14 HS- KBL	4	1- 4	781 089
KESR 63 S- 5-14 HS- KBL	5	1- 5	781 088
KESR 63 S- 6-14 HS- KBL	6	1- 6	781 087
KESR 63 S- 7-14 HS- KBL	7	1- 7	781 086
KESR 63 S- 8-14 HS- KBL	8	1- 8	781 085
KESR 63 S- 9-14 HS- KBL	9	1- 9	781 084
KESR 63 S-10-14 HS- KBL	10	1-10	781 083

Right hand version Ground on No. 7

Type	No. of poles	Configuration	Order-No.
KESR 63 S- 4-14 HS- KBR	4	7-10	781 096
KESR 63 S- 5-14 HS- KBR	5	6-10	781 095
KESR 63 S- 6-14 HS- KBR	6	5-10	781 094
KESR 63 S- 7-14 HS- KBR	7	4-10	781 093
KESR 63 S- 8-14 HS- KBR	8	3-10	781 092
KESR 63 S- 9-14 HS- KBR	9	2-10	781 091
KESR 63 S-10-14 HS- KBR	10	1-10	781 090

⁽¹⁾ Only in combination with clamping block and 10 mm² connecting cable.



CURRENT COLLECTOR VKS 10

Compact current collector KESL 32-63 F two-way conveying

Distance between conductors: 14 mm

max. current	flat plug	bolted connection
32 A	FLA 2,5	AEA 2,5
40 A	FLA 4,0	AEA 4,0
55 A	FLA 6,0	AEA 6,0
63 A	-	AEA 10,0

Lift and swivel ± 15 mm

Contact pressure: approx. 3.5 N per carbon brush

PE (ground) on no. 4, other combinations possible

The ground collector always moves first when entering the powerail.

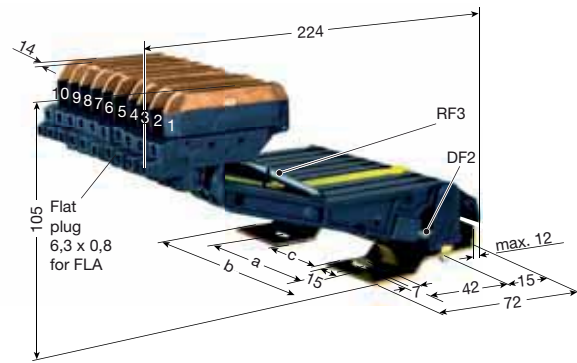

KESL-F

for connecting cables with flat plug

see table 1 page 15

Type	No. of poles	a mm	b mm	c mm	Weight kg	Baseplate	Order-No.
KESL 32-55 F 6-14 HS	6	56	90	-	0,688	6 pole	142 883
KESL 32-55 F 7-14 HS	7	80	118	53	0,764	8 pole (no. 8= free)	142 884
KESL 32-55 F 8-14 HS	8	80	118	53	0,840	8 pole	142 885
KESL 32-55 F 9-14 HS	9	80	146	53	0,916	10 pole (no. 10= free)	142 886
KESL 32-55 F 10-14 HS	10	80	146	53	0,992	10 pole	142 887
Single collector: Current collector KESL 32-55 F/14							Phase PE (ground) 142 881 142 882

KESL-S

for connecting cables with bolted connection

see table 2 page 15

Type	No. of poles	a mm	b mm	c mm	Weight kg	Baseplate	Order-No.
KESL 32-63 S 6-14 HS	6	56	90	-	0,721	6 pole	142 888
KESL 32-63 S 7-14 HS	7	80	118	53	0,803	8 pole (no. 8= free)	142 889
KESL 32-63 S 8-14 HS	8	80	118	53	0,885	8 pole	142 890
KESL 32-63 S 9-14 HS	9	80	146	53	0,967	10 pole (no. 10= free)	142 891
KESL 32-63 S 10-14 HS	10	80	146	53	1,049	10 pole	142 892
Single collector: Current collector KESL 32-63 S/14							Phase PE (ground) 168 395 142 880

Compact current collector KESL 63 S for reverse run with adapter plate and clamping block.

Spare parts

Type	Order-No.
Carbon MK 63 S/14.28	780 921
Current collector KESL 32-63S/14 PE	142 880
Current collector KESL 32-63S/14 PH	168 395

Left hand version

Ground on No.4

Type	No. of poles	Configuration	Order-No.
KESL 63S- 4-14 HS- KBL	4	1- 4	781 075
KESL 63S- 5-14 HS- KBL	5	1- 5	781 074
KESL 63S- 6-14 HS- KBL	6	1- 6	781 073
KESL 63S- 7-14 HS- KBL	7	1- 7	781 072
KESL 63S- 8-14 HS- KBL	8	1- 8	781 071
KESL 63S- 9-14 HS- KBL	9	1- 9	781 070
KESL 63S-10-14 HS- KBL	10	1-10	781 069

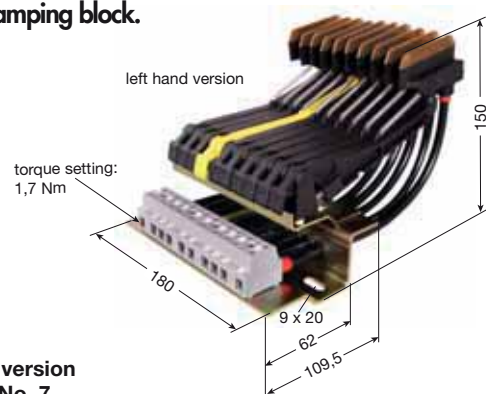

Right hand version

Ground on No. 7

Type	No. of poles	Configuration	Order-No.
KESL 63S- 4-14 HS- KBR	4	7-10	781 082
KESL 63S- 5-14 HS- KBR	5	6-10	781 081
KESL 63S- 6-14 HS- KBR	6	5-10	781 080
KESL 63S- 7-14 HS- KBR	7	4-10	781 079
KESL 63S- 8-14 HS- KBR	8	3-10	781 078
KESL 63S- 9-14 HS- KBR	9	2-10	781 077
KESL 63S-10-14 HS- KBR	10	1-10	781 076

CURRENT COLLECTOR VKS 10, ACCESSORIES



Current collector KST

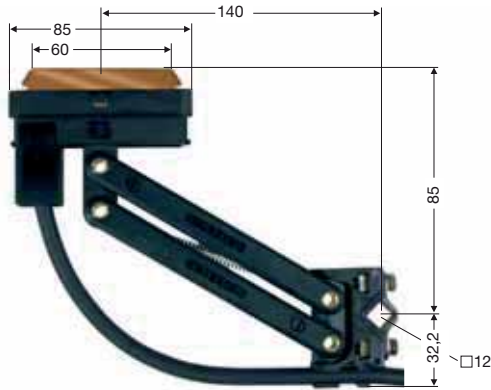

With 2 m connecting cables
Lift and swivel: see following table
Contact pressure: approx. 5 N

Current collector KSTU

for transfer funnel EFTV 10 and
for tangential funnel DSEV

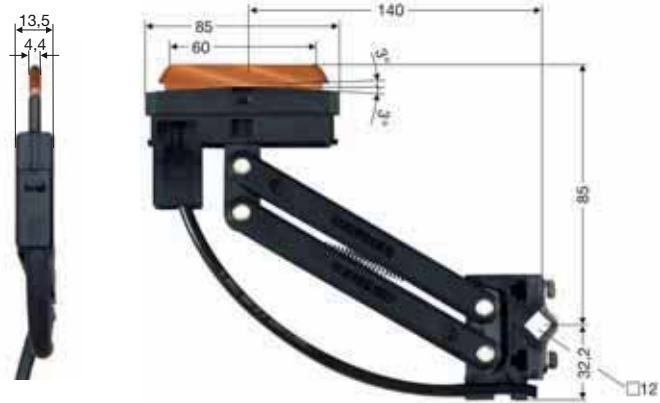

With 2 m connecting cables
Lift and swivel ± 20 mm
(in funnel area ± 15 mm in all directions)
Contact pressure: approx. 5 N

Type	Current capacity A	Connection cable		Lift+swivel mm	Weight kg	Order-No.		Type	Current capacity A	Connection cable		Lift+swivel mm	Weight kg	Order-No.	
		A/mm ²	d max./mm			Phase black	(ground) yellow			A/mm ²	d max./mm			Phase black	ground yellow
KST 30	30	2,50	5	± 20	0,240	152 085	152 086	KSTU 55/14	55	6,00	11	± 20	0,368	168 361	168 362
KST 55	55	6,00	11	± 20	0,368	154 438	154 439	KSTU 30/14	30	2,50	5	± 20	0,240	168 363	168 364

Connecting cable, highly flexible, for current collectors.
(For allocation to current collectors see page 13 and 14)



Length = 1 m with flat plug 6,3 x 0,8
Longer connecting length available.

Connecting cable AEA, highly flexible for current collectors



Length: 1 m
Longer connecting length available.

Table 1

Type	Cross section mm ²	Outside \varnothing mm	Weight kg	Order-No.	
				Phase black	PE green/yellow
FLA 2,5	2,50	4,00	0,080	165 049	165 050
FLA 4	4,00	6,00	0,100	165 051	165 052
FLA 6	6,00	7,00	0,150	166 368	166 369

Table 2

Type	Cross section mm ²	Outside \varnothing mm	Weight kg	Order-No.	
				Phase black	PE green/yellow
AEA 2,5	2,50	4,00	0,038	143 080	143 079
AEA 4,0	4,00	5,50	0,063	143 078	143 077
AEA 6,0	6,00	6,00	0,085	143 076	143 075
AEA 10,0	10,00	8,50	0,160	143 074	143 073

Flat plug, single

Type	for cable cross section mm ²	Order-No.
FH 2,5	2,50	165 120
FH 4-6	4,00 + 6,00	165 121





ACCESSORIES FOR CURRENT COLLECTORS VKS 10

Collector bracket

for current collectors
KST 30-55 see page 13

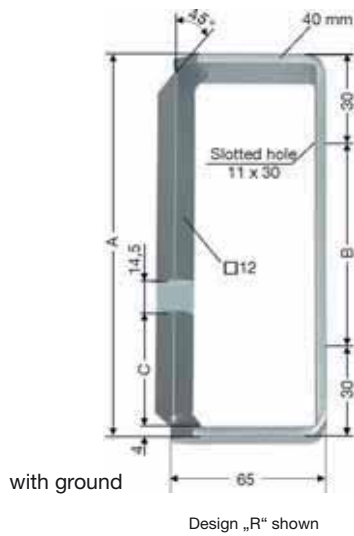

Type	A mm	B mm	C mm	Weight kg	Order-No.
UMA 12 HS-B- 6-14 L	108	48	50	0.39	780 184
UMA 12 HS-B- 6-14 R	108	48	50	0.39	780 183
UMA 12 HS-B- 7-14	122	62	50	0.42	780 181
UMA 12 HS-B- 8-14 L	136	76	50	0.46	780 180
UMA 12 HS-B- 8-14 R	136	76	50	0.46	780 179
UMA 12 HS-B- 9-14 L	150	90	50	0.49	780 178
UMA 12 HS-B- 9-14 R	150	90	50	0.49	780 177
UMA 12 HS-B-10-14 L	164	104	50	0.52	780 176
UMA 12 HS-B-10-14 R	164	104	50	0,52	780 175

Carbon brushes

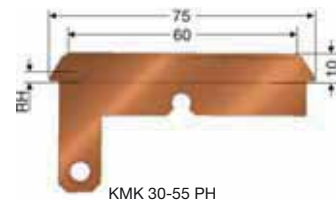

KMK 30-55 PH

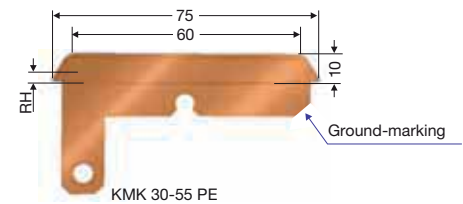

KMK 30-55 PE

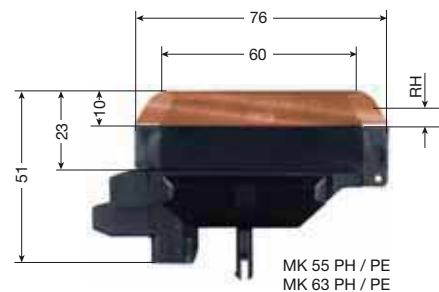

MK 55 PH / PE
MK 63 PH / PE

Type	For current collector	Carbon brush thickness	RH mm	Weight kg	Order-No.
KMK 30-55 PH	KST 30 - KST 55 and KSTU 30 - 55	4,40 mm	4,00	0,031	154 440
KMK 30-55 PE	KST 30 - KST 55 and KSTU 30 - 55	4,40 mm	4,00	0,031	154 453
MK 55 F/14.28	KESR 32 - 55F KESL 32 - 55F	4,20 mm	3,50	0,040	780 920
MK 63 S/14.28	KESR 32 - 63S KESL 32 - 63S	4,20 mm	3,50	0,046	780 921

Springs

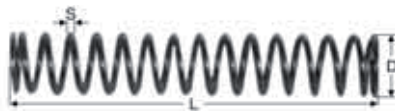

Pressure spring DF



Tension spring RF

Type	For current collector	S mm	D mm	L mm	Order-No.
DF 2	KESR 32-55	0.90	7.70	43.00	153 848
RF 3	KESR 32-55	0.40	4.40	31.00	153 849
VD	KESL 32-63	1,10	6,40	41,00	157 312

SUPPORT PROFILE FOR HIGH BAY STORAGE VKS 10



Accessories VKS 10

Type	Order-No.
Connector cap	780 137
Plug-in joint VKS 10/ 10- 60A	780 807
Plug-in joint VKS 10/ 100-120 A	780 808
Plug-in joint VKS 10/ 120-140 A	780 028
Connection bolts, complete for VLS 10/ 60 + 200-280	780 138
Connection bolts, complete for VLS 10/100-140	780 130
Connection bolts, complete for VNS 10/ 60-280	780 139
Plastik glue for tangential funnel DSEV 10	780 280

Support profile,

Length: 6 m

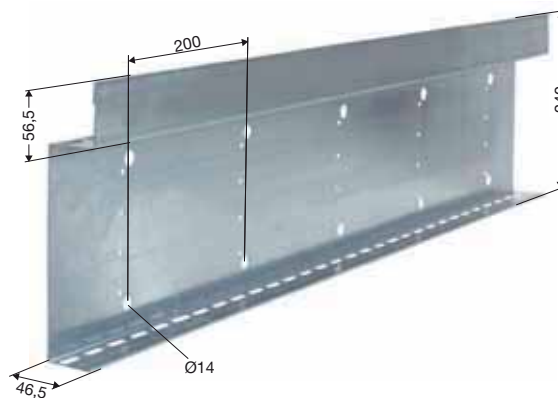

Type	Weight kg/m	Order-No.
VTP 10	4,300	781 006

Support profile VTP 10 for feed VNS 10, VLS 10

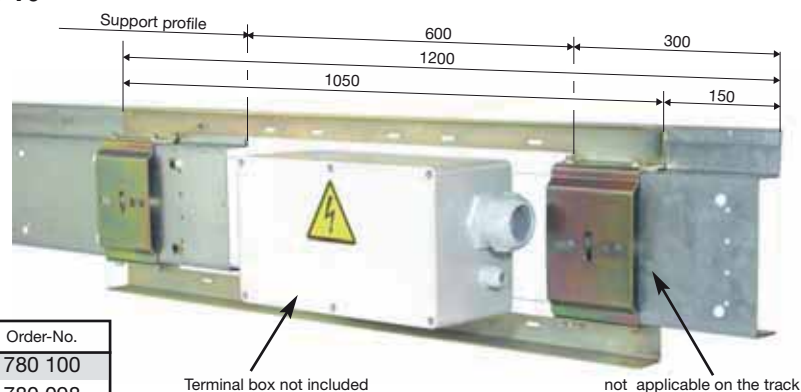

Type	Order-No.
Version for initial / end section	780 100
Version on the track	780 098

Connector

Only as single component otherwise included in the attachment material of the support profile.

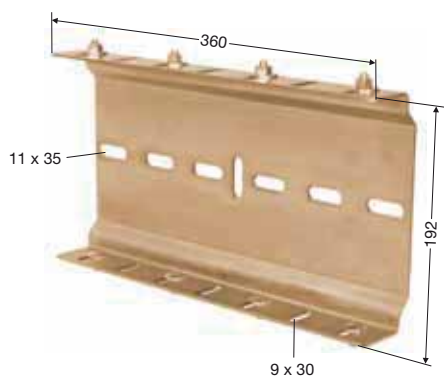

Type	Weight kg	Order-No.
VTPV 10	2.398	781 000

Hanger

Only as single component otherwise included in the attachment material of the support profile.

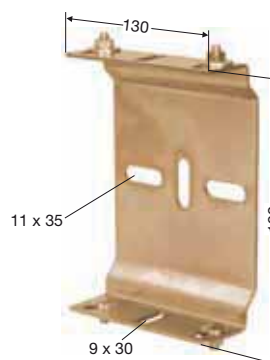

Type	Weight kg	Order-No.
VTPA 10	0.878	781 007



SUPPORT PROFILE ATTACHMENTS VKS 10

VTPB-P

Fig. 1

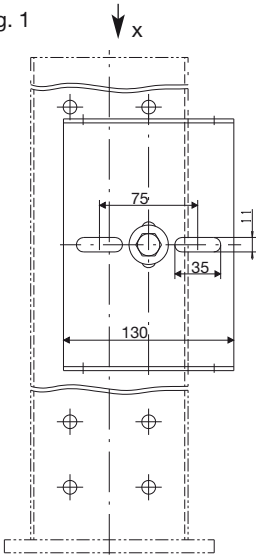

VTPB

Fig. 4

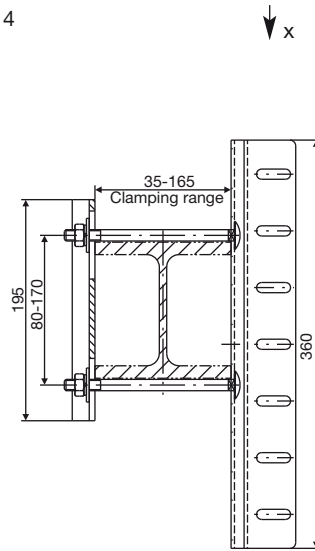

VTPB-SPR

Fig. 2

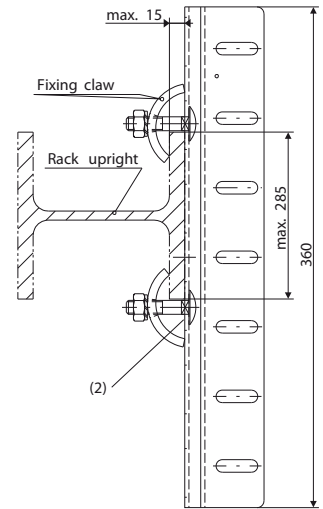

View x

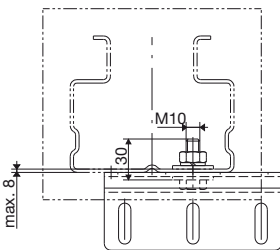

View y

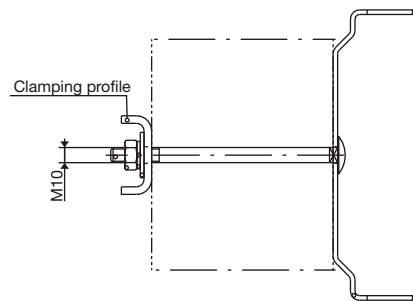

VTPB-SPW Fig. 3

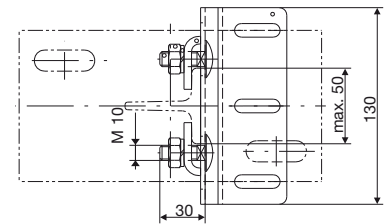

VTPB-S 1/2 Fig. 5

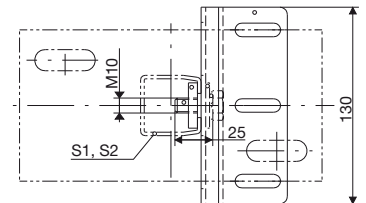

Type ⁽¹⁾	Fig.	Clamping range	Weight kg	Order-No.
VTPB-P	1	max. 8	0,938	780 147
VTPB-SPW	2	max. 15	2,674	780 148
VTPB-SPR	3	max. 15	1,066	780 149
VTPB 35 - 45	4	35 - 45	3,054	780 150
VTPB 45 - 55	4	45 - 55	3,062	780 151
VTPB 55 - 65	4	55 - 65	3,076	780 152
VTPB 65 - 75	4	65 - 75	3,084	780 153
VTPB 75 - 85	4	75 - 85	3,096	780 154
VTPB 85 - 95	4	85 - 95	3,102	780 155
VTPB 90 - 105	4	90 - 105	3,110	780 156
VTPB 100 - 115	4	100 - 115	3,118	780 157
VTPB 110 - 125	4	110 - 125	3,132	780 158
VTPB 120 - 135	4	120 - 135	3,144	780 159
VTPB 130 - 145	4	130 - 145	3,152	780 160
VTPB 140 - 155	4	140 - 155	3,164	780 161
VTPB 150 - 165	4	150 - 165	3,172	780 162
VTPB S 1/2	5	max. 8	0,944	780 163

⁽¹⁾ Bigger clamping range on request.

⁽²⁾ Locking torque of the round-head screw M 10, MA= 18 Nm

Operating principle

VAHLE-APOS® consists of a code strip with magnetic length coding and a reading head with integrated logic, which transmits the position to the control system via interface. The intelligent reading head determines the position from the code strip and evaluates it for downstream control systems for processing.



VAHLE-APOS® for pole 10th



VAHLE-APOS® for pole 11th

- absolute positioning identification upto 524 m
- retrofit
- absolute position at engaging or after a outage directly available
- safe position identification aswell with wetness or dust
- travel speed upto 6 m/s

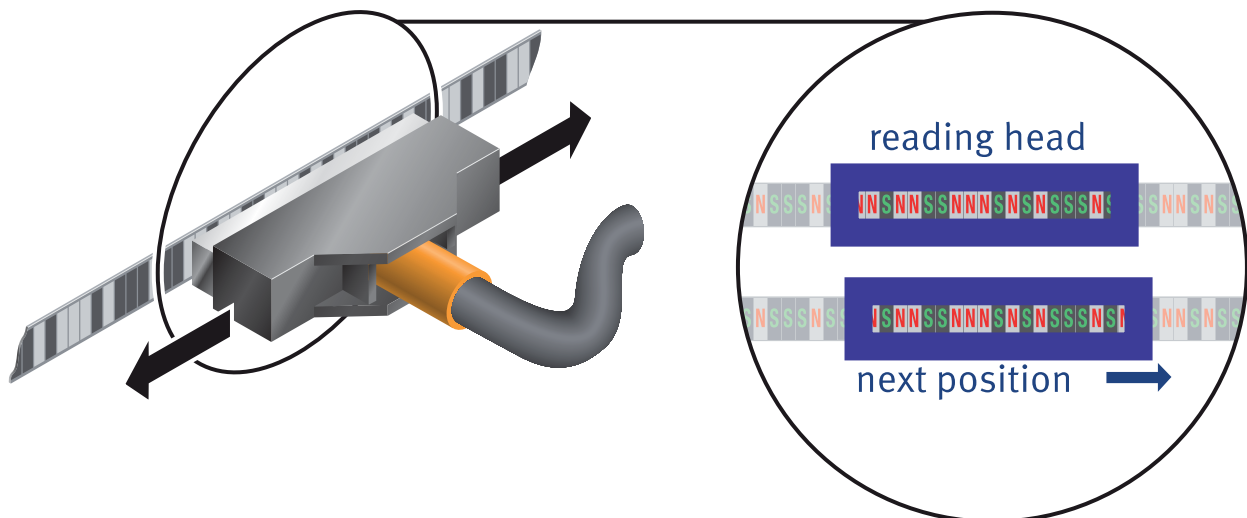

For further details please refer to APOS catalog (7a)



POSITIONING SYSTEM

Cost-efficient installation of different positioning systems

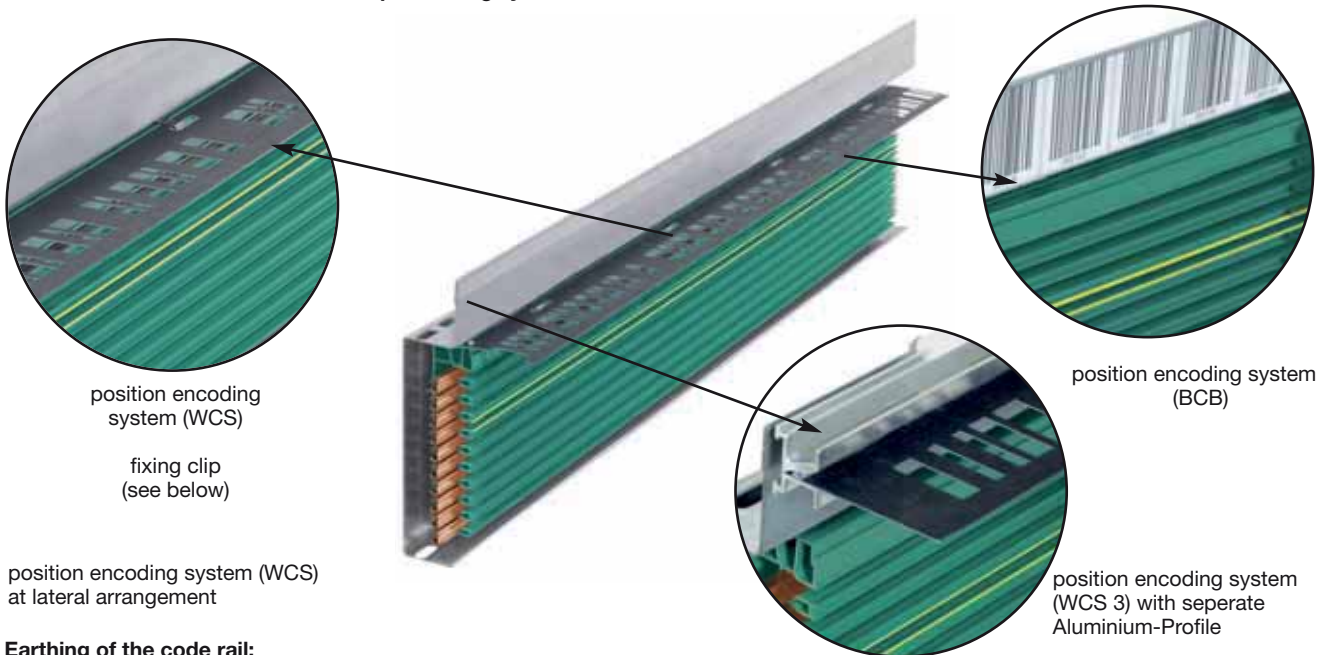

position encoding system (WCS) at lateral arrangement

Earthing of the code rail:

Connect the WCS code rail at least every 30 m to the potential of the system of low resistance. Part No. 302160.

Fixing clip

for laminate band



Fixing distance 0.2 m

Type	Weight kg	Order-No.
Fixing clip for plastic laminate band	0.002	780 193

Position encoding band

for WCS



WCS

1x per conductor section



BCB

Type	Weight kg/m	Order-No.
Plastic laminate band with special perforation (WCS 3)	0.040	302 106
Screws for fixation	0.001	780 140
Barcode band (BCB)	0.015	302 107

Installation tool For use with support profile



Type	Weight kg	Order-No.
Joint cap assembly tool	0.350	780 070

Installation tool For use with support profile



Type	Weight kg	Order-No.
Copper connector mounting lever	1.50	780 090

Installation comb

Type	Weight kg	Order-No.
Installation comb, set for VKS 10	0,230	781 112



To adjust the air gap at the joint

QUESTIONNAIRE



Company: _____ Date: _____

Tel: _____ Fax: _____

E-Mail: _____ Internet: (URL) _____

1. Number of powerail installations: _____

2. Type of equipment to be powered: _____

3. Operating voltage: _____ Volts, Phases: _____, Frequency: _____ Hz
Three phase voltage: AC voltage: DC voltage:

4. Track length: _____

5. Number of powerails: _____ (main rails: _____ control rails: _____ ground rail: _____)

6. Mounting position of powerail:

- Powerail resp. current collector laterally mounted
- Hanger interval _____ m
- Other: _____

7. Number of equipment on one powerail installation: _____

8. Indoor plant:

9. Other operating conditions (humidity, dust, chemical influence etc.)

10. Ambient temperature: _____ °C min. _____ °C max.

11. Position and number of feeds: _____

12. Position and number of isolated sections (e.g. for repair work): _____

13. How are the rails laid out? (Please provide sketch): _____

14. Travel speed: _____

15. Power consumption of the individual consumer loads: _____
(Please consult table on reverse side)

16. Max. voltage drop from the powerail feed to the consumer units:

3% or _____ % of the nominal voltage

Remarks: _____

For curved tracks, powerails with isolating sections etc., we require sketches to enable us to prepare a quotation. pto!



QUESTIONNAIRE

To the nearest local VAHLE agency:

Date:

Motor specification	Equipment 1						Equipment 2					
	Capacity kW	Nominal current			Start-up current		Capacity kW	Nominal current			Start-up current	
		A	$\cos\varphi_N$	% ED	A	$\cos\varphi_A$		A	$\cos\varphi_N$	% ED	A	$\cos\varphi_A$
Hoisting gear												
Running gear												

Motor specification	Equipment 3						Equipment 4					
	Capacity kW	Nominal current			Start-up current		Capacity kW	Nominal current			Start-up current	
		A	$\cos\varphi_N$	% ED	A	$\cos\varphi_A$		A	$\cos\varphi_N$	% ED	A	$\cos\varphi_A$
Hoisting gear												
Running gear												

Mark with * those motors which could run simultaneously.
 Mark with Δ those motors which could start up simultaneously.

Further information: e.g. type of motor (squirrel cage, slip-ring etc.)

Signature: _____



Products and Service	Catalog No.
1 Open conductor systems	
Open conductor systems	1a
2 Insulated conductor systems	
U 10	2a
FABA 100	2b
U 15 - U 25 - U 35	2c
U 20 - U 30 - U 40	2d
3 Compact conductor systems	
VKS 10	3a
VKS - VKL	3b
4 Enclosed conductor systems	
KBSL - KSL	4a
KBH	4b
MKLD - MKLF - MKLS	4c
LSV - LSVG	4d
5 Contactless power system	
Contactless power system (CPS®)	5a
6 Data transmission	
VAHLE Powercom®	6a
Slotted Microwave Guide (SMG)	6b
7 Positioning systems	
VAHLE APOS®	7a
8 Festoon systems and cables	
Festoon systems for □- tracks	8a
Festoon systems for flat cables on I- tracks	8b
Festoon systems for round flat cables on I- tracks	8c
Festoon systems for ◇- tracks	8d
Cables	8e
9 Reels	
Spring operated cable reels	9a
Motor powered cable reels	9b
10 Others	
Battery charging systems	10a
Heavy enclosed conductor systems	10b
Tender	10c
Contact wire	10d

Assemblies/Commissioning

Spare parts/Maintenance service



Products and Service	Catalog No.
1 Copperhead conductor systems	
Powerails	1a
2 Uni - pole insulated conductor systems	
U 10	2a
FABA 100	2b
U 15 - U 25 - U 35	2c
U 20 - U 30 - U 40	2d
3 Compact conductor systems	
VKS 10	3a
VKS - VKL	3b
4 Enclosed conductor systems	
KBSL - KSL - KSLT	4a
KBH	4b
MKLD - MKLF - MKLS	4c
LSV - LSVG	4d
5 Contactless Power System CPS®	
CPS® Contactless Power System	5a
6 Communication systems	
VAHLE Powercom®	6a
Slotted Microwave Guide (SMG)	6b
7 Position encoding systems	
VAHLE-APOS®	7a
8 Festoon systems	
Cable carriers for □ - tracks	8a
Cable carriers for flatform cables on I - beams	8b
Cable carriers for round cables on I - beams	8c
Cable carriers and accessories for ◇ - tracks	8d
Cables	8e
9 Reels	
Spring operated cable reels	9a
Motor powered cable reels	9b
10 Others	
Battery charging systems	10a
Heavy enclosed conductor systems	10b
Cable tenders	10c
Trolley wire and accessories	10d

Installations/Commissioning
Spare Parts/Maintenance Service



POWERAIL LTD.
WORKING FOR THE FUTURE WITH



Powerail Ltd. High Road, Finchley, London, N12 8PT,
Phone 020 8446 0350/1246 • Fax 020 8446 7054
E-mail: enquiries@powerailtd.com