

INSULATED CONDUCTOR SYSTEMS

U 20 – U 30 – U 40



INSULATED CONDUCTORS U 20 – U 30 – U 40

INDEX	U 20	U 30	U 40
	Page	Page	Page
Basic description	4	4	4
Conductors	5	20	30
Rigid joints	5	21	32
Expansion sections	6	21	32
Locating clamps	8	22	32
End caps	8	22	32
Feed terminals	6	22	33
Contact paste	6	22	32
Transfer guides	7	23	34
Transfer funnels	7	25	-
Sectionalizing	7	23	34
Hangers	9	24	35
Insulators	8	24	35
Rail holders	8	24	35
Compact hangers/Attachment hardware/Bracket profiles	9	25	-
Collectors	10-12	26	36
Components and spares for collectors	13-18	27-29	37
Examples for ordering	19	27	38
Grounding device	39	39	39
Questionnaire	40, 41	40, 41	40, 41
Typical installations	42	42	42





BASIC DESCRIPTION

Seite 4

U 20

For cranes, self-propelled monorail carriers, amusement rides – for installations with curves, switches, turntables, special control conductor systems for pickling lines and galvanizing plants

Pages 5–19

U 30

For bridge and portal crane electrification, heavy monorail systems, amusement rides, construction and maintenance hoists and for high voltage applications up to 10 kV

Pages 20 – 29

U 40

For heavy cranes and loading bridges, container and transtainer systems, coking machinery, for dockside trench type electrification systems in ports, shipyards and steel mills – for all heavy duty and for high voltage applications up to 10 kV

Pages 30 – 38

GROUNDING DEVICE

Page 39

QUESTIONNAIRE

Pages 40, 41

TYPICAL INSTALLATIONS

Seite 42



INSULATED CONDUCTORS U 20 – U 30 – U 40

General

VAHLE insulated conductors are designed in accordance to international safety regulations for a multitude of power supply applications. They fully meet VDE 0100 and are finger safe to EN 60529 (VDE 0470, part 1, protection code IP 23). They are UL, SAA and SEV approved.

For current collectors touch protection is only given if carbon brushes are fully entered into the conductors. Conductor installations in the reach of hand, where collectors leave the conductor rails during normal operation, must be protected against accidental touch by the customer e.g. switch-off or separation. This refers to voltages above 25 VAC resp. 60 VDC, only.

The adjacent picture demonstrates that the VDE test finger cannot reach live conductors – finger safety is guaranteed.

For high voltage applications we do recommend our adequate high voltage insulators but applicable international or local safety requirements have to be considered.

The shrouding which envelops the various conductors is an excellent insulator. Therefore our unipole insulated conductors guarantee utmost safety in operation.

The ground conductor is identified by international colour coding. For obvious safety reasons phase and ground collectors are not interchangeable.

Any number of conductors can be accomplished by installing various power rails side by side.

Standard rail sections are 6 m long, shorter lengths to coincide with your runway requirements are available.

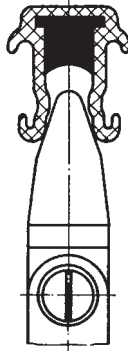

Approvals

U 20 and U 30: UL-approval

Please ask in case of order

Hangers

Support brackets will be prepared in accordance to your local requirements or provided by others considering your runway system configuration.

U 20: see page 5 - **U 30:** see page 20 - **U 40:** see page 30.

Insulators

The insulated conductor rails could be installed with insulators. Through this is the creepage distance longer. In systems with difficult ambient and environmental conditions (high humidity, electroplating shop, chemical industry etc.) are this insulators required.

Insulating covers

	Standard shrouding colour green	High temp. shrouding colour grey
Electrical properties:		
dielectric strength DIN 53 481	30-40 kV/mm	45 kV/mm
specific resistance DIN 53 482	5×10^{15} Ohm/cm	5×10^{17} Ohm/cm
Surface resistance according to IEC 60093	10^{13} Ohm	10^{15} Ohm
Creep resistance according to IEC 60112/ VDE 0303	CTI > 600-2,7	CTI > 600-2,7
Mechanical properties:		
flexible strength	75 N/mm ² ± 10%	95 N/mm ² ± 10%
tensile strength	50 N/mm ² ± 10%	50 N/mm ² ± 10%
Temperature resistance	-30 °C thru +55 °C	-30 °C thru +85 °C
flame test proof per DIN 4102 part 1	class B1 no flaming particles, self extinguishing	

Joints

The connection between the conductor rails is made through bolted joints.

For touch protection every joint will be covered through a joint cap. With bigger temperature fluctuation and length above 100 m are expansion sections required (see installation instructions).

Feed terminals

The feed will be installed between two conductor rails instead of a standard joint. To connect this feed please consider single core cables.

End caps

The end caps are the touch proof end of the conductor rails.

Entry funnel and transfer guides

For the use in spurlines, turntables and switches are transfer guides and entry funnels available.

Isolating sections

Isolating sections are electrical interrupts of the conductor. Under normal operating conditions a cross over with collectors to switch the voltage off or on is only allowed with low power ratings (control current).

For control reasons, feed tracks, repair areas etc. we supply isolating sections.

Curves

The insulated conductor rails could be bend in horizontal or vertical curves. The rails are depending on type and radius bend in our factory or on site.

Current collectors

Depend on usage single or double collectors are used.

The mentioned continuous currents are for collectors in standard use with conductor profiles with copper surface. With the AE-conductor rail the collectors of consumers which remain at one place continuously or work under a very low travel speed (e.g. 10/min.) the maximum continuous current is approx. 50% of the mentioned continuous current.

The length of the cable should not extend 3 m if the fuse is not laid out for this load capacity. (See aswell DIN VDE 0100, part 430 and DIN EN 60204)

Note: The a.m. Often occurs in systems with more than one collector)

The supplied connecting cables (H07RN-F) are for the mentioned nominal currents big enough. For the different cable layouts have the reduction factors of DIN VDE 0298 to be considered.

Safety advice

It must be ensured that the arrangement of the conductor system provides minimum distances (0,5 m) between fixed and mobile parts. (i.e. Between conductor rails, collector trolleys and towing arms) so as to avoid the risk of pinching.

Chemical resistance for both designs:

Shroudings in the standard design (color green) and in the heat resistant design (color grey) are resistance against mineral oil, fats, caustic soda 25%, caustic soda 50%, concentrated hydrochloric acid; sulfuric acid upto 50%.

Please note: For use in galvanizing and pickling plants, under aggressive conditions and low voltage applications we would appreciate receiving detailed information, especially of the environmental conditions.

For quotations and order processing including Powerail systems with curves, dead sections, turntables, switches etc. we require your drawings or sketches.

Type	U 20/50 CE	U 20/50 AC	U 20/50 C	U 20/50 CH
Weight kg/m	0,500	0,400	0,580	0,560
Standard shroud, color green				
Order- No. phase ⁽²⁾	12701 •	12702 •	12703 •	12704 •
Order- No. ground ⁽²⁾	12711 •	12712 •	12713 •	12714 •
High temperature shrouding, color gray				
Order- No. phase ⁽²⁾	12706 •	12707 •	12708 •	12709 •
Order- No. ground ⁽²⁾	12716 •	12717 •	12718 •	12719 •

Engineering data

Type	Conductor cross section mm ²			Leakage distance of shroud mm	Max. Voltage V	max. continuous ampere capacity A by 35 °C	Resistance Ohm/1000 m	Impedanz ⁽⁴⁾ Ohm/1000 m
	Cu	Al	Steel					
U 20/50 CE	30		18	45	1000	80	0,587	0,612
U 20/50 AC	18	30		45	1000	120	0,483	0,600
U 20/50 C	50			45	1000	210	0,376	0,416
U 20/50 CH	50			45	1000	210	0,376	0,416

Conductor code

U = Unipole insulated conductor
 20 = Shrou size
 50 = Cross sectional area (mm²)
 CE = Copper/stainless steel conductor
 AC = Aluminium/copper conductor
 C = Copper conductor
 CH = Copper conductor with extra deep groove for high speed application and lateral mounting

Conductor distance:

With insulated hangers: 50 mm
 With compact hangers 23-26 mm
 Chemical and electrical values aswell as temperature range see page 4

Supply lengths:

6 m standard; shorter lengths are available

Support spacing:

– for straight runs and lateral curves: 1000 mm
 – for horizontal curves $R_H < 5 \text{ m}^{(3)}$: 500 mm
 – for horizontal curves $R_H > 5 \text{ m}$: 1000 mm

Bending:

Factory fabricated min. R = 400 mm
 Field fabrication min. R = 2500 mm

Rigid joints

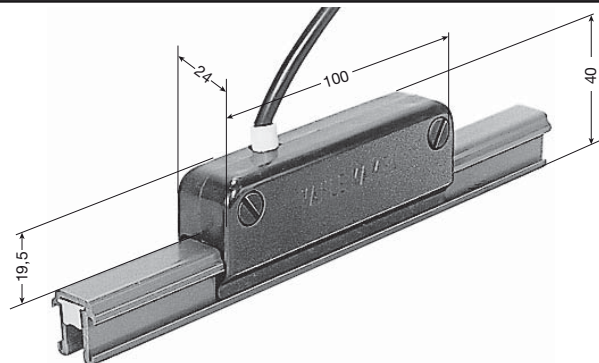
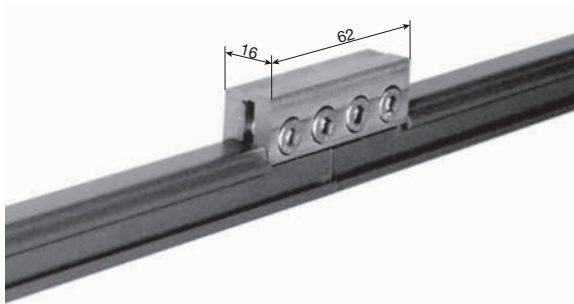

Type	for conductor				Weight kg	Order- No.
UV 20/50	U 20/50 AC	U 20/50 C	U 20/50 CH	U 20/50 CE	0,140	120 180
UV 20/50 K 4⁽¹⁾	U 20/50 AC	U 20/50 CE	U 20/50 CH	U 20/50 CE	0,140	126 504

⁽¹⁾ Stainless steel hardware

⁽²⁾ The last number of the order-no. Is the single length in meter. Please add 1,2 ... 6 in the end. Short length have to be rounded up.

⁽³⁾ Recommended

⁽⁴⁾ With frequency of 50 Hz.



ACCESSORIES FOR U 20

Expansion sections

Factory assembled on 1 m long conductor section incl. one joint splice. They are used in systems >100 m. The 1 m expansion assembly is part of the system length and has to be considered.

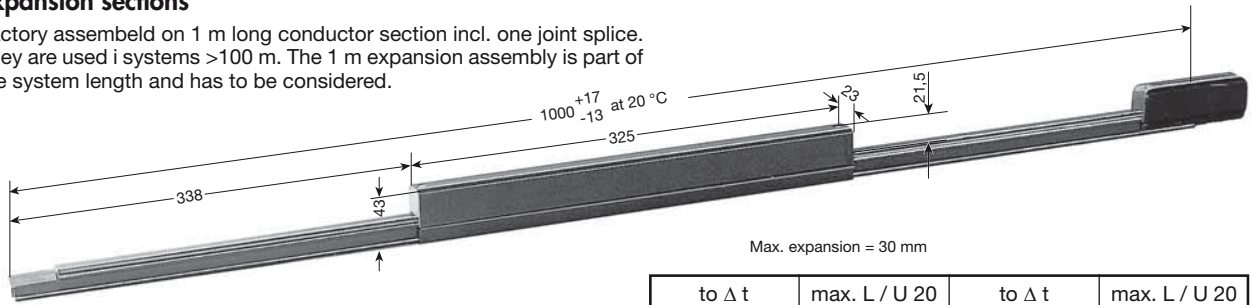

Ermittlung der Dehnungsteilstücke

n = Number of UDV (rounded)
 $n = \frac{L_1}{L}$ L₁ = Length of assembly minus 100 m
 L = Expansion capacity max. of UDV (see table)

to Δ t	max. L / U 20	to Δ t	max. L / U 20
20 °C	88 m	40 °C	44 m
30 °C	58 m	50 °C	35 m

Standard shrouding, color green

Type	Weight kg	Order- No.	
		phase	ground
UDV 20/50 CE K 4 ⁽¹⁾	0,622	126 514	126 515
UDV 20/50 AC K 4 ⁽¹⁾	0,622	126 516	126 517
UDV 20/50 C K 4 ⁽¹⁾	1,030	126 518	126 519
UDV 20/50 CH K 4 ⁽¹⁾	1,020	126 520	126 521

High temperature shrouding, color grey

Type	Weight kg	Order- No.	
		phase	ground
UDV 20/50 CE K 4 ⁽¹⁾	0,622	126 674	126 675
UDV 20/50 AC K 4 ⁽¹⁾	0,622	126 676	126 677
UDV 20/50 C K 4 ⁽¹⁾	1,030	126 678	126 679
UDV 20/50 CH K 4 ⁽¹⁾	1,020	126 680	126 681

Feed terminals

Type	Weight kg	Order- No.
UE 20/50 K4 ⁽¹⁾	0,290	126 522
UE 20/50 K 4 ⁽¹⁾ -M	0,290	121 459

To be used instead of rigid joints
 Feed cable: 2 of max. 50 mm²

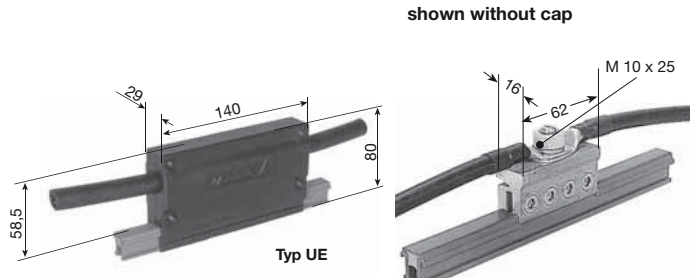

Type	Weight kg	Order- No.
UEN 20/50 K4 ⁽¹⁾ -A	0,120	126 526
UEN 20/50 K4 ⁽¹⁾ -A-M	0,120	121 061
UEN 20/50 K4 ⁽¹⁾ -B	0,120	120 116
UEN 20/50 K4 ⁽¹⁾ -B-M	0,120	212 165

Cannot be used as a rigid joint.
 Feed cable: 1 of max. 6 mm²

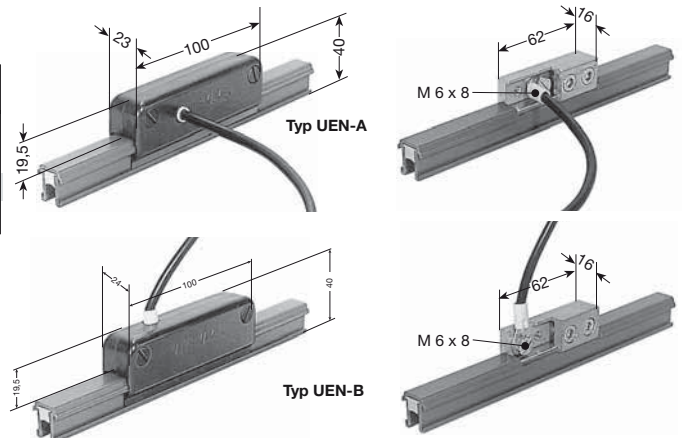

Type	Weight kg	Order- No.
UES 20/50 K 4 ⁽¹⁾	0,060	126 530

Cannot be used as a rigid joint.
 Feed cable: 1 of max. 4 mm²

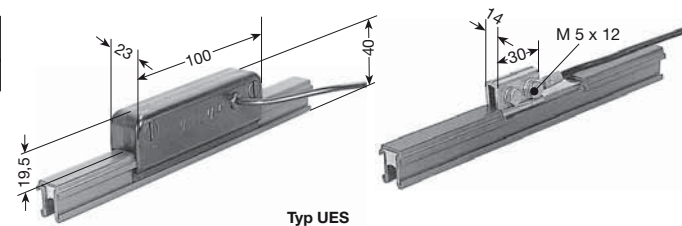

Contact Paste for joints and feeds

100 ml for approx. 200 joints	Order- No. 121 502
-------------------------------	--------------------



Transfer funnels

Transfer funnels are for spurlines, switches and turntables required.

With insulated hangers the type EM 20 in 1-6 pole design is used. For the layout of conductor rails in compact hangers is the type EMK 20 in 1-7 pole design available.

The conductor distance with insulated hangers is min. 40 mm and with compact arrangement 23-26 mm.

To prepare a quote please mention rail type, number of poles and position of PE.

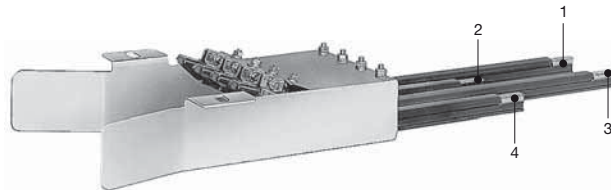

Picture shows Typ EM 20

Transfer guides

These guides serve for transfer or power interrupting-applications. Max. horizontal and vertical offset: ± 2 mm; gap between two transfer guides max. 8 mm.

Extra hangers are required and to be ordered separately.

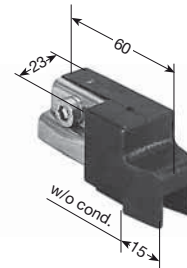

Type	for conductor	Weight kg	Order- No.
US 20/50 CH K 4⁽¹⁾	U 20/50 CH	0,046	120 849
US 20/50 C K 4⁽¹⁾	U 20/50 C	0,046	120 848
US 20/50 A K 4⁽¹⁾	U 20/50 AC U 20/50 CE	0,046	120 847

Transfer guides US 20 are fastened to conductor ends by means of one nylon screw.

Isolating sections

Type M: Factory assembled per system layout

Type L: Loose, incl. 2 locking pins 3 x 10

On both sides a hanger has to be considered.

Use one extra hanger each side, max. 200 mm away for stability.

Collectors, hangers and feeds have to be ordered separately.

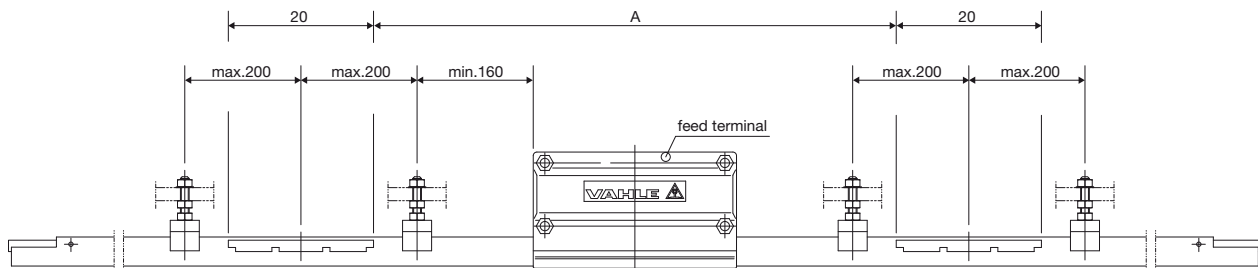
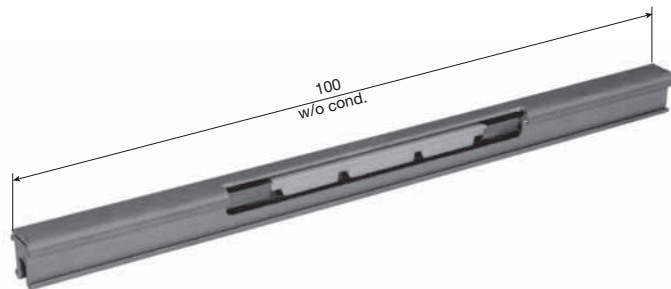

To avoid voltage by-pass by carbon brushes and to separate maintenance bays, control and main feed sections, double isolating sections are recommended.

Dim. A depends on type and number of current collectors and stopping distance of the crane.

Type	for conductor	Weight kg	Order- No.
IT/U 20/50 CH-M	U 20/50 CH	0,005	120 950
IT/U 20/50 C-M	U 20/50 C	0,005	120 940
IT/U 20/50 A-M	U 20/50 AC U 20/50 CE	0,005	126 536

Type	for conductor	Weight kg	Order- No.
IT/U 20/50 CH-L	U 20/50 CH	0,005	120 010
IT/U 20/50 C-L	U 20/50 C	0,005	120 009
IT/U 20/50 A-L	U 20/50 AC U 20/50 CE	0,005	120 008

⁽¹⁾ Stainless steel hardware



ACCESSORIES FOR U 20

Locating clamp

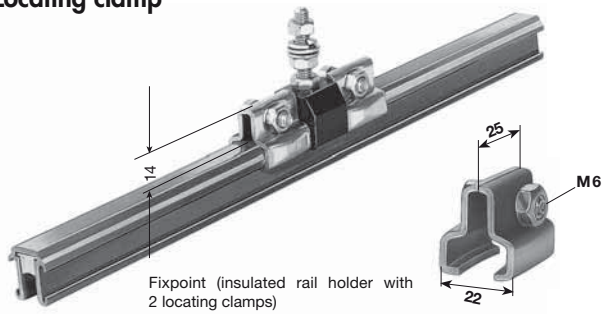

Type	Weight kg	Order- No.
USK 20 K 4 ⁽¹⁾	0,028	120 140

Insulated hangers⁽²⁾

Type	A
U20/50 CH	33
U20/50 C	34
U20/50 AC	35
U20/50 CE	35

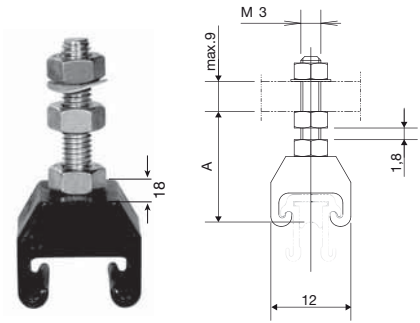

Type	Weight kg	Order- No.
UAM 20	0,025	126 540
UAM 20 K 4 ⁽¹⁾	0,025	126 542

Insulator⁽²⁾

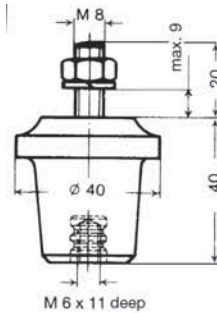

Cantilever strength = 3000 N
Leakage distance = 60 mm

Type	Weight kg	Order- No.
GH 40-M 6	0,075	121 060
GH 40-M 6 K 4 ⁽¹⁾	0,075	126 544

Insulator⁽²⁾ for aggressive mediums

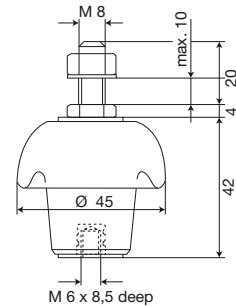

cantilever strength = 1000 N
Leakage distance = 62 mm

Type	Weight kg	Order- No.
UIK 42-M 6 K 4 ⁽¹⁾	0,110	120 883

Rail holder for insulators

for conductor rails U20/50 CH, 20/50 C, U20/50 AC and U20/50 CE

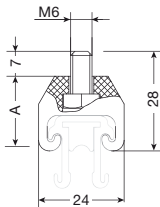

Type	A
U20/50 CH	20
U20/50 C	21
U20/50 AC	22
U20/50 CE	22

Supplied with bolt M 6 x 12

Type	Weight kg	Order- No.
UAK 20	0,010	126 546
UAK 20 K 4 ⁽¹⁾	0,010	126 548

for conductor rails U 20/50 CH, 20/50 C, U 20/50 AC and U 20/50 CE

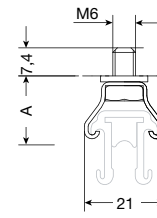

Type	A
U20/50 CH	17
U20/50 C	18
U20/50 AC	19
U20/50 CE	19

Supplied with bolt M 6 x 10 and spring washer

Type	Weight kg	Order- No.
UAS 20 K 4 ⁽¹⁾	0,014	126 550
UAS 20 K 4 ⁽¹⁾ -H ⁽³⁾	0,014	120 755

End caps incl. Locking pin

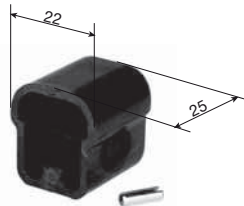

Type	Weight kg	Order- No.
UK 20-L	0,010	120 120
UK 20-M	0,010	120 987

Securing element for compact hangers KH 20/5....

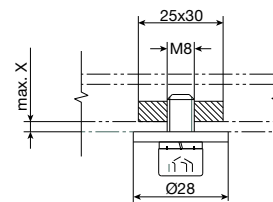

Type	Weight kg	Order- No.
SE 8	0,055	170 677
SE 8 K 4 ⁽¹⁾	0,055	170 955

⁽¹⁾ Stainless steel hardware

⁽²⁾ For installation in slotted holes use on both sides discs according to DIN 9021.

⁽³⁾ For aggressive mediums



Any number of conductors poles can be assembled with compact hangers.
Can only be used with collectors of type KST. The joints and feeds have to be arranged staggered.

Compact hangers, 5 poles to be bolted ⁽²⁾

Type	A
U20/50 CH	41
U20/50 C	42
U20/50 AC	43
U20/50 CE	43

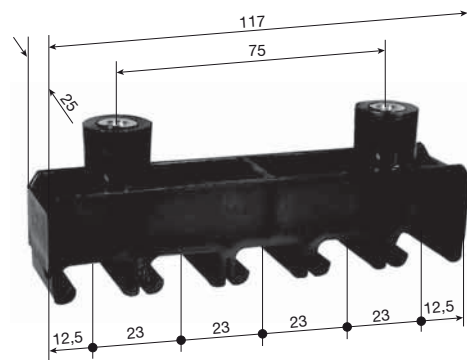
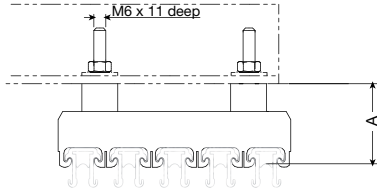

Type	Weight kg	Order- No.
KA 20/5	0,041	126 613

Compact hangers for bracket profiles 38/17 G

Typ	A
U20/50 CH	23
U20/50 C	24
U20/50 AC	25
U20/50 CE	25

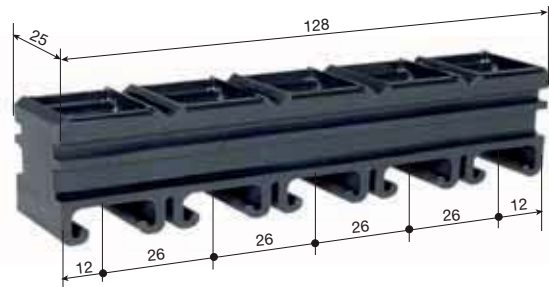

Type	B	Weight kg	Order- No.
KH 20/5-1	24	0,008	120 933
KH 20/5-2	50	0,018	120 934
KH 20/5-3	76	0,028	126 614
KH 20/5-4	102	0,038	126 615
KH 20/5-5	128	0,048	126 616

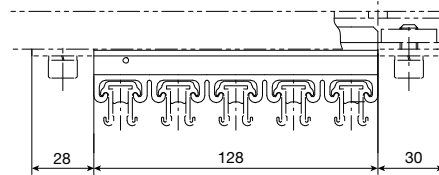

Attachment hardware for compact hangers, insulated hangers and insulators

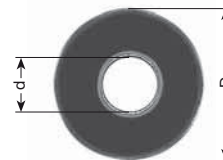
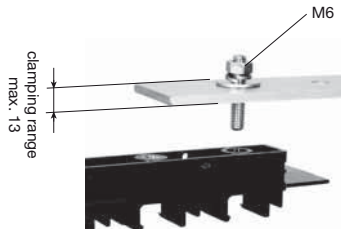

for 1 KA 20/5 are 2 pcs. BE 6 required.

Type	Weight kg	Order- No.
BE 6	0,015	120 406
BE 6 K 4 ⁽¹⁾	0,015	120 778

Type	Thread	d mm	D mm	S mm	Weight kg	Order- No.
Washer 6,4	M 6	6,4	18	1,6	0,003	120 776
Washer 6,4 K 4 ⁽¹⁾	M 6	6,4	18	1,6	0,003	120 777

Bracket profiles 38/17

incl. locking hardware

Type	Length mm	max. poles	Weight kg	Order- No.
HU 20/230	230	5	0,520	120 833
HU 20/360	360	10	0,750	120 834
HU 20/490	490	15	0,970	120 835

Longer Bracket profiles on request.

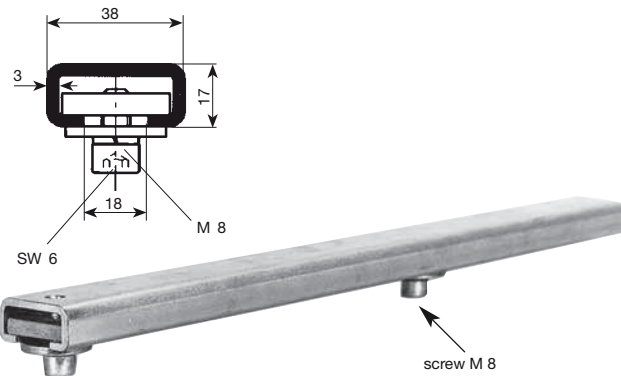

⁽¹⁾ Stainless steel hardware.

⁽²⁾ For installation in slotted holes use on both sided discs according to DIN 9021.



CURRENT COLLECTORS FOR U 20

Current collectors

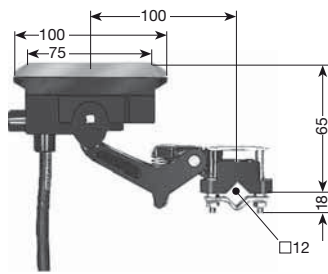

with 2 m connecting cable
lift and swivel ± 20 mm
contact pressure: approx. 9 N

Double collectors

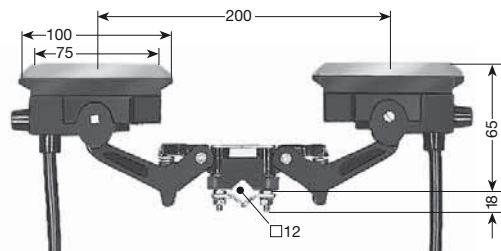

with 2 x 2 m connecting cable
lift and swivel ± 20 mm
contact pressure: approx. 9 N per Brush

Type ⁽¹⁾	Am- pacity A	Connecting cable		Weight kg	Order- No.		Type ⁽¹⁾	Am- pacity A	Connecting cable		Weight kg	Order- No.	
		mm ²	ø max/ mm		phase black	ground yellow			mm ²	ø max/ mm		phase black	ground yellow
KST 15	15	2,5	4,4	0,256	150 891	150 892	KDST 30	30	2,5	4,4	0,471	150 897	150 898
KST 40	40	6,0	11,0	0,428	152 840	152 850	KDST 80	80	6,0	11,0	0,821	152 960	152 970
KST 60	60	10,0	12,5	0,588	153 675	153 676	KDST 120	120	10,0	12,5	1,114	153 679	153 680

Current collectors

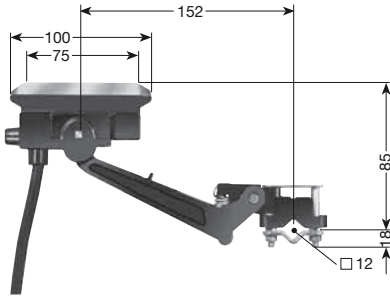

with 2 m connecting cable
lift and swivel ± 40 mm
contact pressure: approx. 9 N

Double collectors

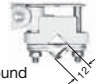
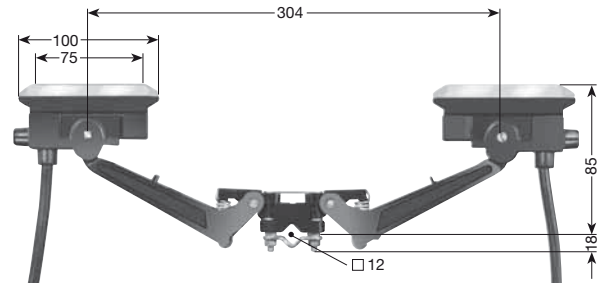

with 2 x 2 m connecting cable
lift and swivel ± 40 mm
contact pressure: approx. 9 N per brush

Type ⁽¹⁾	Am- pacity A	Connecting cable		Weight kg	Order- No.		Type ⁽¹⁾	Am- pacity A	Connecting cable		Weight kg	Order- No.	
		mm ²	ø max/ mm		phase black	ground yellow			mm ²	ø max/ mm		phase black	ground yellow
KSTL 15	15	2,5	4,4	0,272	150 893	150 894	KDSTL 30	30	2,5	4,4	0,492	150 899	150 901
KSTL 40	40	6,0	11,0	0,453	152 860	152 870	KDSTL 80	80	6,0	11,0	0,822	152 980	152 990
KSTL 60	60	10,0	12,5	0,591	153 677	153 678	KDSTL 120	120	10,0	12,5	1,188	153 681	153 682

Current collectors for transfer funnels EMK 20⁽¹⁾

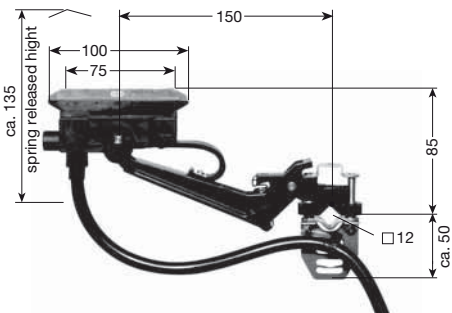

with 2 m connecting cable
lift ± 20 mm
swivel ± 40 mm
contact pressure: approx. 9 N

Double collectors for transfer funnels EMK 20⁽¹⁾

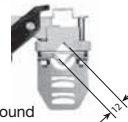
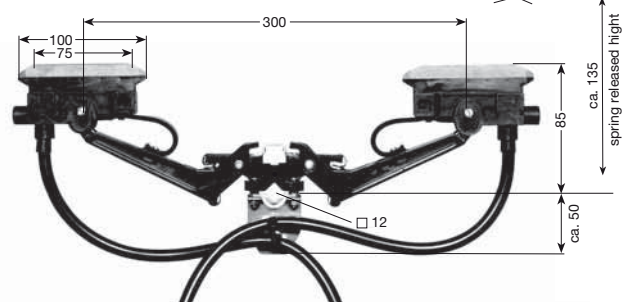

with 2 x 2 m connecting cable
lift ± 20 mm
swivel ± 40 mm
contact pressure: approx. 9 N per brush

Type ⁽¹⁾	Am- pacity A	Connecting cable		Weight kg	Order- No.		Type ⁽¹⁾	Am- pacity A	Connecting cable		Weight kg	Order- No.	
		mm ²	ø max/ mm		phase black	ground yellow			mm ²	ø max/ mm		phase black	ground yellow
KSTLU 15	15	2,5	4,4	0,313	150 895	150 896	KDSTLU 30	30	2,5	4,4	0,541	150 902	150 903
KSTLU 40	40	6,0	11,0	0,499	153 791	153 792	KDSTLU 80	80	6,0	11,0	0,895	153 786	153 787
KSTLU 60	60	10,0	12,5	0,652	153 793	153 794	KDSTLU 120	120	10,0	12,5	1,231	153 795	153 796

⁽¹⁾ Suffix types e.g. KST 15 \rightarrow KST 15 PH Order- No. 150 891

⁽²⁾ Collectors locate in unstressed condition automatic to phase center.
Amcapacity while using stainless steel conductors on request.



Current collectors

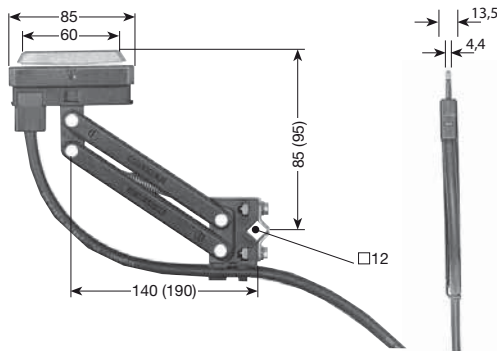

Type	Am- pacity A	Connecting-Cable		lift & swivel mm	Weight kg	Order- No.	
		mm ²	ø max/ mm			phase black	ground yellow
KST 30	30	2,5	5	± 20	0,240	152 085	152 086
KST 55	55	6,0	11	± 20	0,368	154 438	154 439
KSTL 30	30	2,5	5	± 30	0,240	152 089	152 091
KSTL 55	55	6,0	11	± 30	0,368	154 443	154 444

Dimensions in parenthesis for KSTL

with 2 m connecting cable
contact pressure: approx. 5 N

Current collectors⁽¹⁾

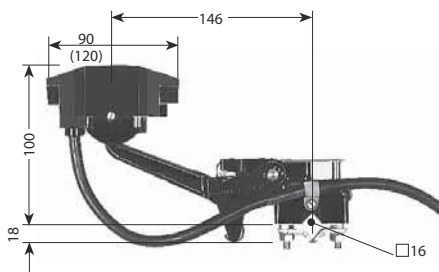

with 2 m connecting cable
lift ± 25 mm
swivel ± 25 mm
contact pressure: approx. 10 N

Double collectors⁽¹⁾

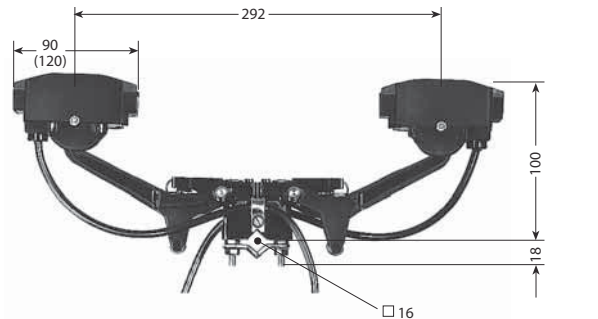

with 2 x 2 m connecting cable
lift ± 25 mm
swivel ± 25 mm
contact pressure: approx. 10 N per brush

Type	Am- pacity A	Connecting-Cable		Weight kg	Order- No.		Type	Am- pacity A	Connecting-Cable		Weight kg	Order- No.	
		mm ²	ø max/ mm		phase black	ground yellow			mm ²	ø max/ mm		phase black	ground yellow
UST 40	40	6	11,0	0,605	120 961	120 962	UDST 80	80	6	11,0	1,100	120 965	120 966
UST 60	60	10	12,5	0,875	120 963	120 964	UDST 120	120	10	12,5	1,600	120 967	120 968

Dimension in parenthesis for UST 60

Dimension in parenthesis for UDST 120

Current collectors for transfer funnels EM⁽¹⁾

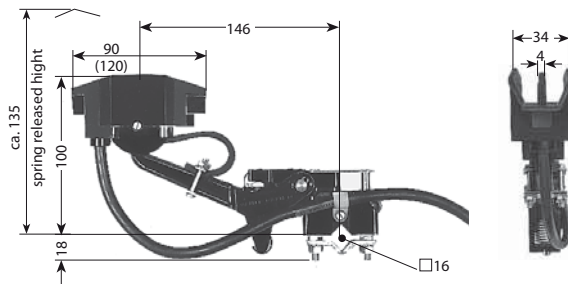

with 2 m connecting cable
lift ± 25 mm
swivel ± 25 mm
contact pressure: approx. 10 N

Double collector for transfer funnels EM⁽¹⁾

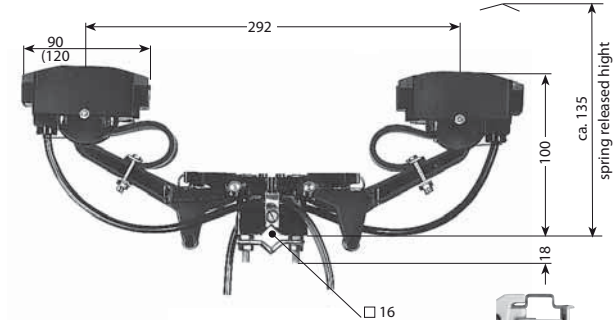

with 2 x 2 m Connecting cable
lift ± 25 mm
swivel ± 25 mm
contact pressure: approx. 10 N per Brush

Type	Am- pacity A	Connecting-Cable		Weight kg	Order- No.		Type	Am- pacity A	Connecting-Cable		Weight kg	Order- No.	
		mm ²	ø max/ mm		phase black	ground yellow			mm ²	ø max/ mm		phase black	ground yellow
USTU 40	40	6	11,0	0,635	120 969	120 970	UDSTU 80	80	6	11,0	1,160	120 973	120 974
USTU 60	60	10	12,5	0,815	120 971	120 972	UDSTU 120	120	10	12,5	1,550	120 975	120 976

Dimension in parenthesis for USTU 60

Dimension in parenthesis for UDSTU 120

⁽¹⁾ Collectors UST -UDST and USTU - UDSTU only for 35 mm phase distance.
Amcapacity while using stainless steel conductors on request.



CURRENT COLLECTORS FOR U 20

Use in aggressive mediums like pickling plants, galvanizing plants and galvanic systems.

Current collectors phase⁽¹⁾

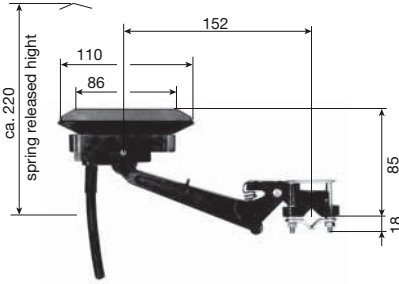

with 2 m connecting cable
lift +30 mm / -40 mm
swivel \pm 35 mm
contact pressure: approx. 9 N

Double collectors phase⁽¹⁾

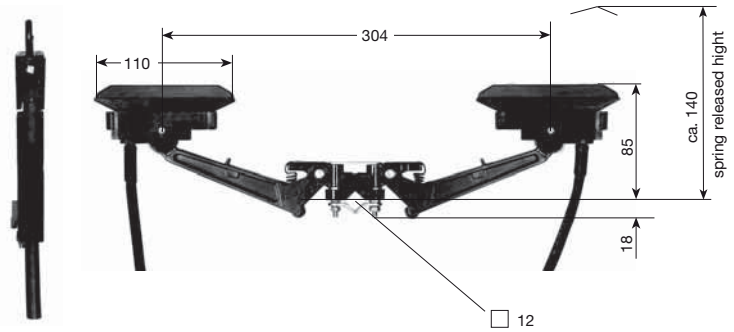

with 2 m connecting cable
lift +30 mm / -40 mm
swivel \pm 35 mm
contact pressure: approx. 9 N per brush

Type ⁽¹⁾	Am- pacity A	Connecting cable		Weight kg	Order- No. phase black
		mm ²	ϕ max/ mm		
KSTL 35 VB PH	35	6,0	11,0	0,410	121 186
KDSTL 70 VB PH	70	6,0	11,0	0,750	121 188

Current collectors, ground⁽²⁾

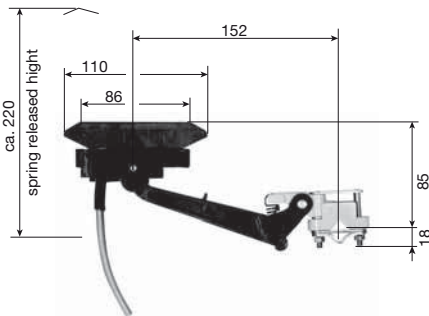

with 2 m connecting cable
lift +30 mm / -40 mm
swivel \pm 35 mm
contact pressure: approx. 9 N

Double collectors, ground⁽²⁾

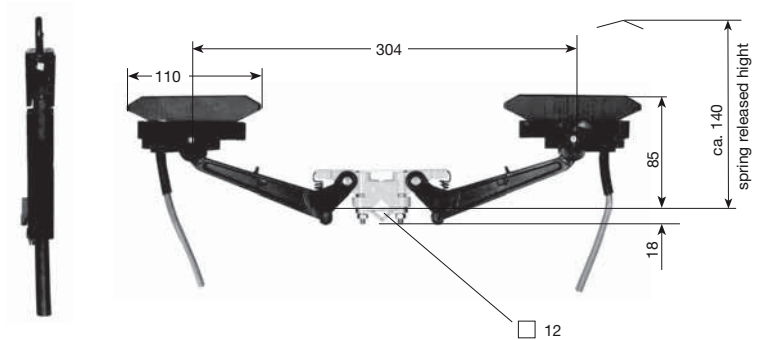

with 2 m connecting cable
lift +30 mm / -40 mm
swivel \pm 35 mm
contact pressure: approx. 9 N per brush

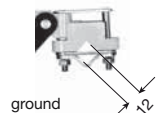

Type ⁽¹⁾	Am- pacity A	Connecting cable		Weight kg	Order- No. phase black
		mm ²	ϕ max/ mm		
KSTL 35 V PE	35	6,0	6,0	0,328	121 187
KDSTL 70 V PE	70	6,0	6,0	0,554	121 189



Collector bracket for KST and UST

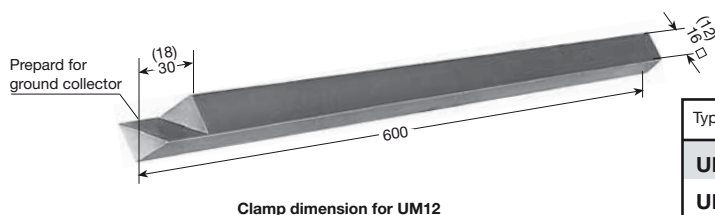

Type	Weight kg	Order- No.
UM 12 (for KST)	0,675	153 506
UM 12 K4⁽¹⁾ (for KST..V)	0,688	121 162
UM 16 (for UST)	1,175	126 574

With a length above 600 mm for the towing arm a support have to be considered on site to prevent bending or twisting.

Longer length are available.

Collector brackets

for current collectors
KST / KDST see page 10

for current collectors
KST see page 10

for control collectors
KST / KDST

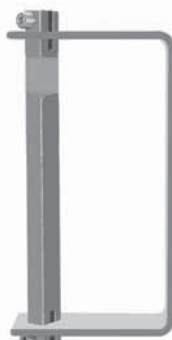
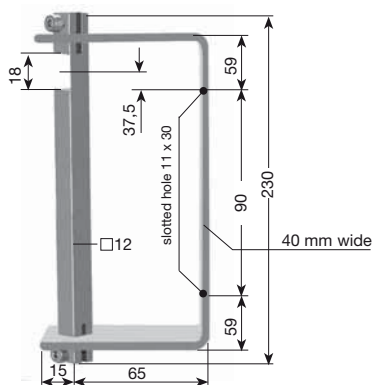

Type	Weight kg	Order- No.
UMAS 12 HS-A 200	0,740	121 092

Type	Weight kg	Order- No.
UMAS 12 HS-B 200	0,740	121 093

Type	Weight kg	Order- No.
UMAS 12 ST 200	0,740	121 094

Suitable for phase distance of max. 55 mm (3 pole + ground).

Tension springs

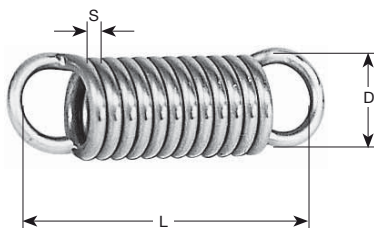

Type	for current collectors	Weight kg	S mm	D mm	L mm	Order- No.
ZF 3	KST 15 thru KDST 120	0,003	1,1	10,8	28,5	153 516
ZF 4	KSTL 15 thru KDSTL 120 and KSTLU 15 thru KDSTLU 120	0,004	1,3	11,0	29,0	153 517
ZF 4H	KSTL 35 thru KDSTL 70	0,004	1,3	11,0	29,0	170 601
ZF 5	UST 40, USTU 40, UDST 80, UDSTU 80 UST 60, USTU 60, UDST 120, UDSTU 120	0,007	1,5	13,8	40,0	126 585

⁽¹⁾ Stainless steel hardware.



COLLECTOR COMPONENTS U 20

Copper-graphite brushes

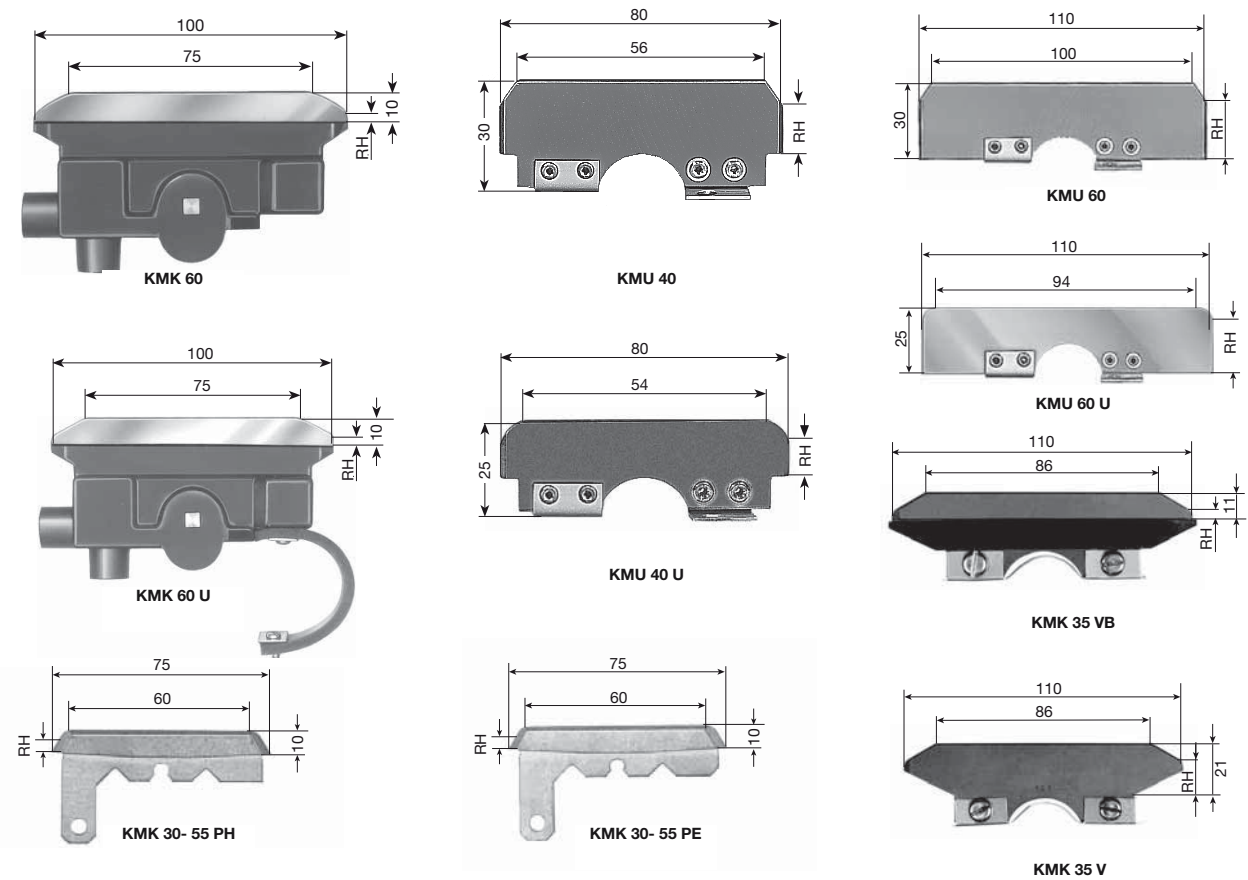

Dim H: max. wear for U 20/50 C

Type	for current collectors	RH mm	Weight kg	Order- No.
KMK 60	KST 15, KST 40, KDST 30, KDST 80, KSTL 15, KSTL 40, KDSTL 30, KDSTL 80, KST 60, KDST 120, KSTL 60, KDSTL 120	3	0,110	153 512
KMK 60 U	KSTLU 15, KSTLU 40, KSTLU 60, KDSTLU 30, KDSTLU 80, KDSTLU 120	3	0,115	153 513
KMU 40	UST 40, UDST 80	12	0,060	126 579
KMU 40 U	USTU 40, UDSTU 80	12	0,050	126 696
KMU 60	UST 60, UDST 120	18	0,070	126 581
KMU 60 U	USTU 60, UDSTU 120	18	0,060	126 743
KMK 30-55, phase	KST 30, KST 55, KSTL 30, KSTL 55	2	0,031	154 440
KMK 30-55, ground	KST 30, KST 55, KSTL 30, KSTL 55	2	0,031	154 453
KMK 35 VB, phase	KSTL 35 VB, KDSTL 70 VB	5	0,030	121 063
KMK 35 V, ground	KSTL 35 V, KDSTL 70 V	15	0,030	121 062

Cable attachment clamp

for current collectors Type KSTLU, KDSTLU

Type	Weight kg	Order- No.
KBK⁽¹⁾	0,030	153 519





Collectors of type KST, KSTL, KDST, KDSTL, KSTLU and KDSTLU

Part-No.	Description	Weight kg	Order- No.
1	Collector base for KST 15 thru KST 60	phase ground	153 736
2	Collector base for KST 15 thru KST 60		153 737
3	Collector base for KDST 30 thru KDST 120 (double arm)	phase ground	153 738
4	Collector base for KDST 30 thru KDST 120 (double arm)		153 739
5	Collector base for KSTL 15 thru KSTL 60	phase ground	153 740
6	Collector base for KSTL 15 thru KSTL 60		153 741
7	Collector base for KDSTL 30 thru KDSTL 120 (double arm)	phase ground	153 742
8	Collector base for KDSTL 30 thru KDSTL 120 (double arm)		153 743
9	Collector base for KSTLU 15 thru KSTLU 60	phase ground	153 804
10	Collector base for KSTLU 15 thru KSTLU 60		153 805
11	Collector base for KDSTLU 30 thru KDSTLU 120 (double arm)	phase ground	153 806
12	Collector base for KDSTLU 30 thru KDSTLU 120 (double arm)		153 807
13	Connecting cable AEA 2,5 PH / AEA-KSTLU-2,5 PH, 2 m long	phase ground	151 374 / 156 431
	Connecting cable AEA 2,5 PH / AEA-KSTLU-2,5 PH, 2 m long		151 375 / 156 432
13	Connecting cable AEA 6 PH / AEA-KSTLU-6 PH, 2 m long	phase ground	153 744 / 156 433
	Connecting cable AEA 6 PH / AEA-KSTLU-6 PH, 2 m long		153 745 / 156 434
13	Connecting cable AEA 10 PH / AEA-KSTLU-10 PH, 2 m long	phase ground	153 746 / 156 427
	Connecting cable AEA 10 PE / AEA-KSTLU-10 PH, 2 m long		153 747 / 156 435
14	Rubber spring ⁽¹⁾ for KSTLU 15, KSTLU 40, KDSTLU 30, KDSTLU 80, KDSTLU 120	0,008	153 748



⁽¹⁾ Rubber spring will be included when ordering KMK 60 U brush.



COLLECTOR COMPONENTS FOR U 20

Collectors of type KST 30-55 upto KSTL 30-55

Part.-No.	Description		Weight kg	Order- No.
1	Brush	phase	0,031	154 440
2	Brush	ground	0,031	154 453
3	Collector base & arm KST, complete	phase	0,083	152 275
3	Collector base & arm KST, complete	phase	0,083	152 279
4	Collector base & arm KST, complete	ground	0,083	152 276
4	Collector base & arm KST, complete	ground	0,083	152 281
5	Terminal cap	phase (black)	0,002	152 291
6	Terminal cap	ground (green)	0,002	152 292
7	Connecting cable RKA 2,5 PH, 2 m long	phase	0,150	154 447
	Connecting cable RKA 2,5 PH, 2 m long	ground	0,150	154 448
7	Connecting cable RKA 6 PH, 2 m long	phase	0,260	154 449
	Connecting cable RKA 6 PE, 2 m long	ground	0,260	154 450
8	Terminal bolt		0,002	152 658

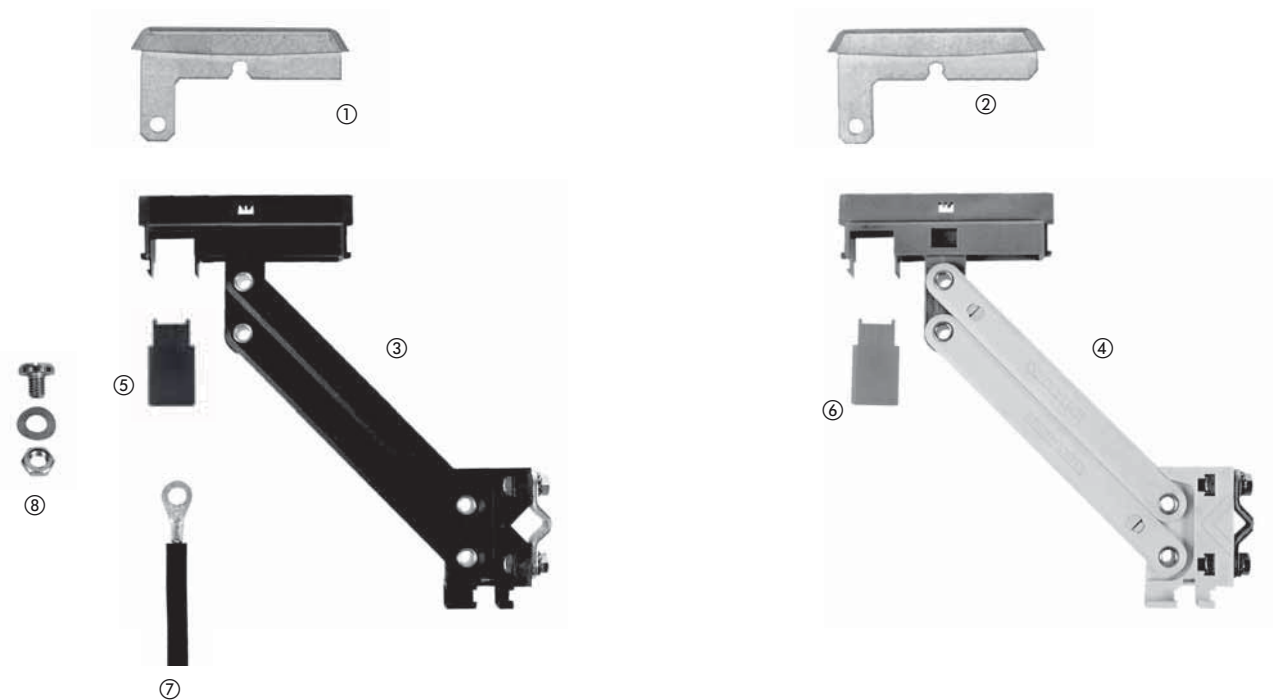



Collectors of type UST and UDST

Teil-Nr.	Artikel		Weight kg	Order- No.
1	Brush (see page 14)			
2	Brush holder for UST 40, UDST 80, USTU 40, UDSTU 80		0,050	120 949
2	Brush holder for UST 60, UDST 120, USTU 60, UDSTU 120		0,070	120 941
3	Collector base for UST 40, UST 60	phase	0,180	126 604
4		ground		126 605
3	Collector base for UDST 80, UDST 120	phase	0,250	126 692
4		ground		126 693
3	Collector base for USTU 40, USTU 60	phase	0,180	126 606
4		ground		126 607
3	Collector base for UDSTU 80, UDSTU 120	phase	0,250	126 694
4		ground		126 695
5	Connecting cable 6 mm ² , 2 m long, for UST 40, USTU 40, UDST 80, UDSTU 80	phase	0,300	120 948
		ground		120 952
5	Connecting cable 10 mm ² , 2 m long, for UST 60, USTU 60, UDST 120, UDSTU 120	phase	0,445	120 939
		ground		120943
6	Connecting piece		0,030	120 946
7	Current bridge		0,010	120 947
8	Rubber spring complete for USTU 40, UDSTU 80, USTU 60, UDSTU 120		0,008	126 612
9	Tension spring ZF 5		0,007	126 585

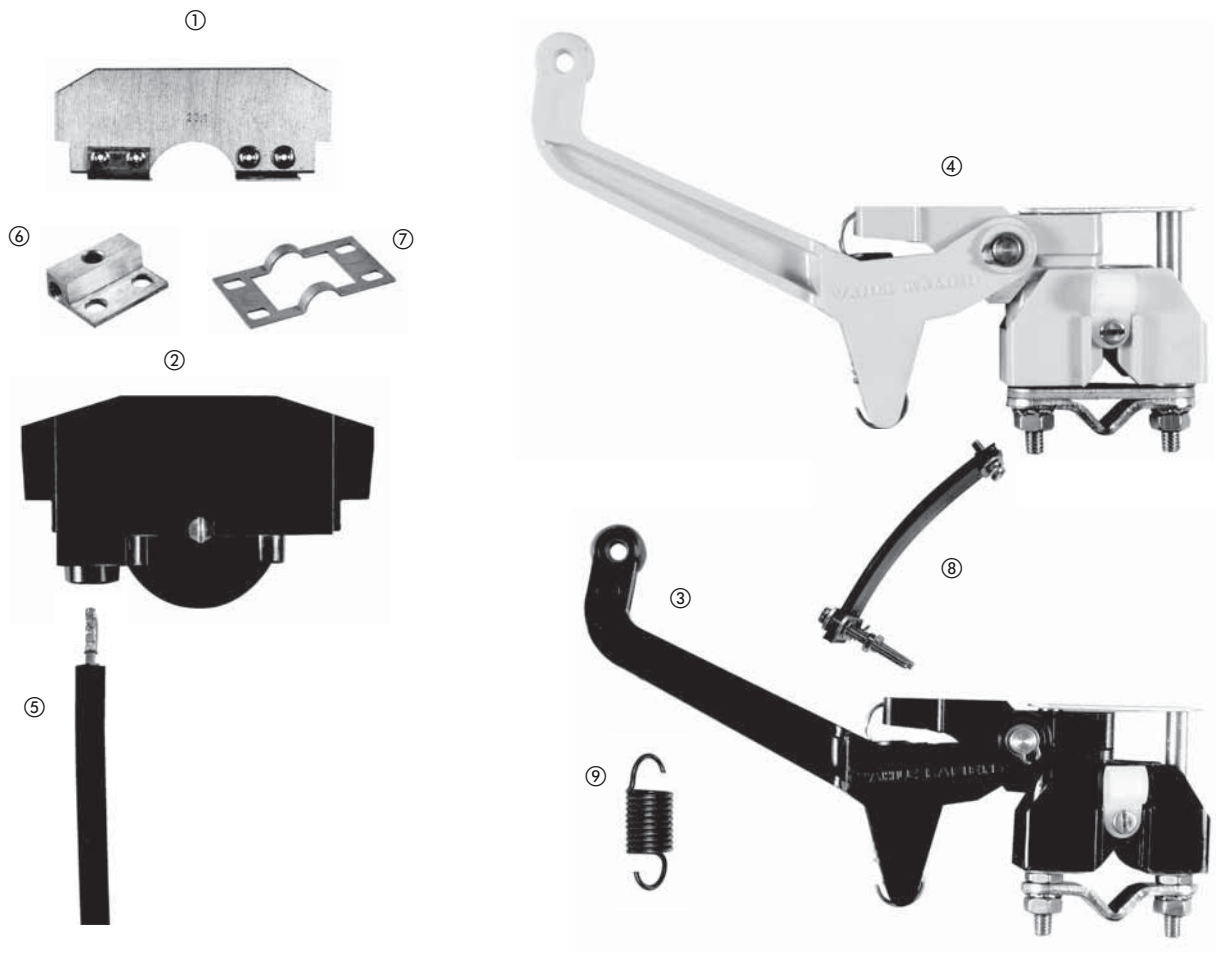



COLLECTOR COMPONENTS FOR U 20

Collectors of type KSTL 35 V. and KDSTL 70 V.

Part-No.	Description		Weight kg	Order- No.
1	Brush KMK 35 VB	phase	0,030	121 063
2	Brush KMK 35 V	ground	0,030	121 062
3	Collector base with brush holder for KSTL 35 VB	phase	0,110	121 203
4	Collector base with brush holder for KSTL 35 V	ground	0,110	121 204
5	Collector base with brush holder for KDSTL 70 VB	phase	0,174	121 207
6	Collector base with brush holder for KDSTL 70 V	ground	0,172	121 208
7	Connecting cable RKA 6/5	phase	0,256	127 437
7	Connecting cable RKA 6/5	ground	0,256	127 438
8	Tension spring ZF 4 H		0,004	170 601

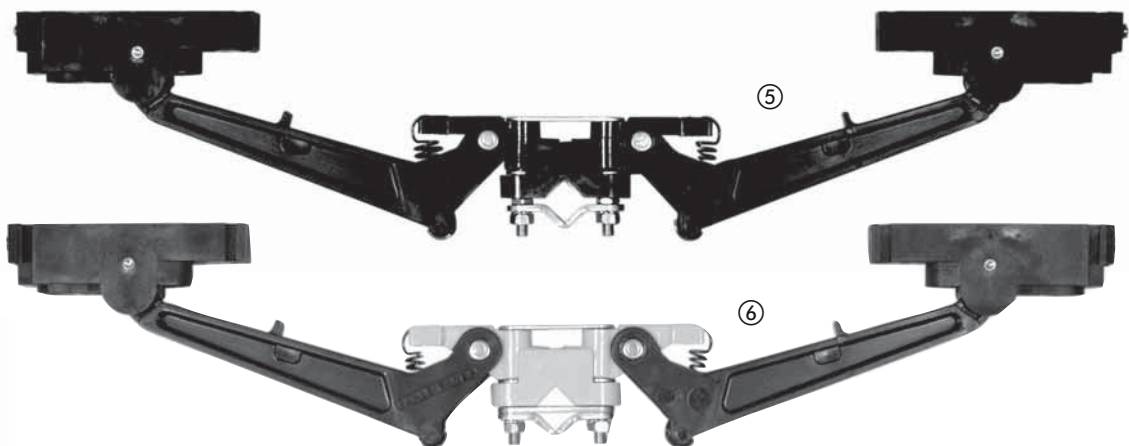
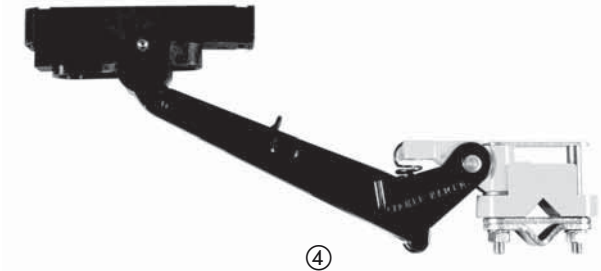
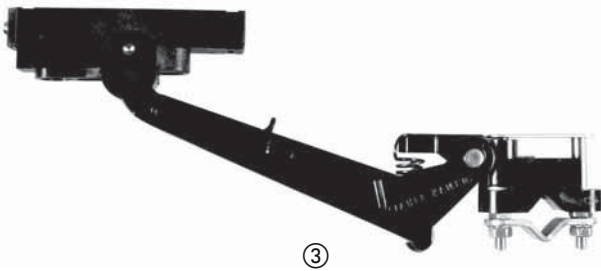
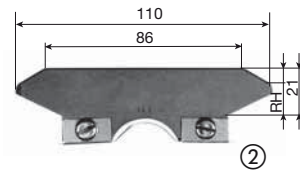
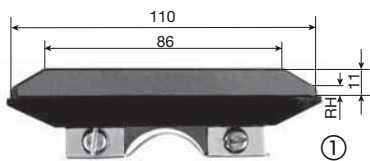

Compact configuration, 31 m power supply system, 4 pole + ground, 120 A

	Qty.	Description	Type	Order- No.	
	20	Insulated conductors, 6 m long	phase	U 20/50 AC	127 026
	4	Insulated conductors, 1 m long	phase	U 20/50 AC	127 021
	5	Insulated conductors, 6 m long	ground	U 20/50 AC	127 126
	1	Insulated conductor, 1 m long	ground	U 20/50 AC	127 121
	25	Rigid joints		UV 20/50	120 180
	5	Feed terminals		UE 20/50 K 4	126 522
	10	Locating clamps		USK 20 K 4	120 140
	10	End caps		UK 20	120 120
	32	Compact hangers, 5 pole		KH 20/5-5	126 616
	32	Bracket profiles, 230 mm long		HU 20/230	120 833
	4	Current collectors	phase	KST 40	152 840
	1	Current collectors	ground	KST 40	152 850
	1	Collector bracket		UM 12	153 5061
	1	Contact paste			121 502

Standard configuration, 60 m power supply system, 3 pole + ground, 200 A

	Qty.	Description	Type	Order- No.	
<p>Dimensions in parenthesis include insulators GH 40 with rail holder UAK 20</p>	30	Insulated conductors, 6 m long	phase	U 20/50 C	127 036
	10	Insulated conductors, 6 m long	ground	U 20/50 C	127 136
	36	Rigid joints		UV 20/50	120 180
	4	Feed terminals		UE 20/50 K 4	126 522
	8	Locating clamps		USK 20 K 4	120 140
	8	End caps		UK 20	120 120
	244	Insulated hangers		UAM 20	126 540
	3	Current collectors	phase	UDST 120	120 967
	1	Current collectors	ground	UDST 120	120 968
	1	Collector bracket		UM 16	126 574
	1	Contact Paste			121 502



INSULATED CONDUCTORS U 30

Type	U 30/120 CE	U 30/75 C	U 30/100 C	
Weight kg/m	1,440	1,100	1,360	
Standard shrouding, color green				
Order- No. phase ⁽³⁾	130 24 •	130 28 •	130 32 •	
Order- No. ground ⁽³⁾	130 25 •	130 29 •	130 33 •	
High temperature shrouding, color grey				
Order- No. phase ⁽³⁾	130 26 •	130 30 •	130 34 •	
Order- No. ground ⁽³⁾	130 27 •	130 31 •	130 35 •	

Type	U 30/130 CH	U 30/150 C	U 30/200 C	U 30/200 CH
Weight kg/m	1,540	1,780	2,180	2,180
Standard shrouding, color green				
Order- No. phase ⁽³⁾	130 36 •	130 40 •	130 44 •	130 48 •
Order- No. ground ⁽³⁾	130 37 •	130 41 •	130 45 •	130 49 •
High temperature shrouding, color grey				
Order- No. phase ⁽³⁾	130 38 •	130 42 •	130 46 •	130 50 •
Order- No. ground ⁽³⁾	130 39 •	130 43 •	130 47 •	130 51 •

Engineering data

Type	Conductor cross section mm ²			Leakage distance of shroud mm	max. voltage V	max. continuous ampere capacity A at 35° C	Resistance Ohm/1000 m	Impedance ⁽¹⁾ Ohm/1000 m
	Cu	Al	Stahl					
U 30/120 CE	100		18	100	1000	330	0,178	0,222
U 30/ 75 C	75			100	1000	280	0,238	0,280
U 30/100 C	100			105	1000	330	0,178	0,264
U 30/130 CH	130			95	1000	400	0,137	0,221
U 30/150 C	150			95	1000	440	0,126	0,219
U 30/200 C	200			90	1000	530	0,090	0,195
U 30/200 CH	200			90	1000	530	0,090	0,195

Conductor Code:

U = Insulated Conductors
 30 = Shroud Size
 75-225 = Conductor Cross Sectional Area (mm²)
 CE = Copper/stainless steel conductor
 C = Copper conductor
 CH = Copper conductor with extra deep groove for high speed applications

Application:

for indoor and outdoor

Supply length:

6 m standard
 Shorter lengths are available.

Bending:

factory fabricated on request

Support spacing:

– for straight runs and lateral curves: 1500 mm
 – for horizontal curves RH < 10 m⁽²⁾: 750 mm
 – for horizontal curves RH > 10 m: 1500 mm

Heating system:

The conductor Type U 30/75 C can be equipped with heating cable for icing conditions.

See page 4 for chemical and electrical properties

⁽¹⁾ With 80 mm phase distance and 50 Hz

⁽²⁾ Recommended

⁽³⁾ Add last number (1, 2, 3, 4, 5 or 6 m length suffix) in accordance to bars required. Short length have to be rounded up.



Rigid joints

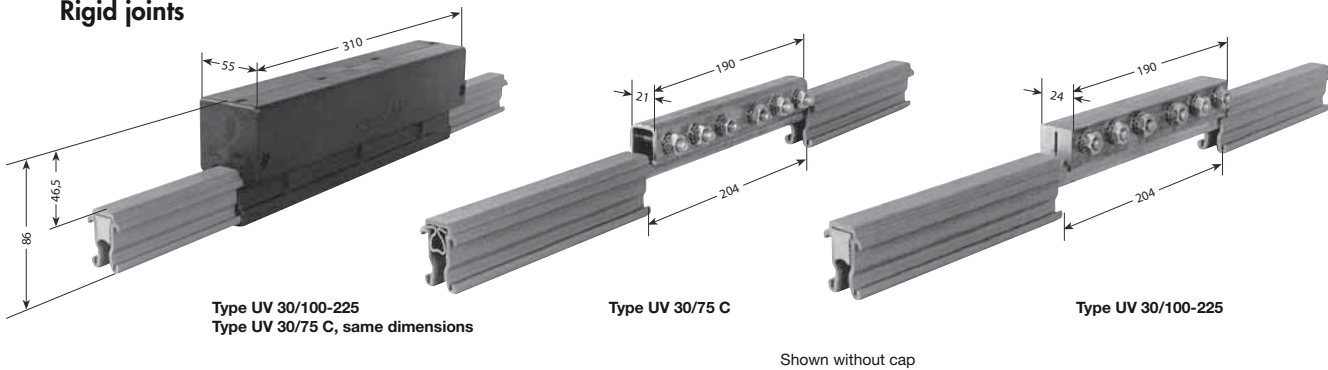

Type	for conductor type	Weight kg	Order- No.
UV 30/75 C	U 30/75 C	0,780	130 525
UV 30/75 C K 4⁽¹⁾	U 30/75 C	0,780	130 526
UV 30/100-225	U 30/120 CE, U 30/100 C,	1,180	130 527
UV 30/100-225 K 4⁽¹⁾	U 30/130 CH, U 30/150 C, U 30/200 C, U 30/200 CH,	1,180	130 528

Expansion sections

consisting of expansion joint with rigid joint installed on a conductor rail of 1.5 m length. They are used in systems >100 m. The 1.5 m expansion assembly is part of the system length and has to be considered. Expansion sections with 70 mm expansion are available.

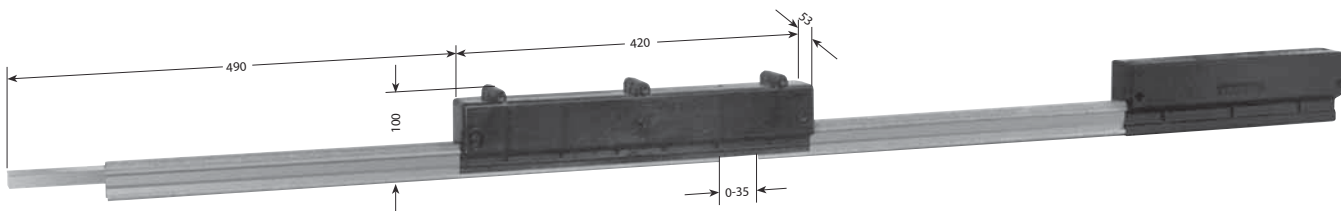

Investigation of expansion sections

$n = \frac{L_1}{L}$
 n = Number of UDV (rounded)
 L₁ = Length of assembly minus 100 m
 L = Expansion capacity max. of UDV (see table)

to Δ t	max. L / U 30	to Δ t	max. L / U 30
20 °C	100 m	40 °C	50 m
30 °C	168 m	50 °C	40 m

Standard shrouding, color green

Type	Weight kg	Order- No.	
		phase	ground
UDV 30/120 CE	4,980	130 533	130 534
UDV 30/ 75 C	4,470	130 535	130 536
UDV 30/100 C	4,860	130 537	130 538
UDV 30/130 CH	5,130	130 539	130 540
UDV 30/150 C	5,490	130 541	130 542
UDV 30/200 C	6,090	130 543	130 544
UDV 30/200 CH	6,090	130 545	130 546
UDV 30/120 CE K 4⁽¹⁾	4,980	130 551	130 552
UDV 30/ 75 C K 4⁽¹⁾	4,470	130 553	130 554
UDV 30/100 C K 4⁽¹⁾	4,860	130 555	130 556
UDV 30/130 CH K 4⁽¹⁾	5,130	130 557	130 558
UDV 30/150 C K 4⁽¹⁾	5,490	130 559	130 560
UDV 30/200 C K 4⁽¹⁾	6,090	130 561	130 562
UDV 30/200 CH K 4⁽¹⁾	6,090	130 563	130 564

High temperature shrouding, color grey

Type	Weight kg	Order- No.	
		phase	ground
UDV 30/120 CE	4,980	130 569	130 570
UDV 30/ 75 C	4,470	130 571	130 572
UDV 30/100 C	4,860	130 573	130 574
UDV 30/130 CH	5,130	130 575	130 576
UDV 30/150 C	5,490	130 577	130 578
UDV 30/200 C	6,090	130 579	130 580
UDV 30/200 CH	6,090	130 581	130 582
UDV 30/120 CE K 4⁽¹⁾	4,980	130 587	130 588
UDV 30/ 75 C K 4⁽¹⁾	4,470	130 589	130 590
UDV 30/100 C K 4⁽¹⁾	4,860	130 591	130 592
UDV 30/130 CH K 4⁽¹⁾	5,130	130 593	130 594
UDV 30/150 C K 4⁽¹⁾	5,490	130 595	130 596
UDV 30/200 C K 4⁽¹⁾	6,090	130 597	130 598
UDV 30/200 CH K 4⁽¹⁾	6,090	130 599	130 600

⁽¹⁾ Stainless steel hardware



FEED TERMINALS FOR U 30

Feed terminals

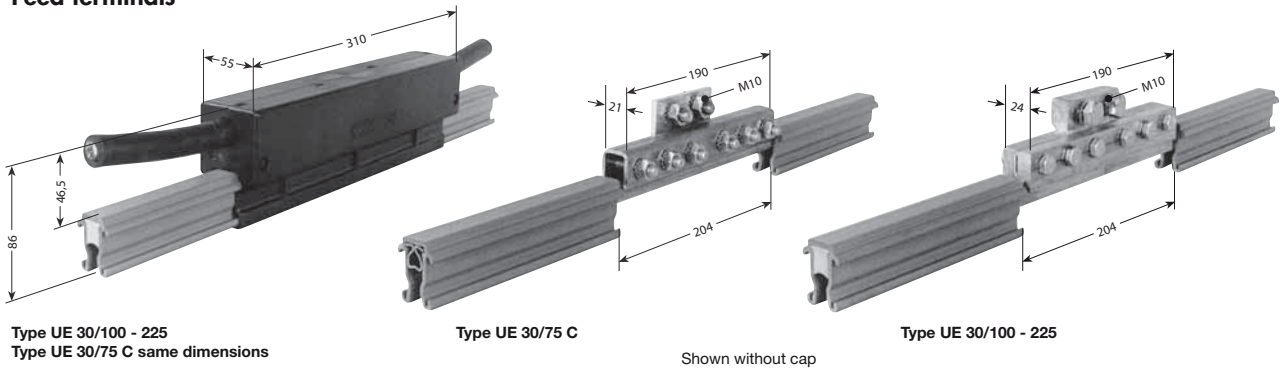

Type	Connecting cable max. mm ²	Weight kg	Order- No.
UE 30/75 C	2 x 70	0,990	130 601
UE 30/75 CK 4 ⁽¹⁾	2 x 70	0,990	130 602
UE 30/100 -225	2 x 70	1,480	130 603
UE 30/100-225 K 4 ⁽¹⁾	2 x 70	1,480	130 604

Feed terminals

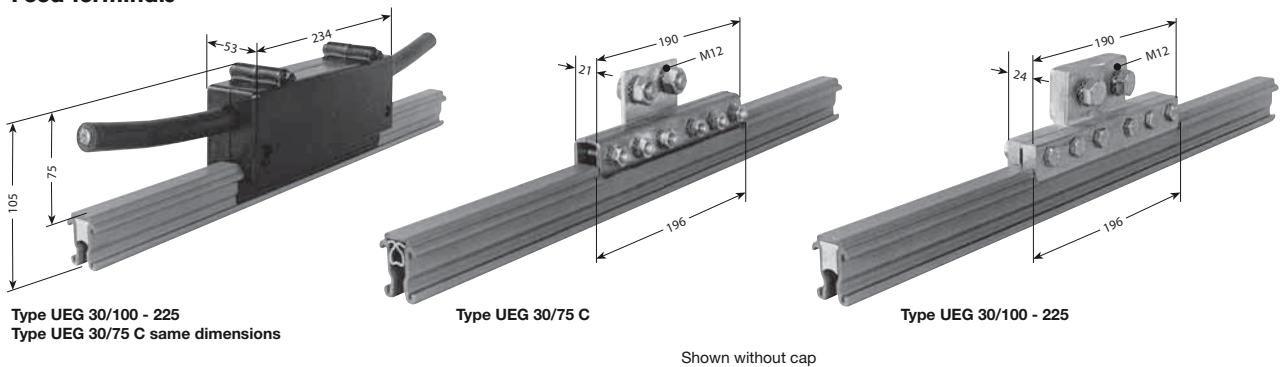

For mid-rail assembly only.

Type	Connecting max. mm ²	Weight kg	Order- No.
UEG 30/75 C	2 x 95	0,940	130 605
UEG 30/75 CK 4 ⁽¹⁾	2 x 95	0,940	130 606
UEG 30/100-225	2 x 120	1,615	130 607
UEG 30/100-225 K 4 ⁽¹⁾	2 x 120	1,615	130 608

Contact paste for joints and feeds

20 g for ca. 40 joints	Order- No. 120 016
500 g for ca. 1000 joints	Order- No. 120 017

Locating clamp

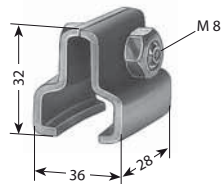

Type	Weight kg	Order- No.
USK 30 K 4 ⁽¹⁾	0,065	133 537

End caps

incl. Locking pin



Type	Weight kg	Order- No.
UK 30-L	0,025	132 120
UK 30-M	0,025	130 158



Transfer guides

Transfer guides are used for transfer or power interrupting applications.
 Max. vertical and horizontal offset: ± 4 mm, max. air gap: 10 mm.
 Additional hangers are required and have to be ordered separately.

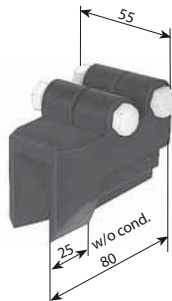

Type	Weight kg	Order- No.
US 30/120 CE	0,090	133 587
US 30/ 75 C	0,090	133 250
US 30/100 C	0,090	133 260
US 30/130 CH	0,090	133 280
US 30/150 C	0,090	133 290
US 30/200 C	0,090	133 300
US 30/200 CH	0,090	133 791

Transfer guides US 30 are fastened to conductor ends by means of two screws.

Isolating sections

Type M: Factory assembled per system layout
 Type L: Loose, including two locking pins 4 x 18

Position of isolating sections per system layout. Use one extra hanger each side, max. 300 mm away for stability.
 Rails, hangers & feed terminal to be ordered separately.

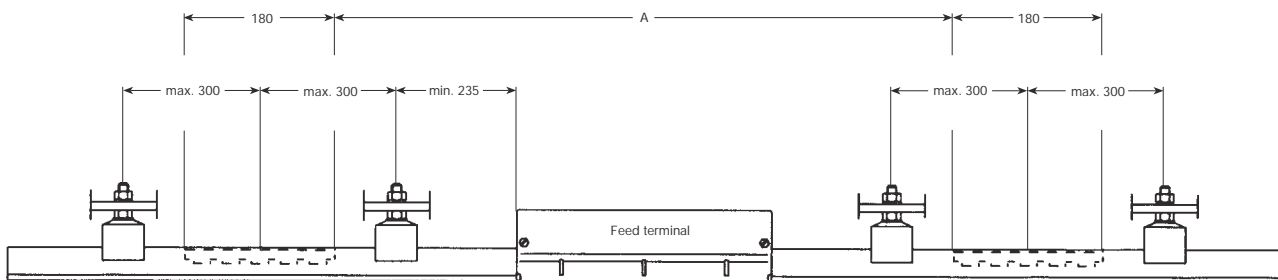
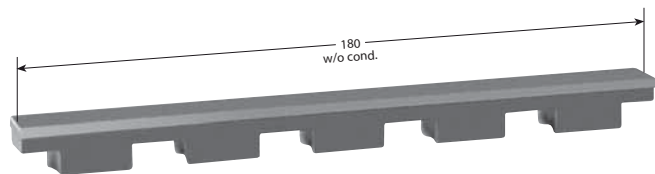

To avoid voltage by-pass by carbon brushes and to separate maintenance bays, control and main feed sections, double isolating sections are recommended.

Dim. A depends on type and number of current collectors and stopping distance of the crane.

Type	Weight kg	Order- No.
IT/U 30/120 CE-M	0,021	133 588
IT/U 30/ 75 C -M	0,021	133 070
IT/U 30/100 C -M	0,021	133 080
IT/U 30/130 CH-M	0,021	133 100
IT/U 30/150 C -M	0,021	133 110
IT/U 30/200 C -M	0,021	133 120
IT/U 30/200 CH-M	0,021	133 792

Type	Weight kg	Order- No.
IT/U 30/120 CE-L	0,021	132 580
IT/U 30/ 75 C -L	0,021	132 560
IT/U 30/100 C -L	0,021	132 570
IT/U 30/130 CH-L	0,021	132 600
IT/U 30/150 C -L	0,021	132 610
IT/U 30/200 C -L	0,021	132 620
IT/U 30/200 CH-L	0,021	132 640



HANGERS FOR U 30

Insulated hangers⁽²⁾

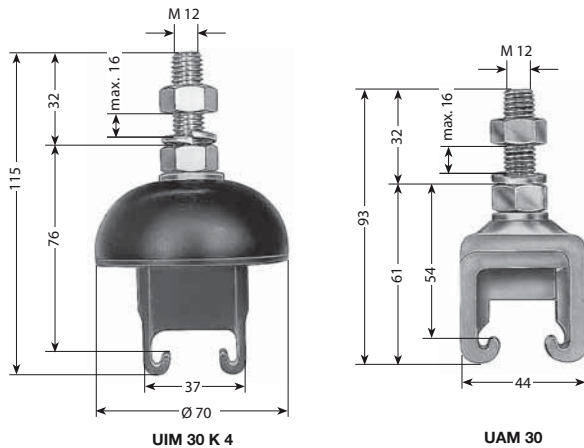

Type	Weight kg	Order- No.
UIM 30 K 4⁽¹⁾	0,160	133 768
UAM 30	0,160	132 690
UAM 30 K 4⁽¹⁾	0,160	132 700

Hangers⁽²⁾

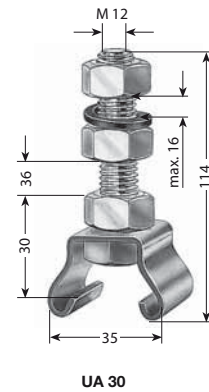

Type	Weight kg	Order- No.
UA 30	0,193	132 150
UA 30 K 4⁽¹⁾	0,193	132 510

Insulators⁽²⁾

High voltage insulators are available

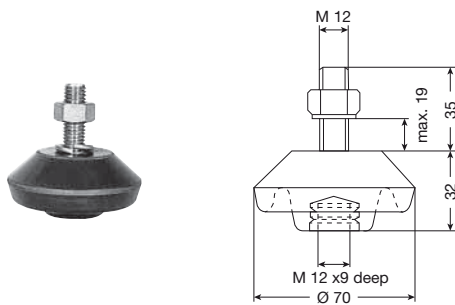

Type	Weight kg	Order- No.
GHH 30 - M 12	0,245	130 000
GHH 30 - M 12 K 4⁽¹⁾	0,245	130 002

Cantilever strength = 4500 N
Leakage distance = 70 mm

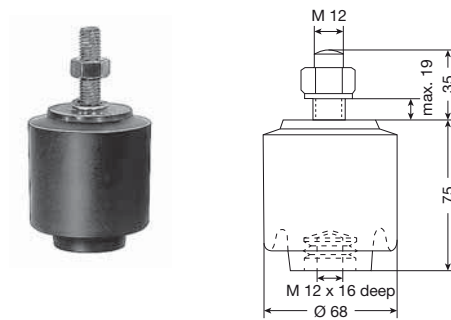

Type	Weight kg	Order- No.
GHH 75 - M 12	0,560	133 564
GHH 75 - M 12 K 4⁽¹⁾	0,560	133 566

Cantilever strength = 6500 N
Leakage distance = 115 mm

Rail holders

to go with insulators

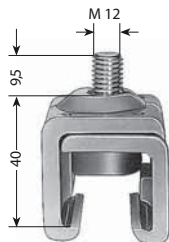

Type	Weight kg	Order- No.
UAK 30 K 4⁽¹⁾	0,100	133 568

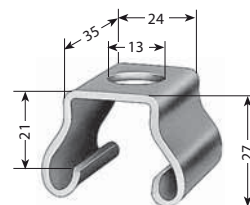

Supplied with bolt M 12 x 12

Type	Weight kg	Order- No.
UAS 30 K 4⁽¹⁾	0,080	132 710

⁽¹⁾ Stainless steel hardware

⁽²⁾ For installation in slotted holes use on both sided discs according to DIN 9021.



Any number of conductors can be assembled by cutting/combining the compact hangers.
The joints have to be arranged staggered.

Compact hanger, 4 pole for direct bolting

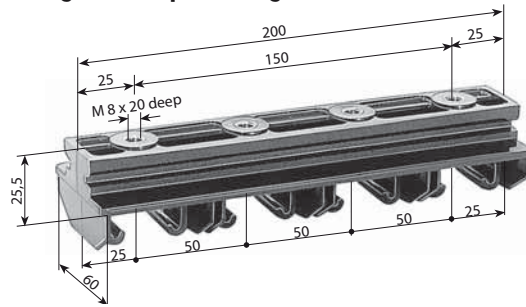

Type	Weight kg	Order- No.
KA 30/4	0,172	133 570

Compact hanger, 4 pole to go with bracket 38/17

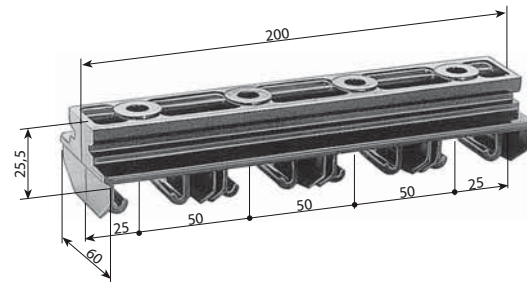

Type	Weight kg	Order- No.
KH 30/4	0,165	133 571

Attachment hardware for compact hangers, insulated hangers and insulators

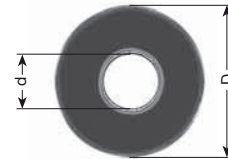
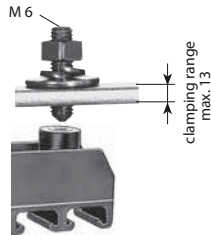

Type	Weight kg	Order- No.
BE 8	0,028	130 060
BE 8 K 4⁽¹⁾	0,028	130 111

Type	Threat	d mm	D mm	S mm	Weight kg	Order- No.
Washer 8,4	M 8	8,4	25	2	0,007	130112
Washer 8,4 K 4⁽¹⁾	M 8	8,4	25	2	0,007	130110

Bracket profiles 38/17

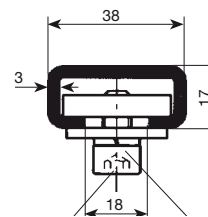

Type	Lenght mm	Number of poles	Weight kg	Bestell-Nr.
HU 30/400	400	5	0,820	130 113
HU 30/600	600	10	1,160	130 114

Transfer funnel for compact arrangement EMK 30/1-6.

Transfer funnels are for spurlines, switches and turntables required.

The have a height and lateral tolerance of +/- 25 mm.
The conductor distance has to be 50 mm.

Collector types KSTU 140 and KDSTU 280 have to be used.

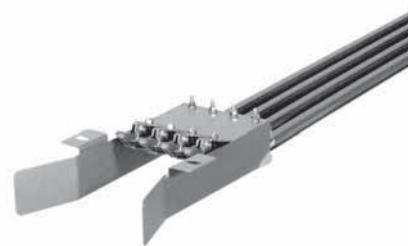

For construction please request drawing.

⁽¹⁾ Stainless steel hardware



CURRENT COLLECTORS FOR U 30

Current collectors

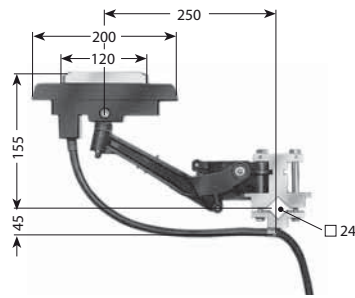

with 2 m Connecting cable
 lift + 45/ -40 mm
 swivel ± 60 mm
 contact pressure: approx. 30 N

Double collector

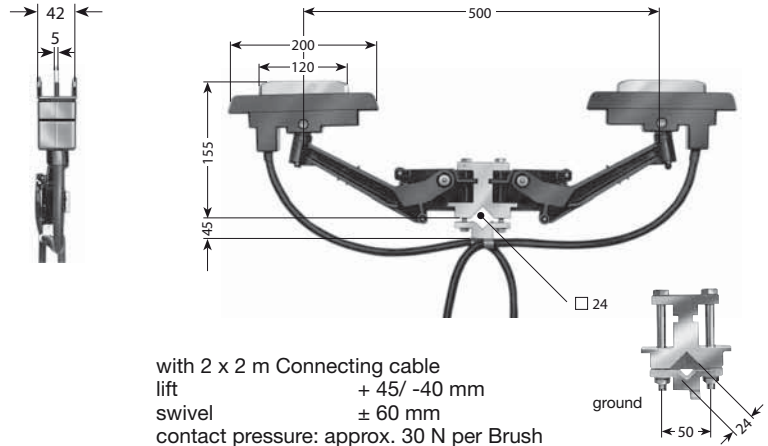

with 2 x 2 m Connecting cable
 lift + 45/ -40 mm
 swivel ± 60 mm
 contact pressure: approx. 30 N per Brush

Type	Am- pacity A	Connecting cable		Weight kg	Order- No.		Type	Am- pacity A	Connecting cable		Weight kg	Order- No.	
		mm ²	ø max/ mm		phase black	ground yellow			mm ²	ø max/ mm		phase black	ground yellow
KST 100/30	100	16	14,5	1,724	133 938	133 939	KDST 200/30	200	16	14,5	3,111	133 940	133 941
KST 125/30	125	25	16,5	1,960	130 863	130 864	KDST 250/30	250	25	16,5	3,583	130 865	130 866

Current collectors⁽¹⁾

for transfer applications **KSTU 140/30**

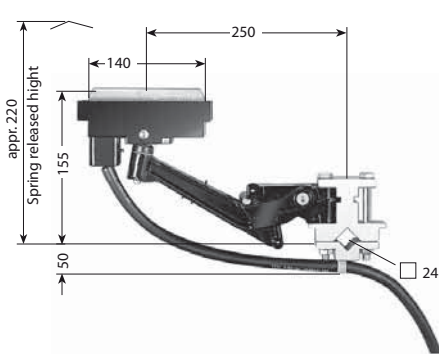

with 2 m connecting cable
 lift + 45/ -40 mm
 swivel ± 60 mm
 contact pressure: approx. 29 N

Double collectors⁽¹⁾

for transfer applications **KDSTU 280/30**

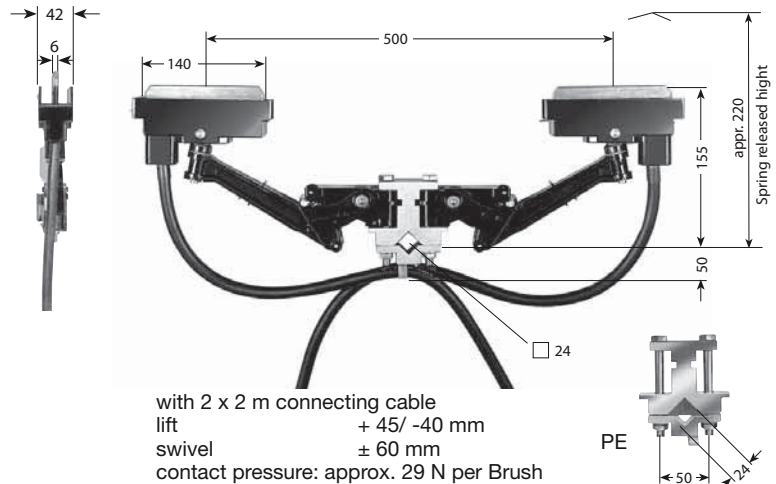

with 2 x 2 m connecting cable
 lift + 45/ -40 mm
 swivel ± 60 mm
 contact pressure: approx. 29 N per Brush

Type	Am- pacity A	Connecting cable		Weight kg	Order- No.		Type	Am- pacity A	Connecting cable		Weight kg	Order- No.	
		mm ²	ø max/ mm		phase black	ground yellow			mm ²	ø max/ mm		phase black	ground yellow
KSTU 140/30	140	25	16,5	1,935	130 048	130 049	KDST 280/30	280	25	16,5	3,395	130 052	130 053
KST 140/30	140	25	16,5	1,990	130 050	130 051	KDSTU 280/30	280	25	16,5	3,535	130 054	130 055
KST 175/30	175	35	18,5	2,183	130 869	130 870	KDST 350/30	350	35	18,5	3,891	130 873	130 874
KSTU 175/30	175	35	18,5	2,238	130 871	130 872	KDSTU 350/30	350	35	18,5	4,031	130 875	130 876

Collector bracket

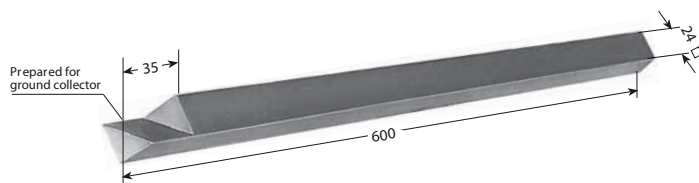

Type	Weight kg	Order- No.
UM 24	2,600	175 076

With a length above 600 mm for the towing arm a support have to be considered on site to prevent bending or twisting.

Longer length are available.

⁽¹⁾ Special version for acid factories available.
 Ampacity with use on stainless steel conductors on request.

COLLECTOR COMPONENTS U 30 - EXAMPLE FOR ORDERING



Copper-graphite brush

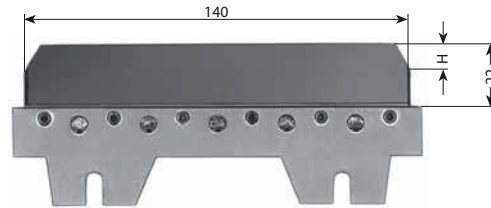

Dim. H: max. wear for U 30/100 C

KMK 100/30

KMK 140/30

Type	for collector	H mm	Weight kg	Order- No.
KMK 100/30	KST 100/30, KDST 200/30	4	0,198	130 609
KMK 140/30	KST 140/30, KDST 280/30, KSTU 140/30, KDSTU 280/30	5,5	0,177	133 590

Tension spring

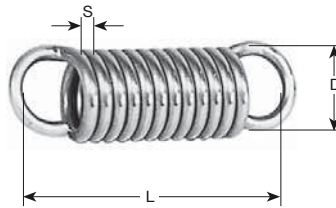

Type	for collector	Weight kg	L mm	D mm	S mm	Order- No.
ZF 6	KST 100/30, KST 140/30, KDST 200/30 KST 140/30, KDST 280/30, KSTU 140/30, KDSTU 280/30	0,023	56,50	17,30	2,25	170 167

Example for ordering 160 m power supply system, 3 pole + ground, 530 A

	Qty.	Description	Type	Order- No.
	78	Insulated conductors, 6 m long	phase	U 30/200 C 130 446
	3	Insulated conductors, 1 m long	phase	U 30/200 C 130 441
	26	Insulated conductors, 6 m long	ground	U 30/100 C⁽¹⁾ 130 336
	1	Insulated conductor, 1 m long	ground	U 30/100 C⁽¹⁾ 130 331
	6	Expansion sections, 1,5 m long	phase	UDV 30/200 C 130 543
	2	Expansion sections, 1,5 m long	ground	UDV 30/100 C⁽¹⁾ 130 538
	104	Rigid joints		UV 30/100-225 130 527
	8	Feed terminals		UE 30/100-225 130 603
	24	Locating clamps		USK 30 K 4 133 537
	8	End caps		UK 30 132 120
	432	Insulated hangers		UAM 30 132 690
	6	Double collectors, phase		KDST 280/30 130 052
	1 ⁽¹⁾	Double collectors, ground		KDST 280/30 130 053
	2	Collector bracket		UM 24 175 076

Dimensions in parenthesis include insulators GHH 75/UAS 30 with railholder UAK 30 K 4

⁽¹⁾ Capacity reduces per VDE 0100, part 540



COLLECTOR COMPONENTS U 30

Spare parts for collectors of type KST 100/30 upto KDST 200/30

Part.-No.	Description	Weight kg	Order- No.
1	Brush (see page 28)	–	–
2	Brush holder for KST 100	0,195	170 338
3	Collector base for KST 100	0,662	170 340
4	Collector base for KDST 200	0,731	170 341
5	Collector base for KDST 200	0,887	170 342
6	Collector base for KDST 200	0,953	170 343
7	Connecting cable RKA 16/8 PH, 2 m long	0,614	170 344
8	Connecting cable RKA 16/8 PE, 2 m long	0,459	170 345
9	Terminal bolt M8 x 20 K4	0,022	170 818
9	Tension spring (see page 27)	–	–

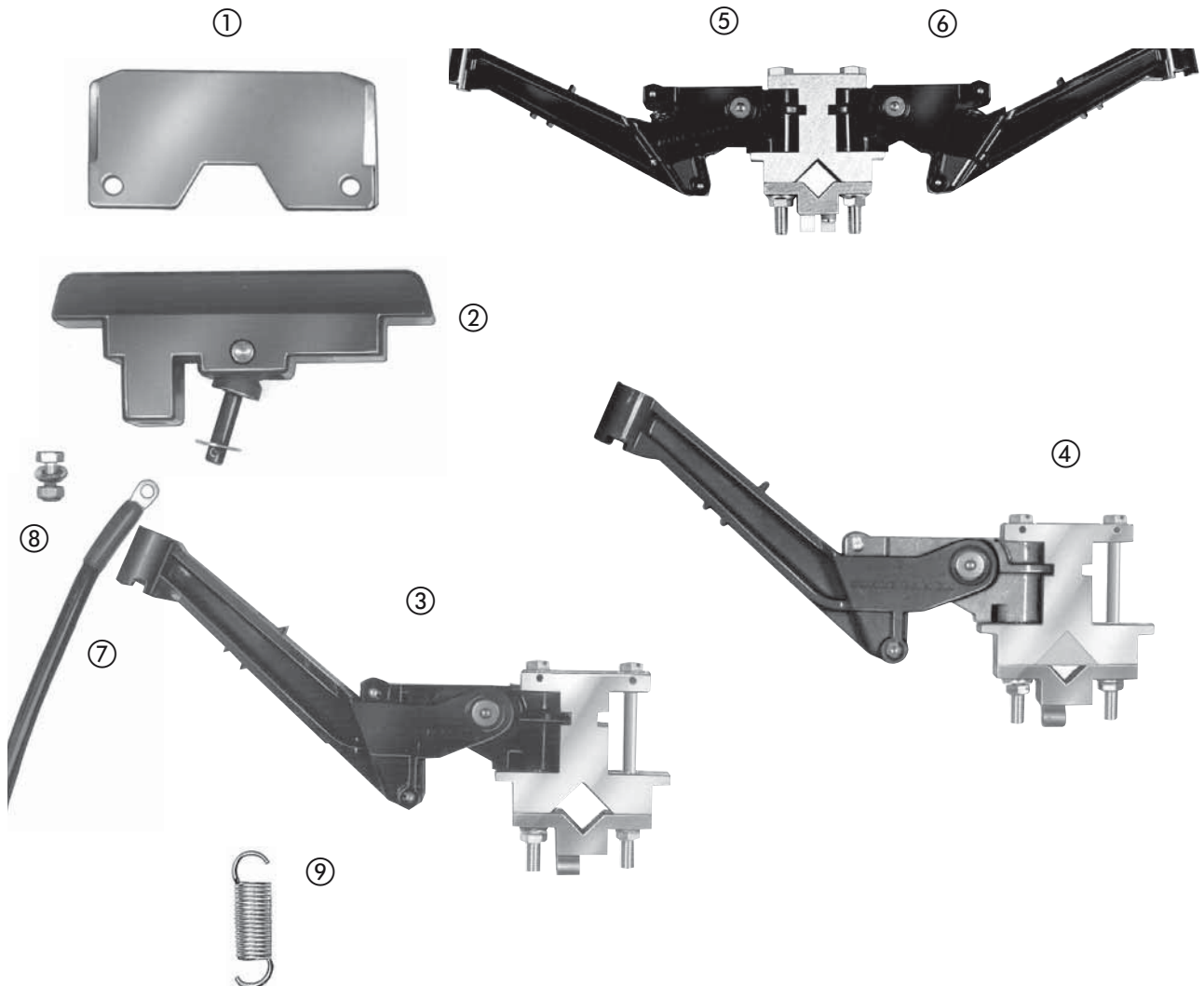



Spare parts for collectors of type KST 140/30 upto KDSTU 280/30

Order- No.				
1	Brush (see page 27)		-	-
2	Brush holder with carbon holder for KST 140	phase ground	0,375	170 169 170 169
3	Collector base for KST 140	phase	0,662	170 795
4		ground	0,731	170 796
3	Collector base for KSTU 140	phase	0,555	170 555
4		ground		170 556
5	Collector base for KDST 280	phase	0,887	170 791
6		ground	0,953	170 792
5	Collector base for KDSTU 280	phase	0,795	170 557
6		ground		170 558
7	Connecting cable RKA 25/8 PH, 2 m long	phase	0,840	170 173
	Connecting cable RKA 25/8 PE, 2 m long	ground	0,600	170 174
8	Terminal bolt M 8 x 12 K 4		0,010	170 871
9	Rubber spring complete for KSTU 140, KDSTU 280		0,035	170 412
10	Tension spring (see page 27)		-	-

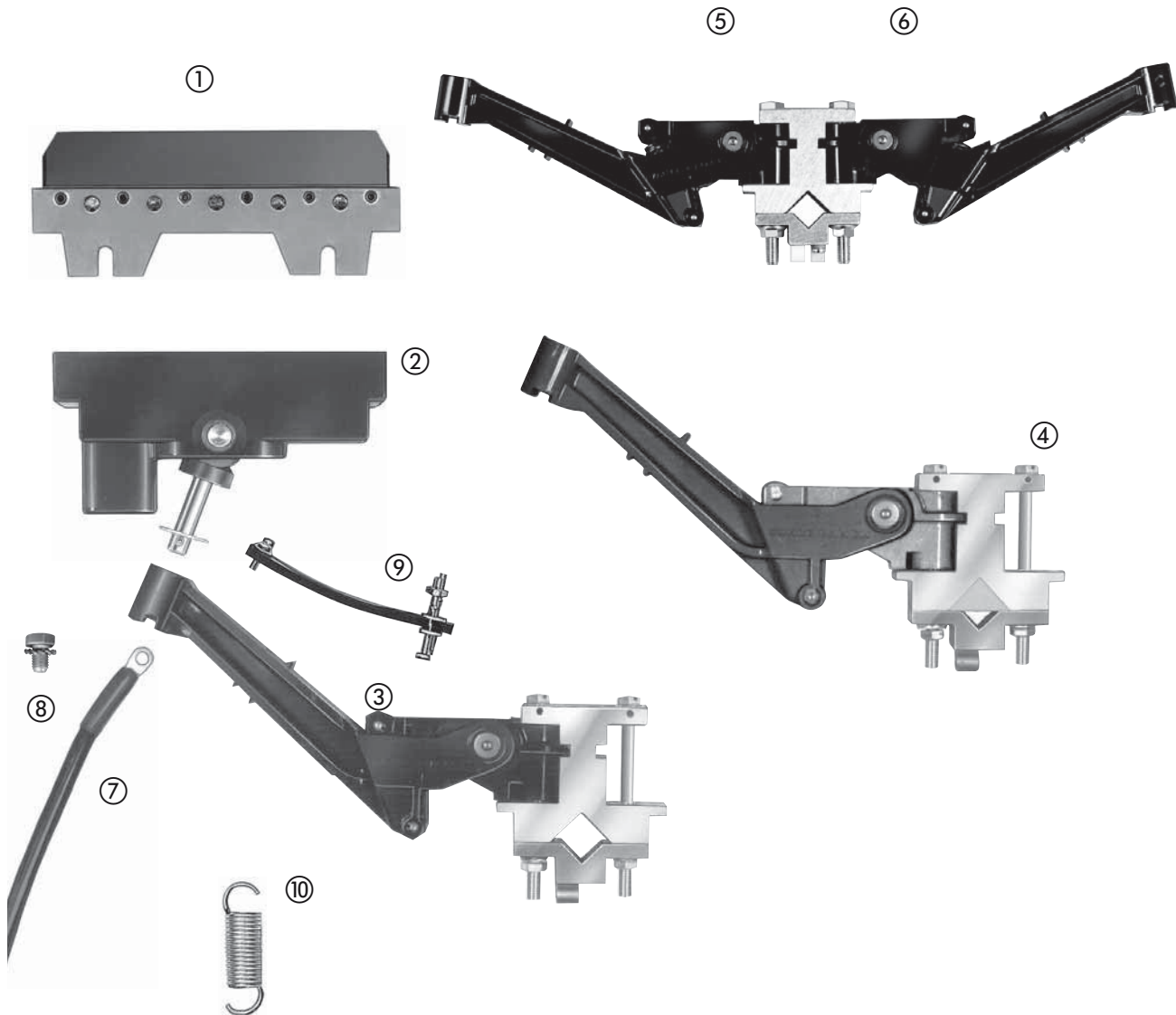



INSULATED CONDUCTORS U 40

Type	U 40/200 C	U 40/300 C
Weight kg/m	2,550	3,460
Standard shrouding, color green		
Order- No. ⁽¹⁾ phase	136 01 •	134 34 •
Order- No. ⁽¹⁾ ground	136 15 •	136 16 •
High temperature shrouding, color grey		
Order- No. ⁽¹⁾ phase	136 06 •	136 07 •
Order- No. * ground	136 24 •	136 25 •

Type	U 40/400 CH	U 40/500 C
Weight kg/m	4,360	5,240
Standard shrouding, color green		
Order- No. ⁽¹⁾ phase	136 04 •	134 36 •
Order- No. ⁽¹⁾ ground	136 20 •	136 21 •
High temperature shrouding, color grey		
Order- No. ⁽¹⁾ phase	136 11 •	136 12 •
Order- No. ⁽¹⁾ ground	136 29 •	136 30 •

Conductor code::

U = Unipole insulated conductor
 40 = Shroud size
 200-500 = Conductor cross sectional area (mm²)
 C = Copper conductor
 CH = Copper conductor with extra deep groove for high speed
 CHH = See CH plus for heating

Application:

indoors and outdoors

Supply lengths:

6 m standard
 shorter lengths are available.

Support spacing:

2000 mm

Heating system:

The conductors type U 40/200 C, U 40/300 CH and U 40/500 CHH can be equipped with heating cable for icing conditions.

Factory-fabricated radius bends to your drawings or sketches are available.

See page 4 for electrical and mechanical properties.

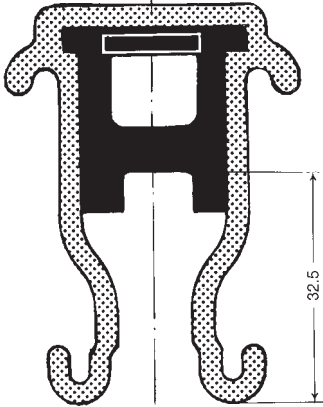
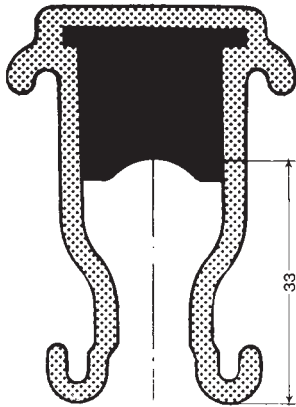

		
	U 40/300 CH	U 40/400 C
	3,500	4,380
	136 02 •	134 35 •
	136 17 •	136 19 •
	136 08 •	136 10 •
	136 26 •	136 28 •

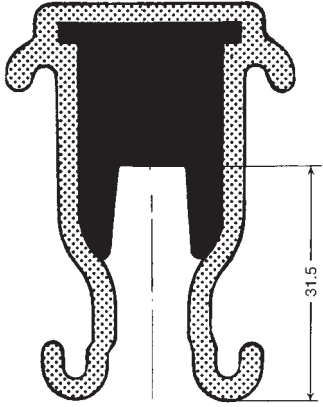
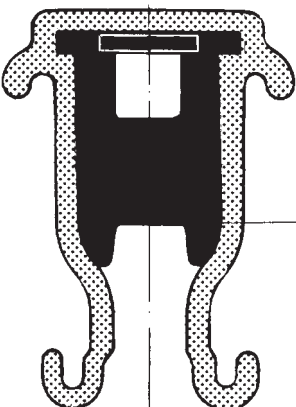
		
	U 40/500 CH	U 40/500 CHH
	5,250	5,000
	134 15 •	136 05 •
	136 22 •	136 23 •
	136 13 •	136 14 •
	136 31 •	136 32 •

Engineering data

Conductor Type	Conductors cross sectionmm ²		Leakage distance of shroud mm	max. voltage V	max. continuous ampere capacity A at 35 °C	Resistance (R) Ohm/1000 m	Impedance ⁽²⁾ Ohm/1000 m
	Copper	Al					
U 40/200 C	200		130	1000	600	0,089	0,170
U 40/300 C	300		135	1000	700	0,063	0,178
U 40/300 CH	300		130	1000	700	0,063	0,178
U 40/400 C	400		130	1000	860	0,047	0,168
U 40/400 CH	400		130	1000	860	0,047	0,168
U 40/500 C	500		125	1000	1000	0,038	0,161
U 40/500 CH	500		120	1000	1000	0,038	0,161
U 40/500 CHH	500		120	1000	1000	0,038	0,161

⁽²⁾ With 130 mm phase distance and 50 Hz



ACCESSORIES FOR U 40

Rigid joints

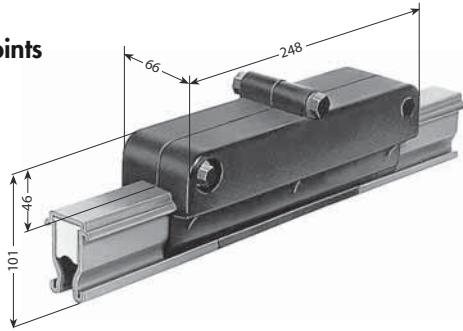

Type	Weight kg	Order- No.
UV 40/200	1,645	134 180
UV 40/200 K 4⁽¹⁾	1,645	135 140

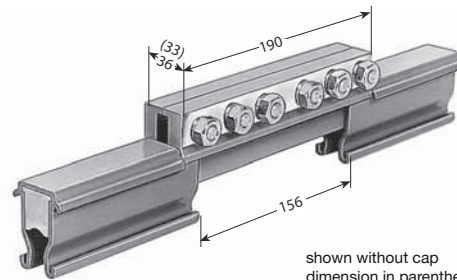

shown without cap
dimension in parenthesis for UV 40/200

Type	Weight kg	Order- No.
UV 40/300-500	1,660	135 384
UV 40/300-500 K 4⁽¹⁾	1,660	135 385

Expansion sections

consisting of expansion joint with rigid joint installed on a conductor rail of 2 m length. They are used in systems >100 m. The 2 m expansion assembly is part of the system length and has to be considered.

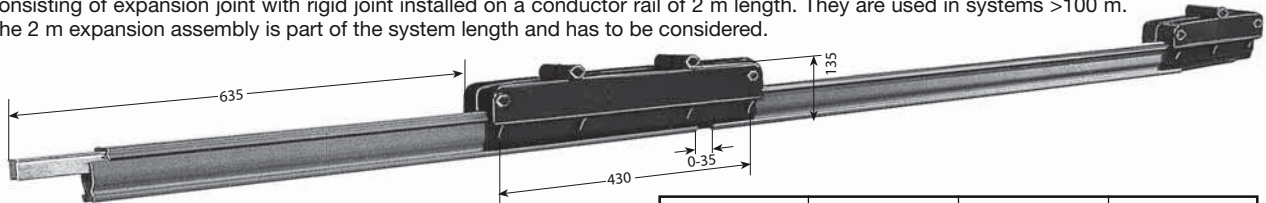

Investigation of expansion sections

$n = \frac{L_1}{L}$
 n = Number of UDV (rounded)
 L_1 = Length of assembly minus 100 m
 L = Expansion capacity max. of UDV (see table)

to Δt	max. L / U 40	to Δt	max. L / U 40
20° C	100 m	40° C	50 m
30° C	168 m	50° C	40 m

Standard shrouding, color green

Type	Weight kg	Order- No.	
		phase	ground
UDV 40/200 C	9,350	135 142	135 143
UDV 40/300 C	11,170	134 690	134 700
UDV 40/300 CH	11,250	135 144	135 145
UDV 40/400 C	13,010	134 710	134 720
UDV 40/400 CH	12,970	135 146	135 147
UDV 40/500 C	14,730	134 730	134 740
UDV 40/500 CH	14,750	134 750	134 760
UDV 40/500 CHH	14,250	135 390	135 391
UDV 40/200 C K 4⁽¹⁾	9,350	135 154	135 155
UDV 40/300 C K 4⁽¹⁾	11,170	135 156	135 157
UDV 40/300 CH K 4⁽¹⁾	11,250	135 148	135 149
UDV 40/400 C K 4⁽¹⁾	13,010	135 158	135 159
UDV 40/400 CH K 4⁽¹⁾	12,970	135 150	135 151
UDV 40/500 C K 4⁽¹⁾	14,730	135 160	135 161
UDV 40/500 CH K 4⁽¹⁾	14,750	135 162	135 163
UDV 40/500 CHH K 4⁽¹⁾	14,250	135 392	135 393

High temperature shrouding, color grey

Type	Weight kg	Order- No.	
		phase	ground
UDV 40/200 C	9,350	135 272	135 273
UDV 40/300 C	11,170	135 274	135 275
UDV 40/300 CH	11,250	135 276	135 277
UDV 40/400 C	13,010	135 280	135 281
UDV 40/400 CH	12,970	135 282	135 283
UDV 40/500 C	14,730	135 284	135 285
UDV 40/500 CH	14,750	135 286	135 287
UDV 40/500 CHH	14,250	135 370	135 371
UDV 40/200 C K 4⁽¹⁾	9,350	135 288	135 289
UDV 40/300 C K 4⁽¹⁾	11,170	135 290	135 291
UDV 40/300 CH K 4⁽¹⁾	11,250	135 292	135 293
UDV 40/400 C K 4⁽¹⁾	13,010	135 296	135 297
UDV 40/400 CH K 4⁽¹⁾	12,970	135 298	135 299
UDV 40/500 C K 4⁽¹⁾	14,730	135 300	135 301
UDV 40/500 CH K 4⁽¹⁾	14,750	135 302	135 303
UDV 40/500 CHH K 4⁽¹⁾	14,250	135 372	135 373

Contact Paste for joints and feeds

20 g for ca. 40 joints	Order- No. 120 016
500 g for ca. 1000 joints	Order- No. 120 017

Locating clamp

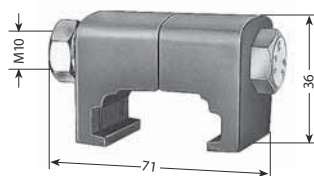

Type	Weight kg	Order- No.
USK 40 K 4⁽¹⁾	0,360	134 080

End cap

incl. locking pin



Type	Weight kg	Order- No.
UK 40-L	0,040	134 060
UK 40-M	0,040	135 974



Feed terminals

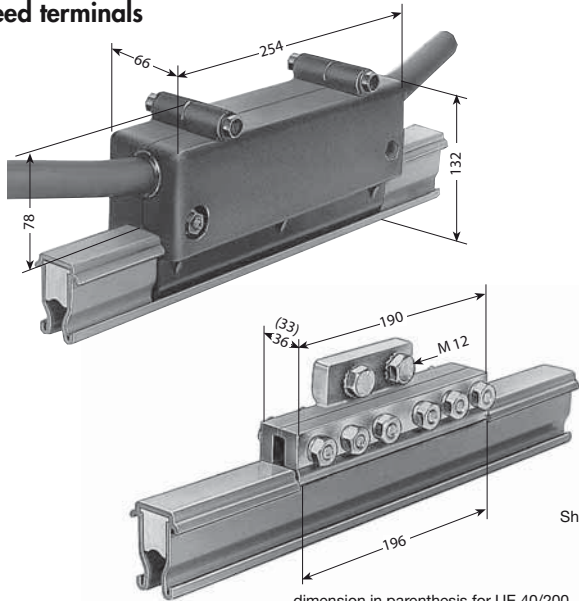

dimension in parenthesis for UE 40/200

for mid-rail assembling

Type	Weight kg	Order- No.
UE 40/200	2,120	134 280
UE 40/200 K 4⁽¹⁾	2,120	135 164
UE 40/300-500	2,130	135 386
UE 40/300-500 K 4⁽¹⁾	2,130	135 387

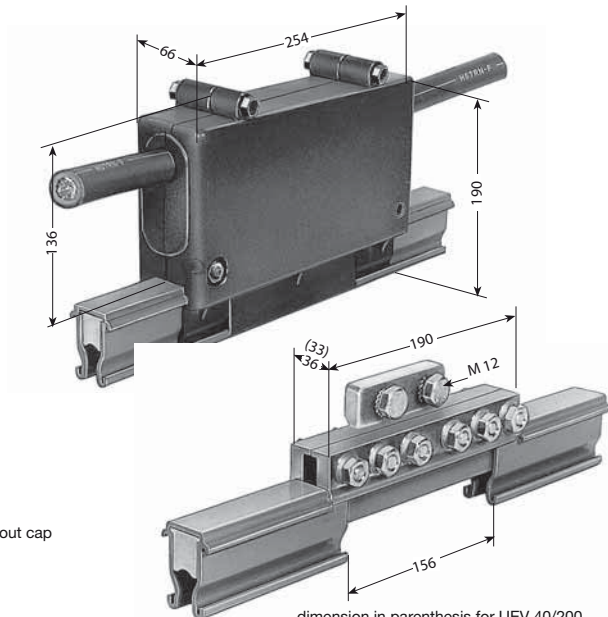

dimension in parenthesis for UEV 40/200

for joint mounting

Type	Weight kg	Order- No.
UEV 40/200	2,190	135 166
UEV 40/200 K 4⁽¹⁾	2,190	135 168
UEV 40/300-500	2,200	135 388
UEV 40/300-500 K 4⁽¹⁾	2,200	135 389

Feed cables: 2 of max. 95 mm²

Feed terminals

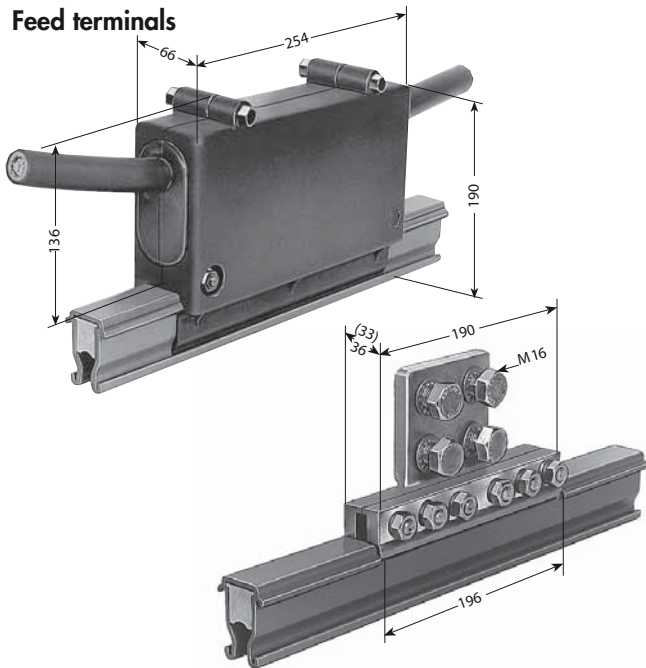

dimension in parenthesis for UEG 40/200

for mid-rail assembling

Type	Weight kg	Order- No.
UEG 40/200	2,775	135 213
UEG 40/200 K 4⁽¹⁾	2,775	135 170
UEG 40/300-500	2,785	135 374
UEG 40/300-500 K 4⁽¹⁾	2,785	135 375

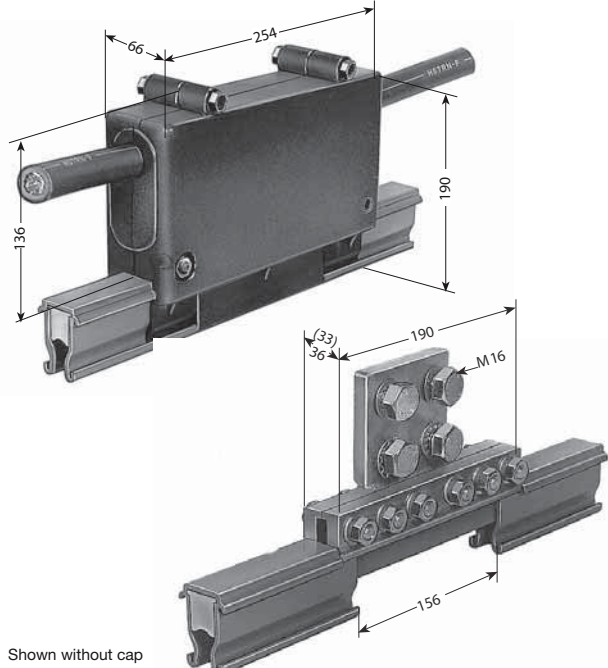

dimension in parenthesis for UEVG 40/200

for joint mounting

Type	Weight kg	Order- No.
UEVG 40/200	2,825	135 172
UEVG 40/200 K 4⁽¹⁾	2,825	135 174
UEVG 40/300-500	2,835	135 376
UEVG 40/300-500 K 4⁽¹⁾	2,835	135 377

Feed cables: 4 of max. 150 mm²

⁽¹⁾ Stainless steel hardware



ACCESSORIES FOR U 40

Transfer guide

Transfer guides are used for transfer or power-interrupting applications. Max. vertical and horizontal offset: ± 6 mm, max. air gap: 12 mm. Additional hangers have to be considered and have to be ordered separately.

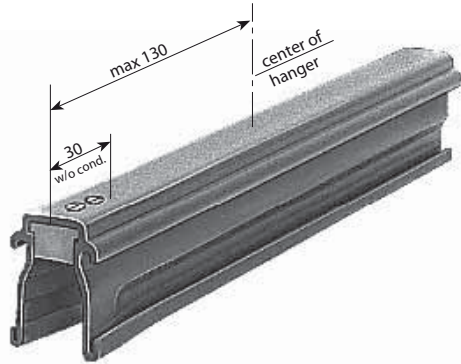

Type	Weight kg	Order- No.
UTI	0,014	134 910

UTI 40 are transfer buttons (bellmouth shaped conductor ends) with integrated isolating piece. They are factory assembled to layout plans.

For separate ordering indicate conductor length and size. The conductor rail has to be ordered separately.

Isolating sections

Type M: Factory assembled per system layout
 Type L: Loose, including two locking pins 4 x 8

Position of isolating sections per system layout. Use one extra hanger each side, max. 400 mm away for stability.

Rails & hangers to be ordered separately.

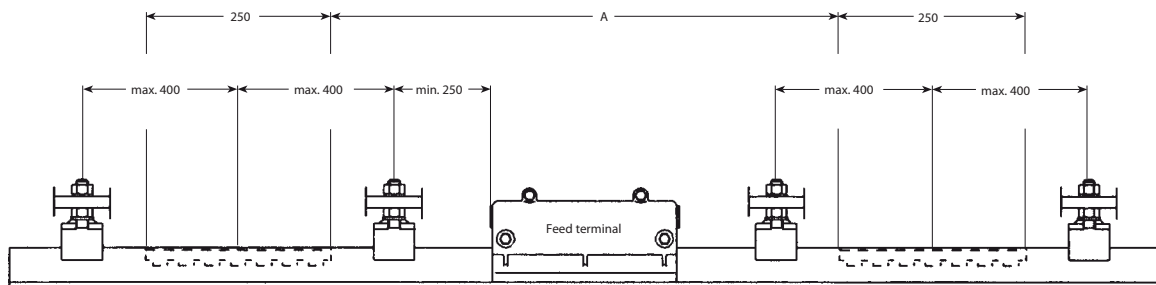
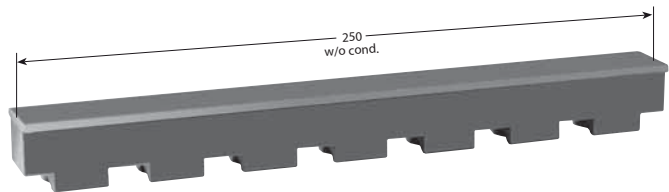

To avoid voltage by-pass by carbon brushes and to separate maintenance bays, control and main feed sections, double isolating sections are recommended.

Dim. A depends on type and number of current collectors and stopping distance of the crane.

Type	Weight kg	Order- No.
IT/U 40/200 C -M	0,104	135 176
IT/U 40/300 C -M	0,104	134 790
IT/U 40/300 CH -M	0,104	135 187
IT/U 40/400 C -M	0,104	134 800
IT/U 40 400 CH -M	0,104	135 188
IT/U 40/500 C -M	0,104	134 810
IT/U 40/500 CH -M	0,104	134 820
IT/U 40/500 CHH -M	0,104	135 378

Type	Weight kg	Order- No.
IT/U 40/200 C -L	0,104	134 210
IT/U 40/300 C -L	0,104	134 220
IT/U 40/300 CH -L	0,104	134 230
IT/U 40/400 C -L	0,104	134 250
IT/U 40 400 CH -L	0,104	134 260
IT/U 40/500 C -L	0,104	134 270
IT/U 40/500 CH -L	0,104	134 370
IT/U 40/500 CHH -L	0,104	134 380



Insulated hangers

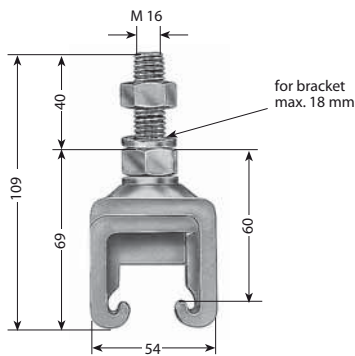

Type	Weight kg	Order- No.
UAM 40	0,285	135 040
UAM 40 K 4⁽¹⁾	0,285	134 610

Hangers

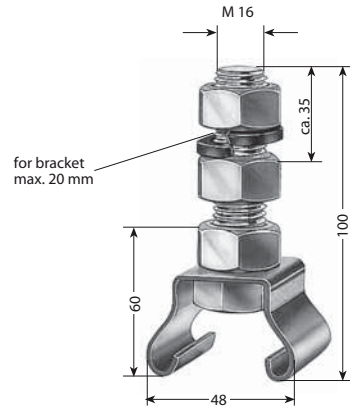

Type	Weight kg	Order- No.
UA 40	0,300	134 090
UA 40 K 4⁽¹⁾	0,300	134 400

Insulators

High voltage insulators are available

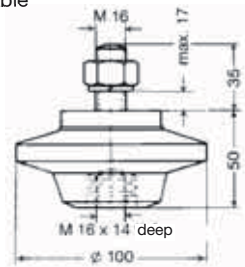

Type	Weight kg	Order- No.
GH 50-M 16	0,510	135 179
GH 50-M 16 K 4⁽¹⁾	0,510	135 380

Cantilever = 9000 N
Leakage distance = 80 mm

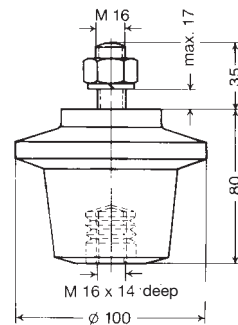

Type	Weight kg	Order- No.
GH 80-M 16	0,780	135 181
GH 80-M 16 K 4⁽¹⁾	0,780	135 382

Cantilever = 9500 N
Leakage distance = 120 mm

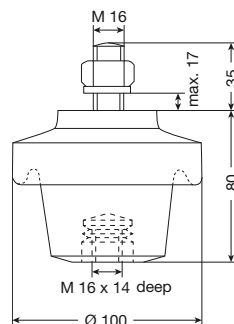

Cantilever = 9500 N
Leakage distance = 125 mm

Type	Weight kg	Order- No.
GHH 80-M 16	0,870	135 875
GHH 80-M 16 K 4⁽¹⁾	0,870	135 877

Rail holders

to go with insulators

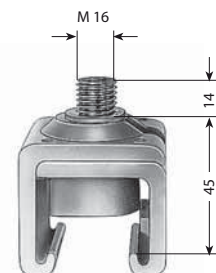
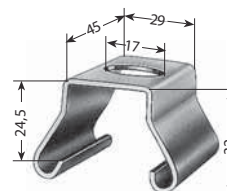

UAS
Supplied with bolt M 16 x 16
and spring washer

UAK
Supplied with washer

Type	Weight kg	Order- No.
UAS 40	0,140	134 100
UAS 40 K 4⁽¹⁾	0,140	134 550
UAK 40	0,170	135 183
UAK 40 K 4⁽¹⁾	0,170	135 185

⁽¹⁾ Stainless steel hardware



COLLECTORS FOR U 40

Current collectors

Use Type USTR for vertical Powerail installation.

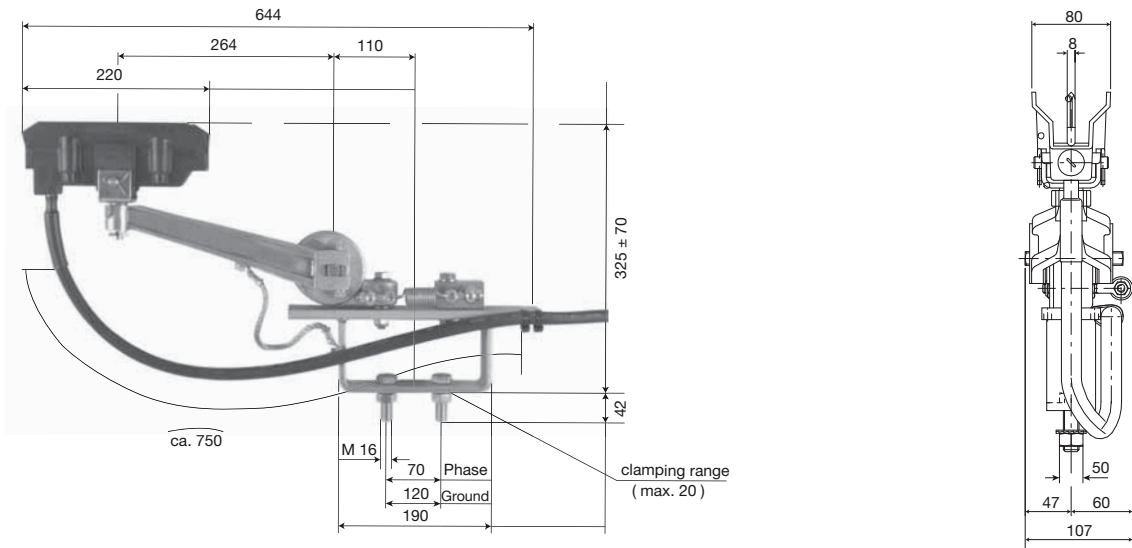

with 2 m connecting cable
 lift ± 70 mm
 swivel ± 80 mm
 contact pressure: approx. 50 – 70 N

Type	Am- pacity A	Connecting cable		Weight kg	Order- No.	
		mm ²	ø max/ mm		phase - black	ground yellow
UST 200	200	50	21	9,400	134 300	134 310
USTR 200	200	50	21	9,500	134 157	134 158

Double collector

Use Type UDSTR for vertical Powerail installatio

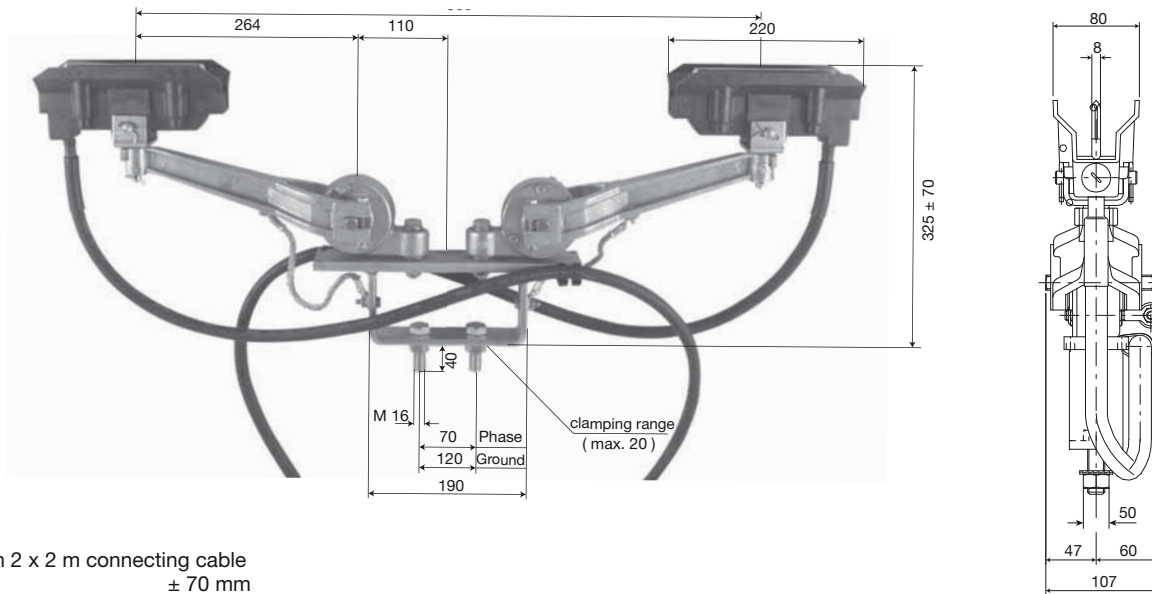

with 2 x 2 m connecting cable
 lift ± 70 mm
 swivel ± 80 mm
 contact pressure: approx. 50 – 70 N per brush

Type	Am- pacity A	Connecting cable		Weight kg	Order- No.	
		mm ²	ø max/ mm		phase - black	ground yellow
UDST 400	400	50	21	15,300	134 320	134 330
UDSTR 400	400	50	21	15,500	135 912	135 980



Spare parts for collectors of type UST 200, UDST 400, USTR 200 and UDSTR 400

Part.-No.	Description	Gewicht kg	Bestell-Nr.	
1	Brush KMU 200	0,410	135 207	
2	Brush holder	0,730	135 206	
3	Fork link with bolt	0,350	135 205	
4	Lever complete	0,750	135 204	
5	Spring housing complete for UST 200 and UDSTR 400	2,120	175 094	
6	Spring housing complete for USTR 200 and UDSTR 400	2,110	175 562	
7	Base plate compl.	phase	3,080	175 095
8	Base plate compl.	ground	3,080	175 096
9	Lower part for USTR 200	phase	5,950	175 554
10	Lower part for USTR 200	ground	5,950	175 555
11	Lower part for UDSTR 400	phase	7,610	175 556
12	Lower part for UDSTR 400	ground	7,610	175 557
13	Spring for USTR 200 and UDSTR 400	0,048	175 558	
14	Connecting cable RKA 50 mm ² , 2 m	phase	1,340	135 208
	Connecting cable RKA 50 mm ² , 2 m	ground	1,340	135 209
8	Connecting screw M 8x12 K4	0,010	170 871	

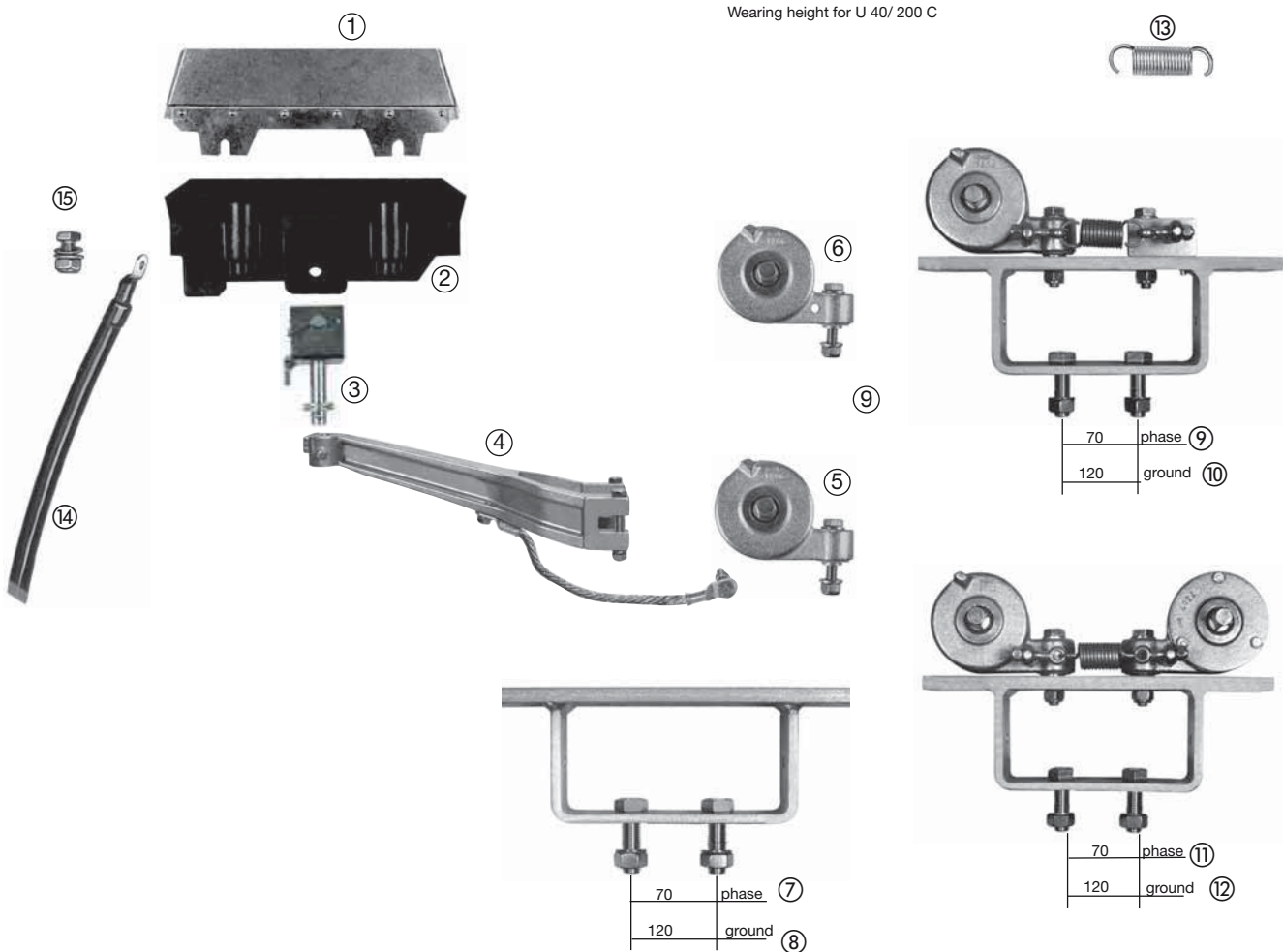



EXAMPLE FOR ORDERING U 40

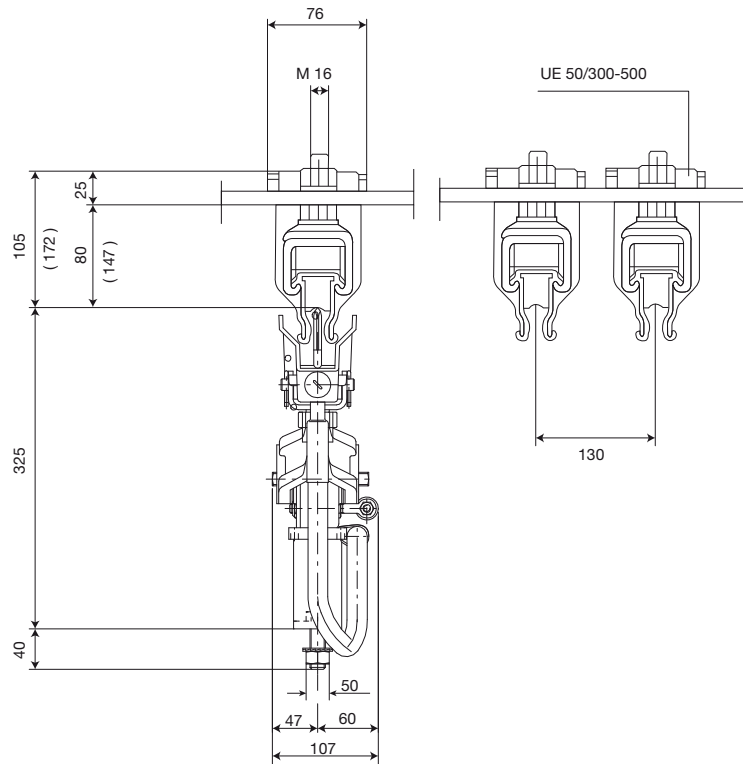

Dimensions in brackets include insulators type GH 80 with rail holder UAK 40.

Example for Ordering 250 m power supply system, 3 pole + ground, 1000 A

Qty.	Description	Type	Order- No.	
120	Insulated conductors, 6 m long	phase	U 40/500 C	134 366
3	Insulated conductors, 2 m long	phase	U 40/500 C	134 362
40	Insulated conductors, 6 m long	ground	U 40/300 C⁽¹⁾	136 126
1	Isolierte Stromschiene, 2 m long	ground	U 40/300 C⁽¹⁾	136 122
12	Expansion sections, 2 m long	phase	UDV 40/500 C	134 730
4	Expansion sections, 2 m long	ground	UDV 40/300 C⁽¹⁾	134 700
160	Rigid joints		UV 40/300-500	135 384
8	Feed terminals		UE 40/300-500	135 386
40	Locating clamps		USK 40 K 4	134 080
8	End caps		UK 40	134 060
504	Insulated hangers		UAM 40	135 040
6	Double collectors	phase	UDST 400	134 320
1	Double collectors	ground	UDST 400⁽¹⁾	134 330

Earthing spider system, 4 pole, for insulated conductors serves for earthing and short-circuiting the phase conductors with the ground conductor in the case of maintenance work.

The system consists of terminal clamps for the conductors and copper wire ropes and is designed for a short-circuit current of max.40 kA.

Earthing spider system cannot be used together with compact conductor arrangement.

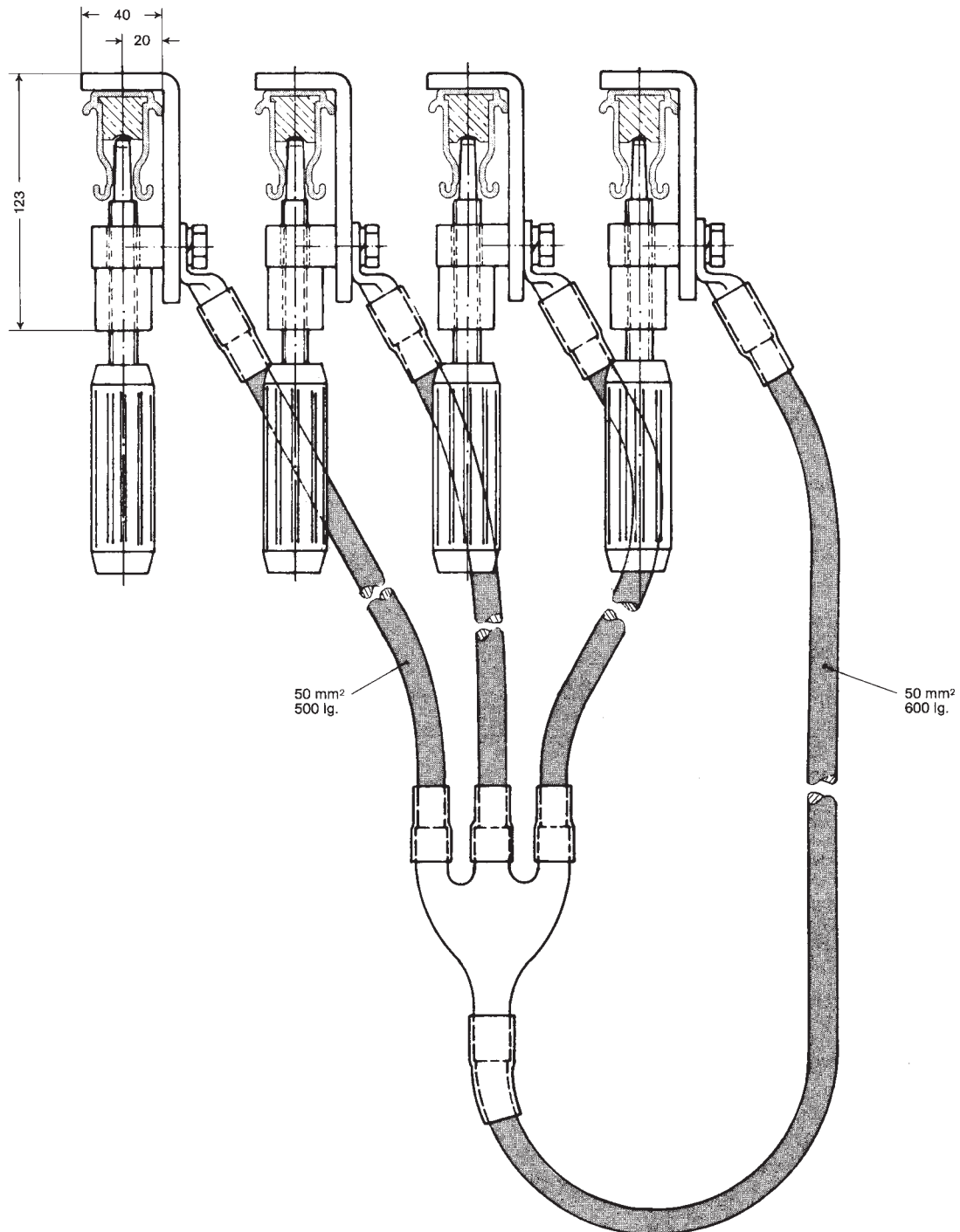

Type	for for conductor type	Copper section of wire rope	Order- No.
EUK	U 20, U 30, U 40	50 mm ²	130 035



QUESTIONNAIRE FOR INSULATED CONDUCTOR SYSTEMS⁽¹⁾

Fa. _____ Date: _____

Tel: _____ Fax: _____

E-Mail: _____ Internet: _____

1. No. of conductor systems: _____
2. Type of crane/machinery to be electrified: _____
3. Operating voltage: _____ Volts, Phases: _____, Frequency: _____ Hz
Three phase voltage: AC voltage: DC voltage:
4. Length of conductor systems: _____
5. Number of conductors: _____ (power lines: _____ control lines: _____ neutral (ground): _____)
6. Arrangement of conductors:
 Conductor rails suspending / Collectors standing
 Conductor rails resp. current collectors lateral
 Others: _____
7. Number of cranes or machines electrified from the one system: _____
8. Indoor: Outdoor:
9. Special site conditions (humidity, dust, chemical effects etc.):

10. Temperature conditions: _____ °C min. _____ °C max.
11. Expansion gaps of building: _____ pieces in max distance: _____ mm
12. Number and position of feeder points: _____
13. Number and position of isolating sections (e.g. for maintenance areas): _____
14. Mounting position envisaged: _____
(prints and sketches should be submitted whenever obtainable)
15. Travelling speed of machinery: _____
16. Ampere load of each crane/machine: _____
(Use table on page 45).
17. Max. voltage drop from feeder point to current collectors 3% or _____ % of voltage rating

Other important data: _____

Please submit prints or sketches for curved tracks, discontinuous etc.

QUESTIONNAIRE FOR INSULATED CONDUCTOR SYSTEMS⁽¹⁾



To our nearest local agency:

Date:

Motordata	Crane 1						Crane 2					
	Power kW	Nominal current			Starting current		Power kW	Nominal current			Starting current	
		A	$\cos\phi_N$	% ED	A	$\cos\phi_A$		A	$\cos\phi_N$	% ED	A	$\cos\phi_A$
Hoist motor												
Auxiliary hoist												
Long travel												
Cross travel												

Motordata	Crane 3						Crane 4					
	Power kW	Nominal current			Starting current		Power kW	Nominal current			Starting current	
		A	$\cos\phi_N$	% ED	A	$\cos\phi_A$		A	$\cos\phi_N$	% ED	A	$\cos\phi_A$
Hoist motor												
Auxiliary hoist												
Long travel												
Cross travel												

Mark motors * which can operate simultaneously.
 Mark motors which can start simultaneously.

Further remarks: e.g.

Signature: _____

⁽¹⁾ Please copy and fill in the questionnaire.



TYPICAL INSTALLATIONS

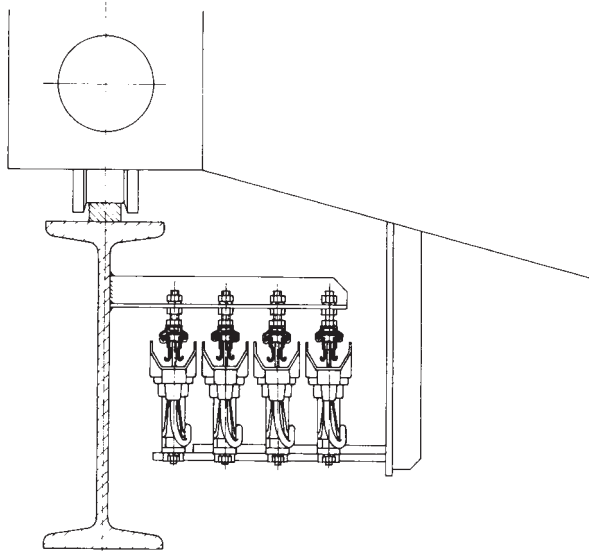

Suspended mounting of 4-pole system.

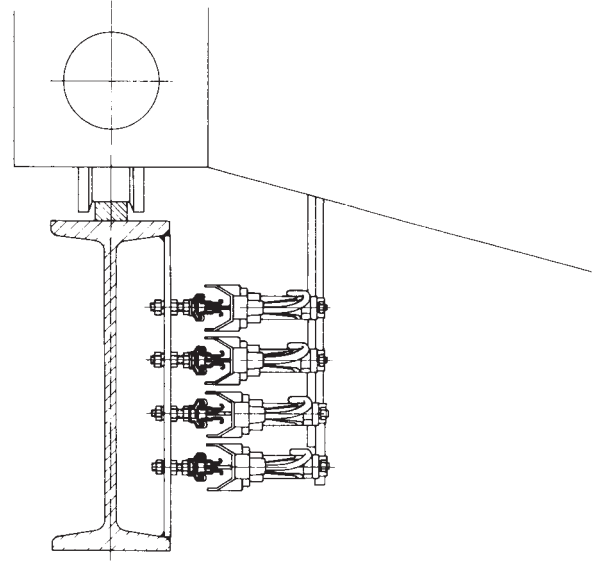

Lateral arrangement of the conductor rails.
Only in dry and dust free halls possible.
Lateral arrangement preferably with CH-profiles

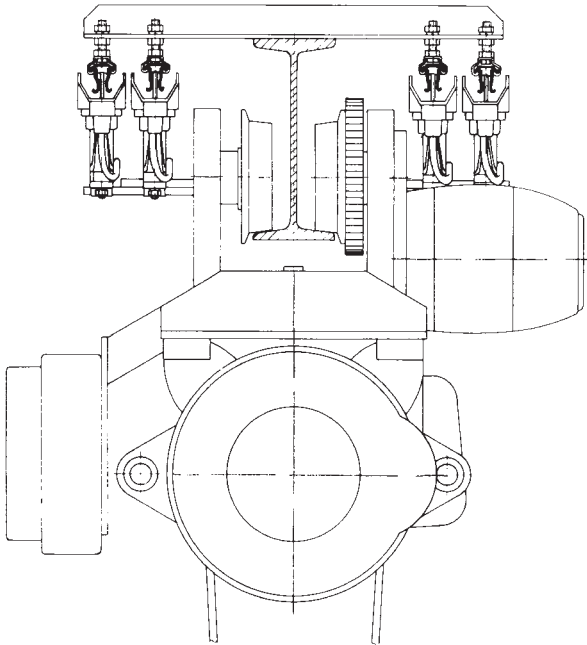

Equally balanced conductor arrangement
for monorail hoist.

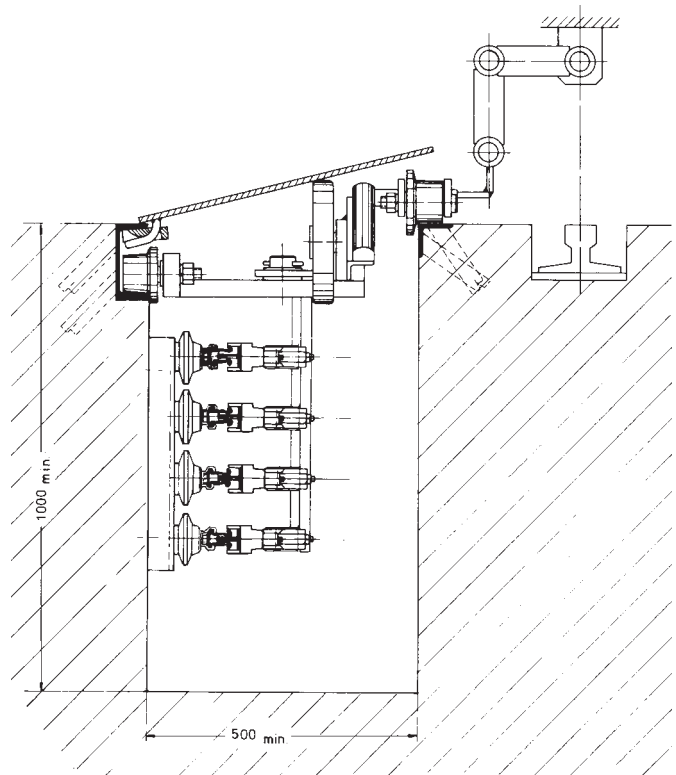

Insulated conductors U 30 in VAHLE trench system.



Products and Service

Catalog No.

1 Open conductor systems

Open conductor systems

1a

2 Insulated conductor systems

U 10

2a

FABA 100

2b

U 15 - U 25 - U 35

2c

U 20 - U 30 - U 40

2d

3 Compact conductor systems

VKS 10

3a

VKS - VKL

3b

4 Enclosed conductor systems

KBSL - KSL

4a

KBH

4b

MKLD - MKLF - MKLS

4c

LSV - LSVG

4d

5 Contactless power system

Contactless power system (CPS®)

5a

6 Data transmission

VAHLE Powercom®

6a

Slotted Microwave Guide (SMG)

6b

7 Positioning systems

VAHLE-APOS®

7a

8 Festoon systems and cables

Festoon systems for □- tracks

8a

Festoon systems for flat cables on I- tracks

8b

Festoon systems for round flat cables on I- tracks

8c

Festoon systems for ◇- tracks

8d

Cables

8e

9 Reels

Spring operated cable reels

9a

Motor powered cable reels

9b

10 Others

Battery charging systems

10a

Heavy enclosed conductor systems

10b

Tender

10c

Contact wire

10d

Assemblies/Commissioning

Spare parts/Maintenance service



Products and Service

Catalog No.

1 Open conductor systems	
Open conductor systems	1a
2 Insulated conductor systems	
U 10	2a
FABA 100	2b
U 15 - U 25 - U 35	2c
U 20 - U 30 - U 40	2d
3 Compact conductor systems	
VKS 10	3a
VKS - VKL	3b
4 Enclosed conductor systems	
KBSL - KSL	4a
KBH	4b
MKLD - MKLF - MKLS	4c
LSV - LSVG	4d
5 Contactless power system	
Contactless power system (CPS®)	5a
6 Data transmission	
VAHLE Powercom®	6a
Slotted Microwave Guide (SMG)	6b
7 Positioning systems	
VAHLE APOS®	7a
8 Festoon systems and cables	
Festoon systems for □- tracks	8a
Festoon systems for flat cables on I- tracks	8b
Festoon systems for round flat cables on I- tracks	8c
Festoon systems for ◇- tracks	8d
Cables	8e
9 Reels	
Spring operated cable reels	9a
Motor powered cable reels	9b
10 Others	
Battery charging systems	10a
Heavy enclosed conductor systems	10b
Tender	10c
Contact wire	10d

Assemblies/Commissioning

Spare parts/Maintenance service



Products and Service

Catalog No.

1 Open conductor systems	
Open conductor systems	1a
2 Insulated conductor systems	
U 10	2a
FABA 100	2b
U 15 - U 25 - U 35	2c
U 20 - U 30 - U 40	2d
3 Compact conductor systems	
VKS 10	3a
VKS - VKL	3b
4 Enclosed conductor systems	
KBSL - KSL	4a
KBH	4b
MKLD - MKLF - MKLS	4c
LSV - LSVG	4d
5 Contactless power system	
Contactless power system (CPS®)	5a
6 Data transmission	
VAHLE Powercom®	6a
Slotted Microwave Guide (SMG)	6b
7 Positioning systems	
VAHLE APOS®	7a
8 Festoon systems and cables	
Festoon systems for □- tracks	8a
Festoon systems for flat cables on I- tracks	8b
Festoon systems for round flat cables on I- tracks	8c
Festoon systems for ◇- tracks	8d
Cables	8e
9 Reels	
Spring operated cable reels	9a
Motor powered cable reels	9b
10 Others	
Battery charging systems	10a
Heavy enclosed conductor systems	10b
Tender	10c
Contact wire	10d

Assemblies/Commissioning

Spare parts/Maintenance service



POWERAIL LTD.

WORKING FOR THE FUTURE WITH

Powerail Ltd. High Road, Finchley, London, N12 8PT,

Phone 020 8446 0350/1246 • Fax 020 8446 7054

E-mail: enquiries@powerailtd.com

